

DŘEVOOBRÁBACIE NÁSTROJE

Zvyšujúca sa účinnosť strojového parku a logistických procesov zvyrazňuje potrebu spôsobilosti správneho výberu a nastavenia prevádzkových parametrov nástrojov s dopadom na kvalitu, efektívnosť a nákladovosť produkcie.

Naše silné skladové zázemie, dobre vybavená brúsiareň, kvalifikovaný personál a dlhodobá odborná orientácia zasadená do funkčného obchodného rozhrania sú Vám k dispozícii.



Ing. Boris Bršel

DREVOOBRÁBACIE NÁSTROJE



KOTÚČOVÉ FRÉZY

1



CNC UPINÁKY

7



OKENNÉ SYSTÉMY

1



STOPKOVÉ FRÉZY

8



FRÉZOVACIE NOŽE

2



OLEPOVANIE

9



PÍLOVÉ KOTÚČE

3



BRÚSENIE

10



PÍLOVÉ PÁSY

4



VZDUCH

11



VRTÁKY

5



PRÍSLUŠENSTVO

12



CNC FRÉZY

6



STROJE

13

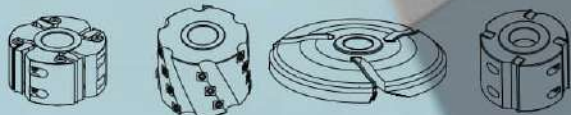
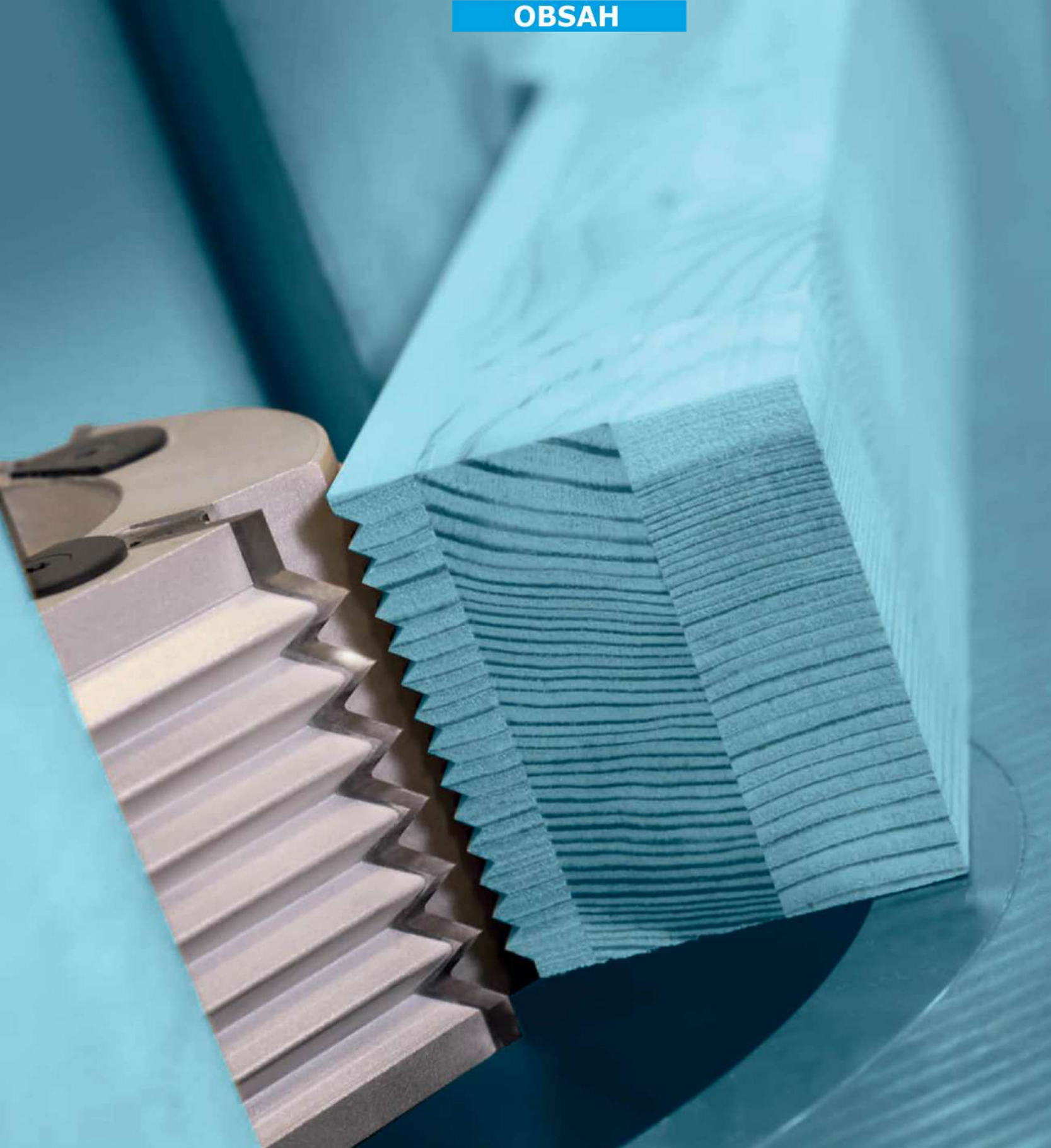

KOTÚČOVÉ FRÉZY



eshop.woodb.sk



STROJE

NÁSTROJE

NÁRADIE

KOVANIE

CHÉMIA

SPOJOVACÍ MATERIAL

DIELŇA

DOM-ZÁHRADA



Drážkovacie frézy

1.1

Špárovacie
a cinkovacie frézy

1.27



Čapovacie frézy

1.1

Frézy na pero-drážku,
obklady, podlahy

1.31

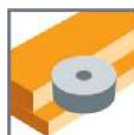

Falcovacie frézy

1.3



Frézy na dvierka

1.33

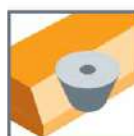

Uhlové frézy

1.4

Frézy na dvere
a zárubne

1.39



Zaobľovacie frézy

1.4

Frézy na okná a
vchodové dvere

1.52

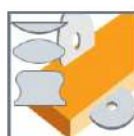
Lamely, lodičky, madlá,
multi, rohové

1.6

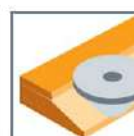

Výplňové frézy

1.35

Univerzálne nožové
hlavy

1.7



Príslušenstvo

1.47

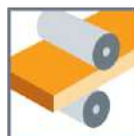

Hobľovacie valce

1.26

Sme špecialisti na
zákazkové frézy!

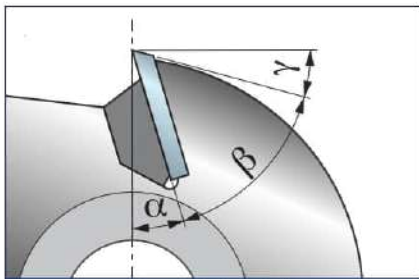

Geometria ostria

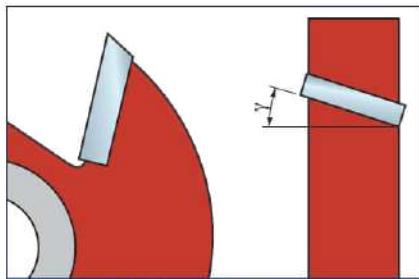

Uhol sklonu reznej hrany

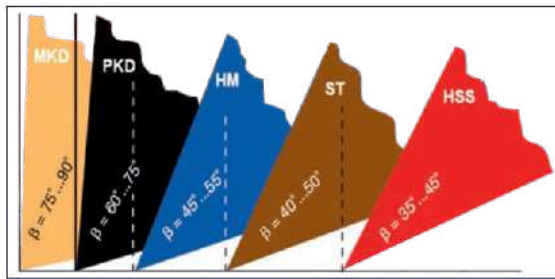

Závislosť rezného klinu na materiály ostria

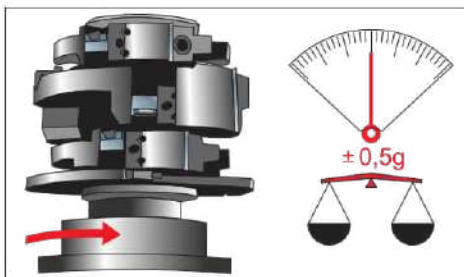

Presnosť vyvažovania nástroja

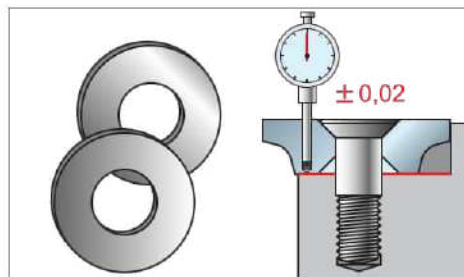

Presnosť uloženia elementov

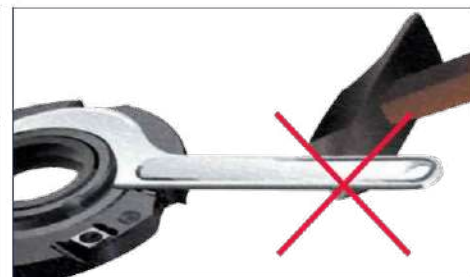

Správne upínanie

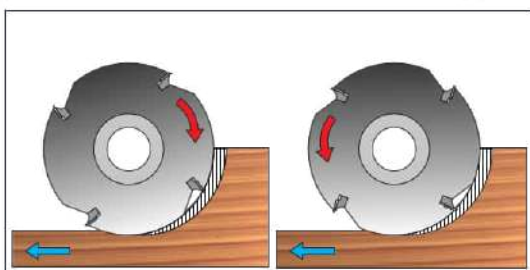

Posuv obrobní & otáčky nástroja

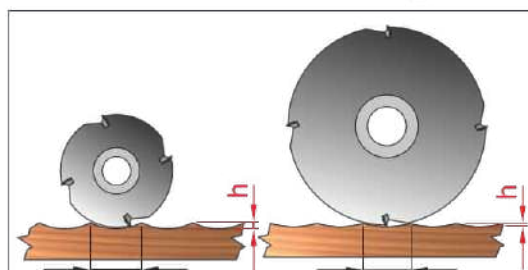

Vplyv priemeru nástroja na obrobnú plochu



Presnosť uloženia nožov

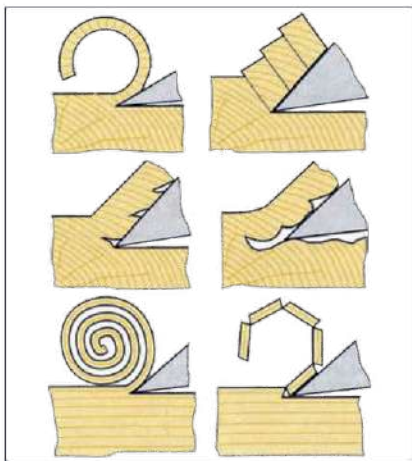

Formovanie triesky

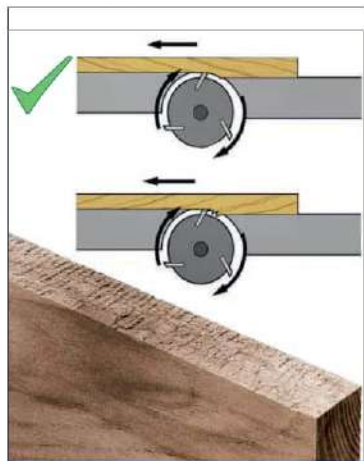

Smer vláknien

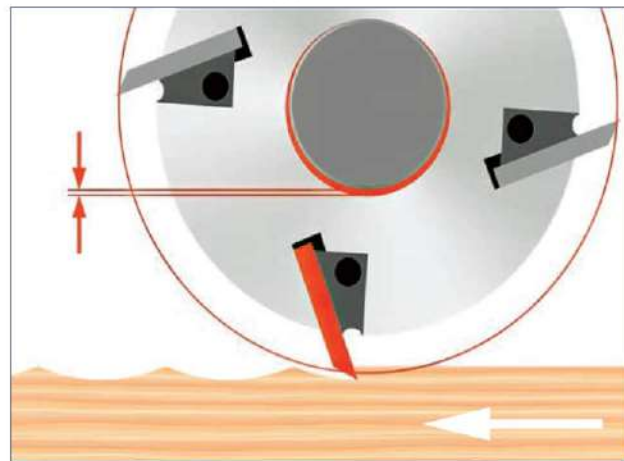

H7 / h7

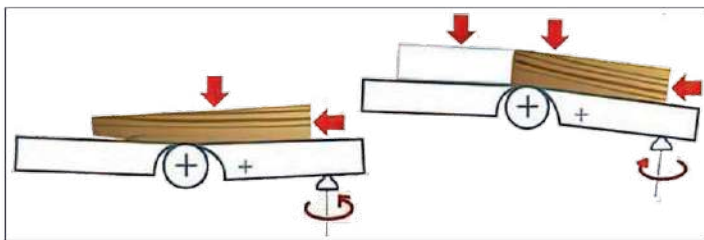

Zoradovanie stolov

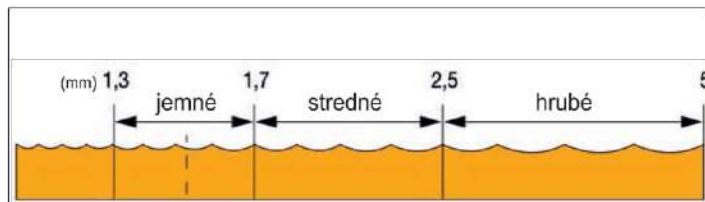

Kvalita povrchu

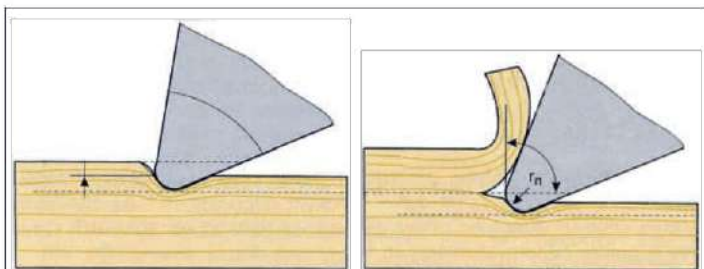

Podmienka odrezania triesky

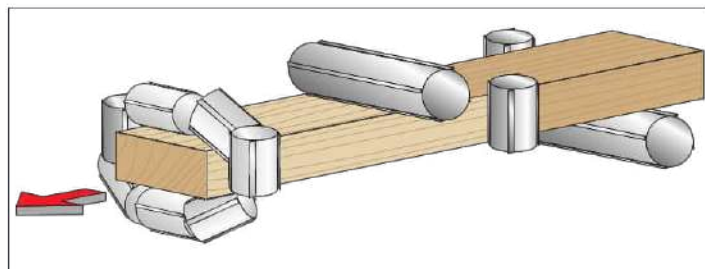

Štvorstranné obrábanie



22 50 10 DRAŽKOVACIE FRÉZY S ROVNÝMI ZUBAMI					HW	
ø D	B	ø d	Z	Nr	€	
125	4	30	4	111004	81,00	
125	5	30	4	111005	75,00	
125	6	30	4	111006	79,70	
125	8	30	4	111007	80,30	
125	10	30	4	111008	81,00	
125	12	30	4	111009	86,40	
160	4	30	4	111014	90,20	
ATYP 80-200	3-14	20-60				cena na vyžiadanie

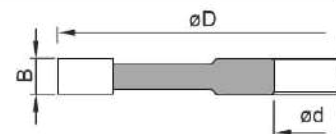

22 50 11 DRAŽKOVACIE FRÉZY S PREDREZÁVACÍMI ZUBAMI					HW	
ø D	B	ø d	Z	Nr	€	
125	4	30	4+2	111025	113,80	
125	5	30	4+2	111026	108,40	
125	6	30	4+2	111027	109,70	
125	8	30	4+2	111028	111,50	
125	10	30	4+2	111029	113,80	
125	12	30	4+2	111030	117,50	
125	16	30	4+2	111043	150,20	
125	20	30	4+2	111045	192,80	
160	5	30	4+2	111031	112,20	
160	6	30	4+2	111032	113,70	
160	8	30	4+2	111033	115,40	
160	10	30	4+2	111034	117,80	
160	12	30	4+2	111035	121,60	
160	14	30	4+2	111036	126,60	
ATYP 80-200	4-14	20-60				cena na vyžiadanie

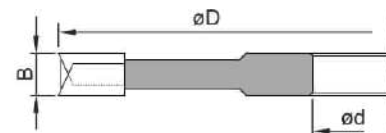

225392 FZ DRAŽKOVACIE PILOVÉ KOTUČE					HW	
ø D	B	ø d	Z	Nr	€	
MAN 125	2	30	8	2219212520	61,40	
MAN 125	2,5	30	8	2219212525	56,50	
MAN 125	3	30	8	2219212530	59,80	
MAN 125	4	30	8	2219212540	62,50	
MAN 125	5	30	8	2219212550	55,00	
MAN 125	6	30	8	2219212560	72,40	
MAN 125	8	30	8	2219212580	89,00	
MAN 125	10	30	8	22192125100	99,80	
150	2,0	30	12	2219215020	28,66	
150	2,5	30	12	2219215025	28,83	
150	3,0	30	12	2219215030	36,45	
150	3,5	30	12	2219215035	23,67	
150	4,0	30	12	2219215040	24,47	
150	5,0	30	12	2219215050	25,60	
150	6,0	30	12	2219215060	29,80	
180	4,0	30	16	2219218040	28,27	
180	5,0	30	16	2219218050	31,53	
180	6,0	30	16	2219218060	38,00	
200	4,0	30	32	2219220040	41,00	
200	5,0	30	32	2219220050	50,27	
ATYP 80-200	1,5-8	16-80				cena na vyžiadanie



Možnosť objednať aj s upínacími otvormi pre CNC stroje.



FI10D DRAŽKOVACIE FRÉZY S ROVNÝMI ZUBAMI					DIA	
ø D	B	ø d	Z	Nr	€	
125	3	30	12	235FI10D1253012A	192,00	
125	3	30	16	235FI10D1253016A	256,00	
125	4	30	12	235FI10D1254012A	258,00	
125	4	30	16	235FI10D1254016A	344,00	
125	5	30	12	235FI10D1255012A	330,00	
125	5	30	16	235FI10D1255016A	440,00	
ATYP 80-200	3-16	16-80				cena na vyžiadanie



Možnosť objednať aj s upínacími otvormi pre CNC stroje.



22 26 50 DRÁŽKOVACIE STAVITELNÉ FRÉZY						HW	
ø D	B	t	ø d	Z	Nr	€	
140	1,8-3,4	15	30	4+4	112SIR10TM01	181,40	
140	2,5-4,8	15	30	4+4	112SIR10TM02	192,00	
150	4-7,5	27	30	4+4	111125	169,17	
150	7,5-14,5	27	30	4+4	111126	178,33	
150	10-19	27	30	4+4	111127	218,80	

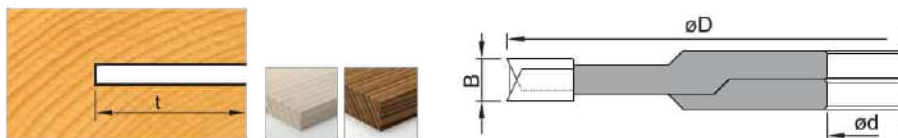

K-408 DRÁŽKOVACIE STAVITELNÉ ŽILETKOVÉ FRÉZY						HW	
ø D	B	t	ø d	Z	Nr	€	
160	4 - 7,5	32	30	8+4	530K408160430	199,00	
160	8 - 15,5	37	30	4+4	615K408160830	223,00	
160	12,5 - 22	53	30	4+4	615K408161230	223,00	
160	21 - 37	53	30	4+4	615K408162130	244,00	
160	31 - 57	53	30	4+4	615K408163130	266,00	

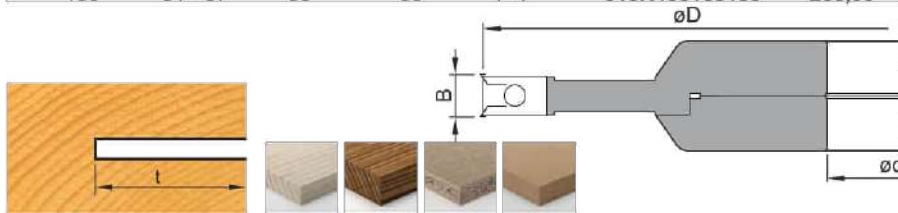

22 28 50 ČAPOVACIE FRÉZY						HW	
ø D	B	ø d	Z	Nr	€		
250	6	30	4	235285006	152,50		
250	8	30	4	235285008	163,50		
250	10	30	4	235285010	176,00		
250	12	30	4	235285012	191,00		
250	16	30	4	235285016	213,00		
250	20	30	4	235285020	234,00		
277	18	30	4	111141X	130,00		
ATYP 200~350 8~30					ø D	cena na vyžiadanie	

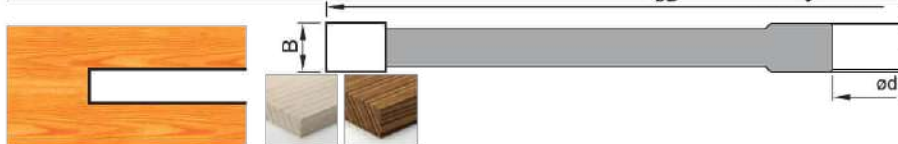

K432-1 ČAPOVACIE ŽILETKOVÉ FRÉZY						HW	
ø D	B	ø d	Z	Nr	€		
290	8	50	4	615K432010850	291,00		
290	10	50	4	615K432011050	308,00		
290	12	50	4	615K432011250	318,00		
290	14	50	4	615K432011450	333,00		
290	16	50	4	615K432011650	346,00		
290	18	50	4	615K432011850	358,00		
ATYP 200~350 8~30 30~60 4					ø D	cena na vyžiadanie	

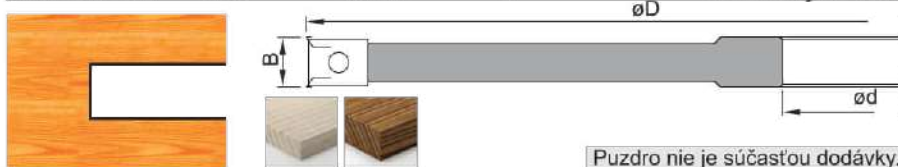

Puzdro nie je súčasťou dodávky.



96 PÍLOVÉ KOTUČE PRE KOLÍSAVÉ PUZDRO						HW	
ø D	t _{max}	B _{max}	ø d	Z	n	Nr	€
200	50	15	50	32	3800	22196KP0200	32,00
250	70	20	50	40	3000	22196KP0250	45,67
300	100	22	50	48	2500	22196KP0300	55,00
90	Kol.puzdro		30			221075	186,00

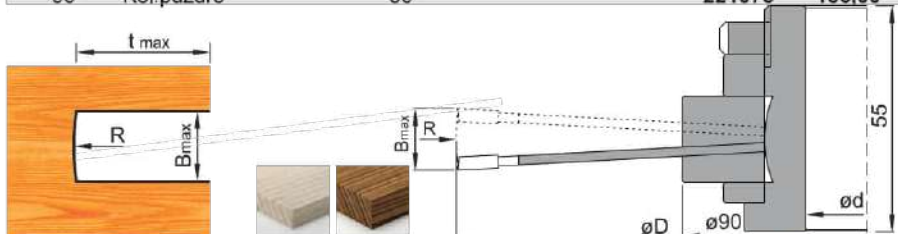

OBSAH



22 50 12					HW	
FALCOVACIE FRÉZY S PREDREZÁVACÍMI ZUBAMI						
$\varnothing D$	B	$\varnothing d$	Z	Nr	€	
125	20	30	4+4	235501220	198,00	
125	25	30	4+4	235501225	213,00	
125	30	30	4+4	235501230	234,00	
125	40	30	4+4	235501240	263,50	
125	50	30	4+4	235501250	282,00	
ATYP 100-200		10-80		cena na vyžiadanie		

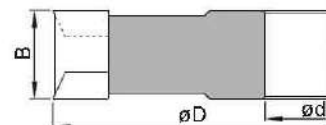

K419					HW	
FALCOVACIE FRÉZY S PREDREZÁVACÍMI ZUBAMI						
FRÉZY S ROVNÝMI ZUBAMI						
	$\varnothing D$	B	$\varnothing d$	Z	Nr	€
ALU	125	30	30	4+4	7002125030030A4	153,00
OCEL	125	31	30	4+4	615K418423130	172,00
OCEL	125	51	30	4+4	615K418425130	166,40

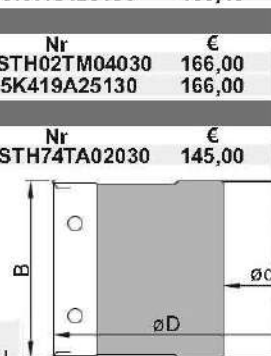

Nástroj s rovnými zubami odporúčame na laminované a dyhované materiály. Nástroj so striedavo šikmými zubami na masív a preglejku.



986					HW	
STAVITEĽNÉ ZAOBĽOVACIE FRÉZY						
	$\varnothing D$	B	B ₁	$\varnothing d$	Z	€
	125	60	8-60	40	4+2+2	53098660 355,00
	160	50	8-50	40	4+2+2	5301605040Z4R3 378,00

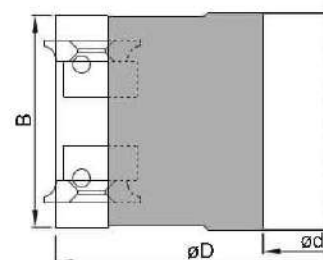
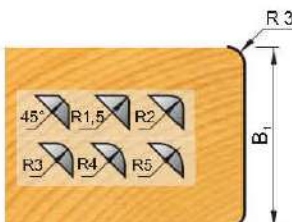

Výkonný nástroj osadený typizovanými žiletkami R3 pre 4-stranné frézovačky.



7062					HW	
ŠPIRÁLOVÉ OBVODOVÉ FRÉZY						
	$\varnothing D$	B	$\varnothing d$	Z	Nr	€
	80	76,5	30	12	112STH74TA01	149,00
	80	120	30	18	7022080120030A	214,00

KOPÍROVACIE LOŽISKO						
	$\varnothing D$	B	$\varnothing d$	Nr	€	
	80	16	30	301803016	17,50	

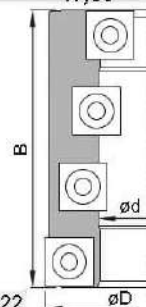

Nástroj pre frézovanie „okolo“ ložiska pre veľké úbery. Kombinujte s Linfixom str.12.22



22 50 18		ŠTVŔTKRUHOVÉ VYDUTÉ FRÉZY		HW				
$\varnothing D_1$	$\varnothing D$	R	B	$\varnothing d$	Z	Nr R	Nr L	€
98	108	3	10	30	4	111096	111096L	133,40
98	110	4	11	30	4	111097	111097L	132,00
98	112	5	12	30	4	111098	111098L	132,30
98	114	6	13	30	4	111099	111099L	148,30
98	118	8	15	30	4	111100	111100L	167,20
98	122	10	18	30	4	111101	111101L	192,20
98	126	12	21	30	4	111102	111102L	218,80
98	130	14	24	30	4	111103	111103L	208,20
98	134	16	27	30	4	111104	111104L	215,90
98	138	18	30	30	4	111105	111105L	219,70
98	142	20	32	30	4	111106	111106L	266,70
98	152	25	37	30	4	111107	111107L	305,60
98	162	30	42	30	4	111108	111108L	345,50

ATYP 60~200 1~50

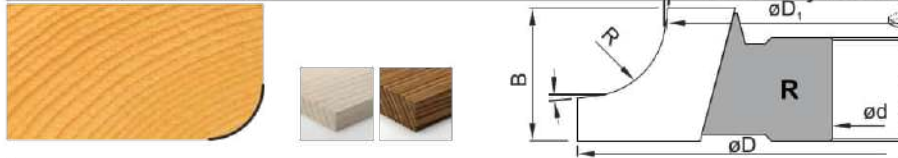

22 50 16		POLKRUHOVÉ VYDUTÉ FRÉZY		HW			
$\varnothing D$	B	R	$\varnothing d$	Z	Nr	€	
100	16	4	30	4	111075	144,00	
100	18	5	30	4	111076	145,00	
100	20	6	30	4	111077	153,00	
100	26	8	30	4	111078	180,70	
125	32	10	30	4	111079	210,80	
125	37	12	30	4	111080	225,50	
125	42	14	30	4	111081	247,50	
125	45	16	30	4	111082	266,00	
140	50	18	30	4	111083	293,00	
140	58	20	30	4	111084	311,00	

ATYP 60~200 1~50

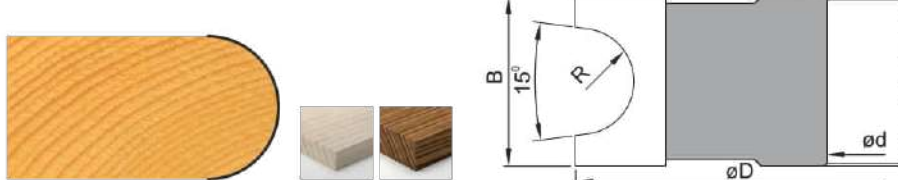

22 50 17		POLKRUHOVÉ VYPUKLÉ FRÉZY		HW			
$\varnothing D$	B	R	$\varnothing d$	Z	Nr	€	
100	6	3	30	4	111085	97,40	
100	8	4	30	4	111086	113,30	
100	10	5	30	4	111087	116,50	
100	12	6	30	4	111088	124,80	
100	16	8	30	4	111089	134,70	
125	20	10	30	4	111090	166,60	
125	24	12	30	4	111091	183,80	
125	28	14	30	4	111092	209,30	
125	32	16	30	4	111093	227,50	
140	36	18	30	4	111094	254,80	
140	40	20	30	4	111095	273,00	

ATYP 60~200 1~50

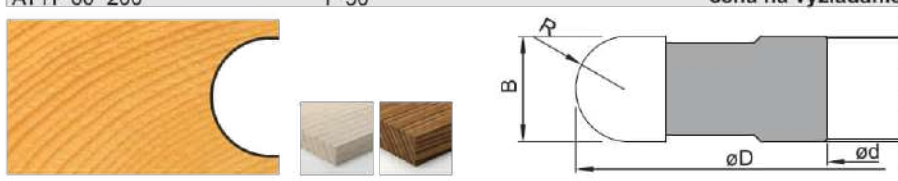

22 50 15		UHLOVÉ FRÉZY		HW			
$\varnothing D$	B	α	$\varnothing d$	Z	Nr R	Nr L	€
125	15	45°	30	4	111061	111061A	177,10
140	20	45°	30	4	111062	111062A	216,90
160	30	45°	30	4	111064	111064A	256,80

ATYP 60~200 10~80 30°~60°

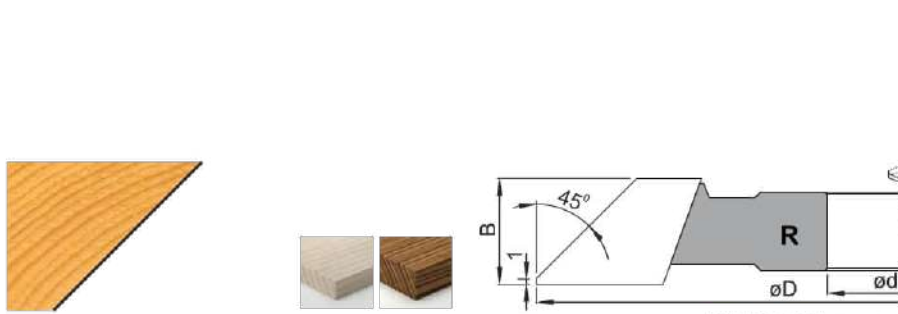



YH131 UHLOVÉ ŽILETKOVÉ FRÉZY		HW				
	ø D	B	ø d	Z	Nr	€
ALU	150	35	30	2	112SYH131AAM	151,80
OCEĽ	150	35	30	4	615A1550	260,00

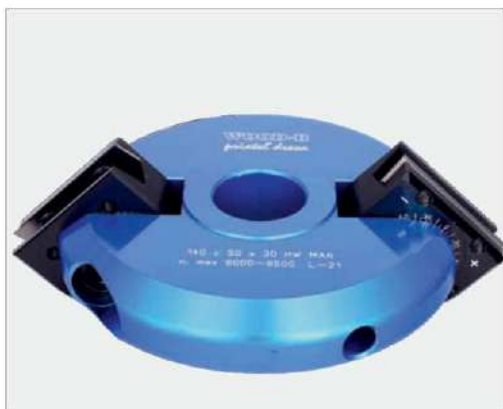
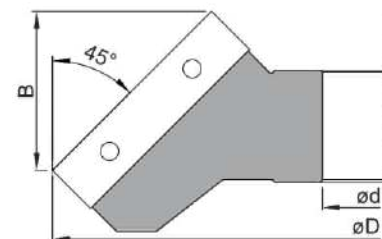

TH17 NASTAVITELNÉ UHLOVÉ FRÉZY LIGHT		HW				
	ø D	B	ø d	Z	Nr	€
ALU	140	50	30	2	112STH17TM41	270,00

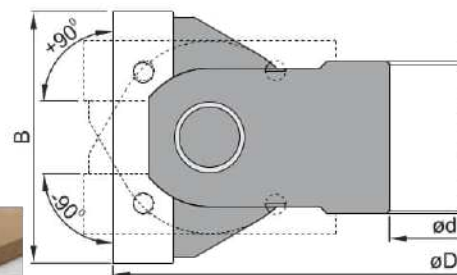

22920 MULTIPROFILOVÉ ZAOBĽOVACIE A UHLOVÉ FRÉZY		HW				
	ø D	B	ø d	Z	Nr	€
fréza	120	30	30	2	280TSP152E	142,50
žiletka						18,50
oporný nôž						17,60

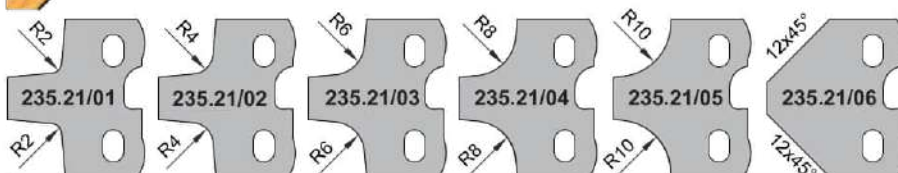
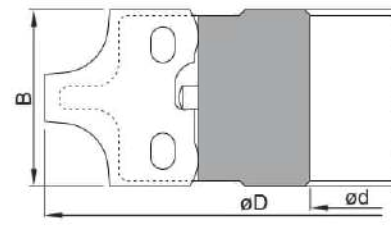

Teleso frézy je možné osadiť hociktorým z uvedených profilov. Možnosť výroby aj zákazkových profilových nôžov podľa strany 1.21



25513 PROFILOVACIE HRANOVÉ FRÉZY		HW					
	ø D	ø D1	B	ø d	Z	Nr	€
	145	125	50	50	2+2+2	301B2551302	697,15

priklady použitia

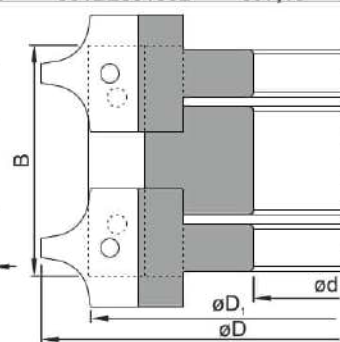
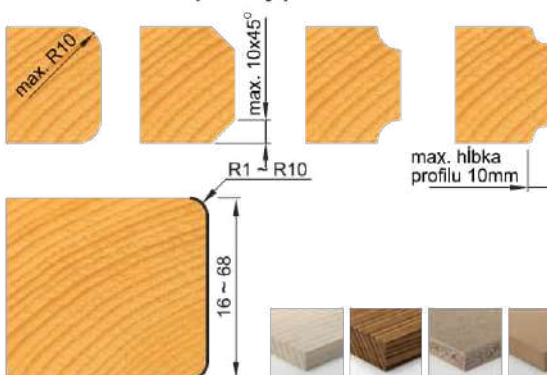

Sada zložená z 3 samostatných fréz. V základe sú osadené zaobľovacie profilové žiletky R=3. Nástroj je použiteľný pre hrúbky 16 až 68mm.



FI02M LAMELOVACIE FRÉZY				HW	
$\varnothing D$	B	$\varnothing d$	Z	Nr	€
100	3,97	22	6	280FI02MBX3P	26,80



06 LAMELOVACIE FRÉZY - ŽILETKOVÉ				HW	
$\varnothing D$	B	$\varnothing d$	Z	Nr	€
100	3,97	22	4+4	235T109M10004AA	133,60



FF09D LAMELOVACIE FRÉZY - DIAMANTOVÉ				DIA	
$\varnothing D$	B	$\varnothing d$	Z	Nr	€
100	3,97	22	6	235FF09D100006A	138,60



FF08D FRÉZY NA SPOJ CLAMEX				DIA	
$\varnothing D$	B	$\varnothing d$	Z	Nr	€
100,4	7	22	3	235TFF08D1002203	150,20

Diamantový nástroj na spoj typu Clamex. Nástroj použiteľný pre Lamelo aj cnc unášač.



040 LODIČKOVACIE FRÉZY				HW	
$\varnothing D$	B	$\varnothing d$	Z	Nr	€
100	8	22	4	111B	89,00



22 5820 UNIVERZÁLNE FLURY HLAVY

$\varnothing D$	B	Z	$\varnothing d$	Nr	€
100	50	2	30	225X	106,00
120	50	2	30	225Y	107,00
120	50	4	30	225YZ4	125,00

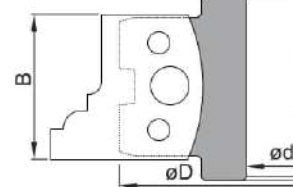

UPÍNACIE KLINY PRE FLURY HLAVY

	Nr	€
KLIN MAN, pre nôž hrúbky 4mm	111KD175	19,50
KLIN MEC, pre nôž hrúbky 4mm	111KD176	19,50
KLIN MEC, pre nôž hrúbky 5,5mm	111KD229	19,50



Zámenou upínacieho klinu možno do hlavy osadiť nože hrúbky 4 alebo 5,5mm pre MAN - MEC.



03.160 VÝPLŇOVÉ FLURY HLAVY

$\varnothing D$	B	Z	Nr	€
160	48	2	7003160048030A	210,00

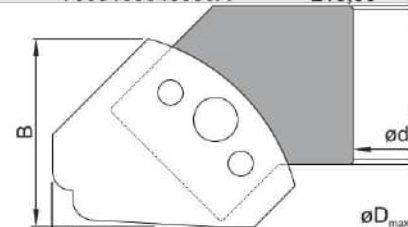

Nástroj je použiteľný pre vrchné i spodné branie.



FLURY 40x4 ZÁKAZKOVÝ PROFILOVÝ NOŽ

SP, HS

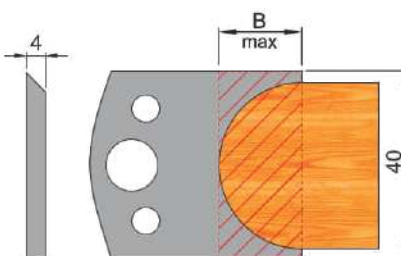

	B	€
nôž HS	17,5	36,25
obmedzovač SP	17,5	22,90
nôž HS	21,5	37,58
obmedzovač HS	21,5	34,92

Cena vyprofilovaného noža



Cena výbrusu nie je závislá na zložitosti profilu.

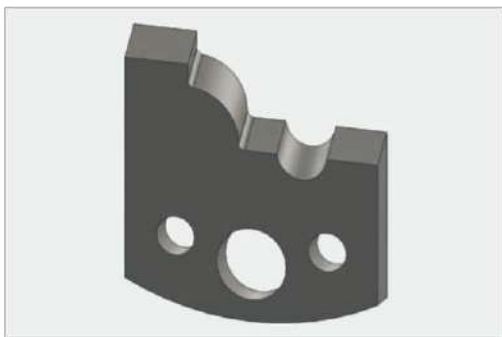

FLURY 50x4 ZÁKAZKOVÝ PROFILOVÝ NOŽ

SP, HS

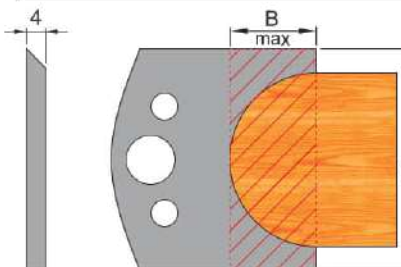

	B	€
nôž HS	17,5	42,46
obmedzovač SP	17,5	27,50
nôž HS	21,5	43,98
obmedzovač HS	21,5	40,60

Cena vyprofilovaného noža



Cena výbrusu nie je závislá na zložitosti profilu.

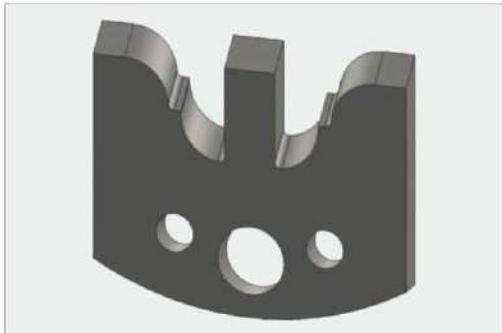

FLURY 50x5,5 ZÁKAZKOVÝ PROFILOVÝ NOŽ

SP, HS

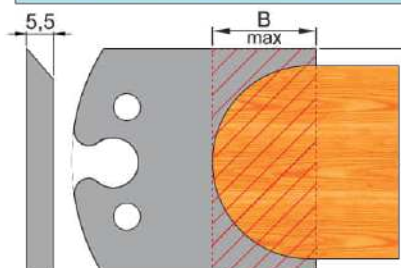

materiál	B	€
nôž SP (mäkké drevo)	24,5	30,44
nôž HS (tvrdé drevo)	24,5	59,00

Cena vyprofilovaného noža



Cena výbrusu nie je závislá na zložitosti profilu. Vyžaduje sa klin MEC 5,5.





		Nr	€
A	profilový nôž	22500A~225100A	5,95 /ks
B	obmedzovač triesky	22500B~225100B	5,20 /ks

Štandardné profilové nože vyrobené z nástrojovej ocele. Nevhodné na obrábanie tvrdých drevnín a MDF. Výrobná nepresnosť odpovedajúca hobby určeniu.

22500A/B

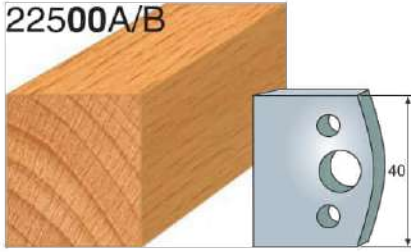

22501A/B

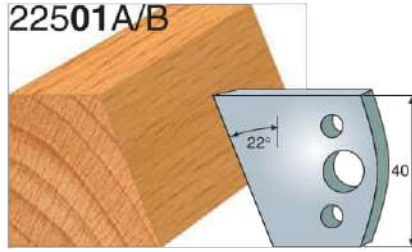

22502A/B

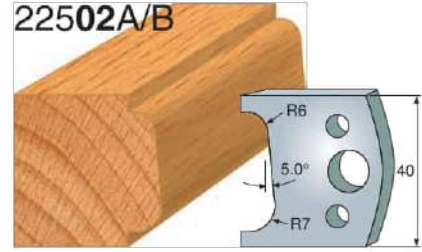

22503A/B

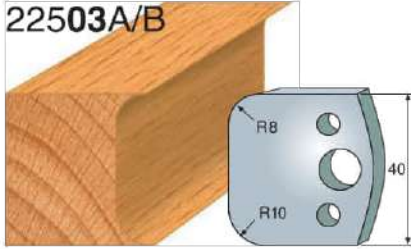

22504A/B

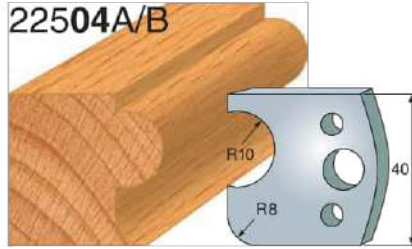

22505A/B

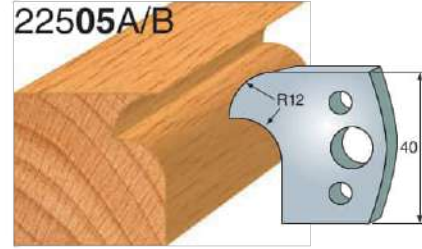

22506A/B

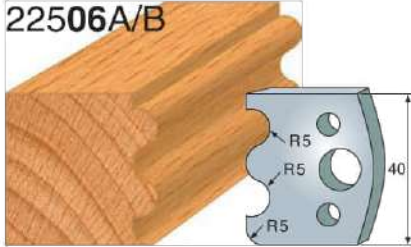

22507A/B

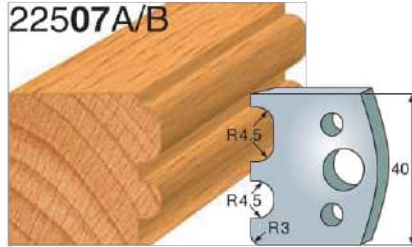

22508A/B

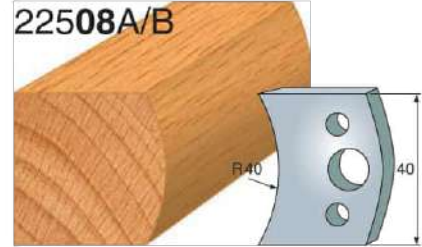

22509A/B

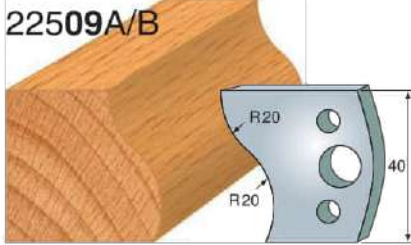

22510A/B

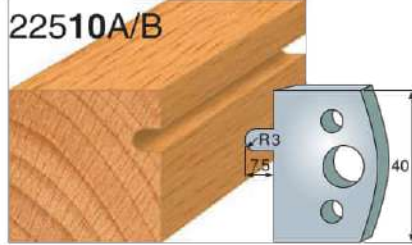

22511A/B

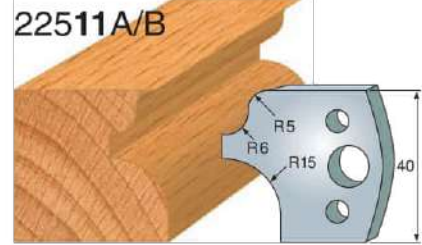

22512A/B

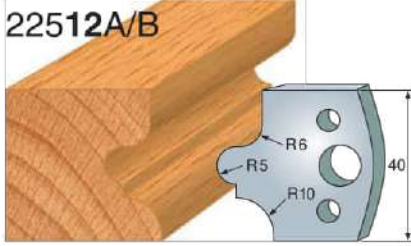

22513A/B

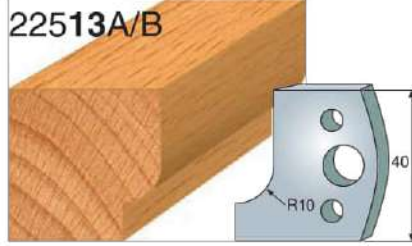

22514A/B

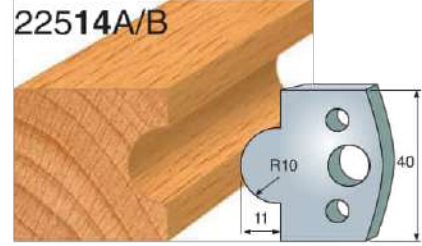

22515A/B

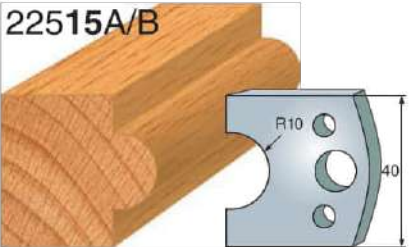

22516A/B

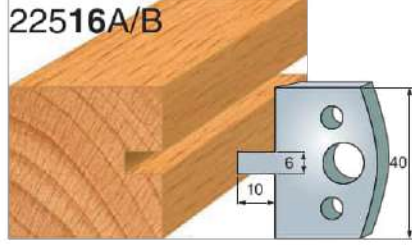

22517A/B

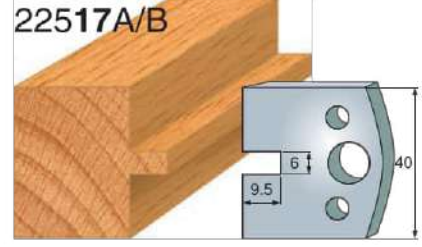

22518A/B

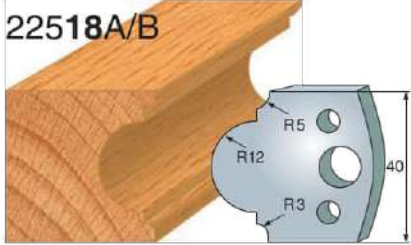

22519A/B

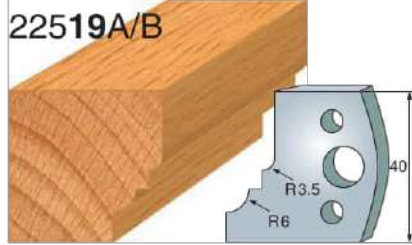

22520A/B

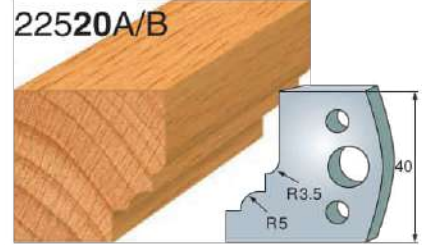

22521A/B

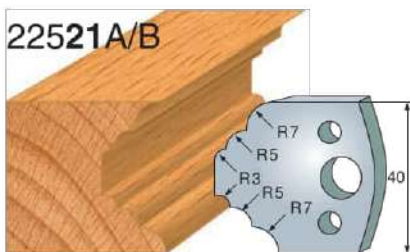

22522A/B

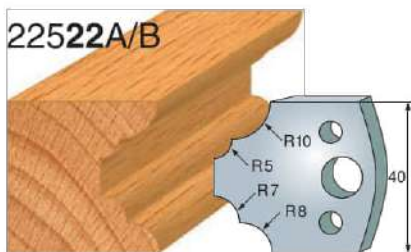

22523A/B

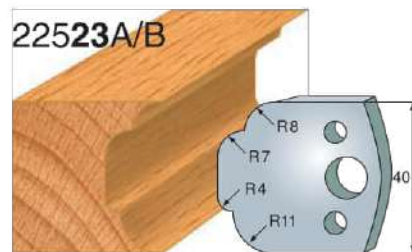

22524A/B

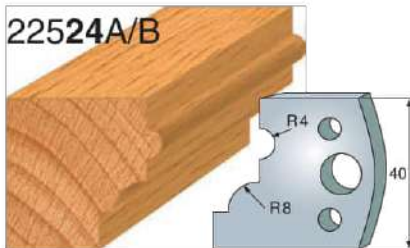

22525A/B

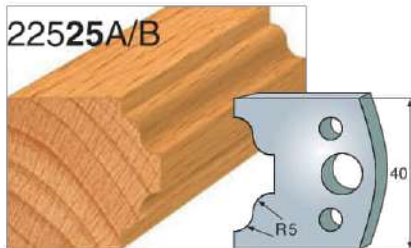

22526A/B

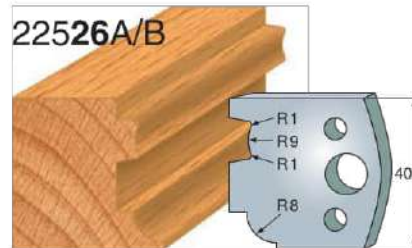

22527A/B

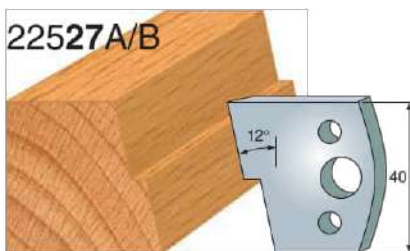

22528A/B

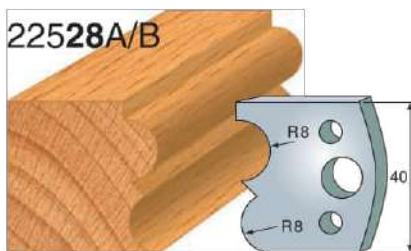

22529A/B

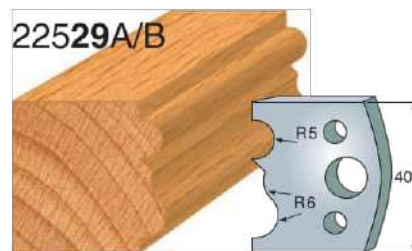

22530A/B

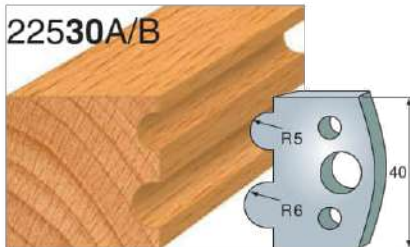

22531A/B

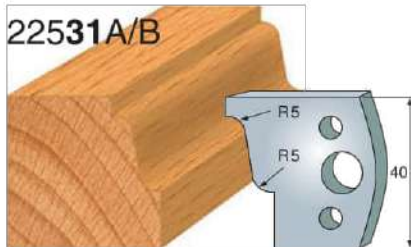

22532A/B

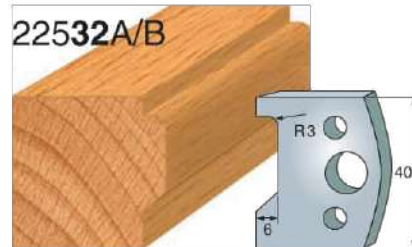

22533A/B

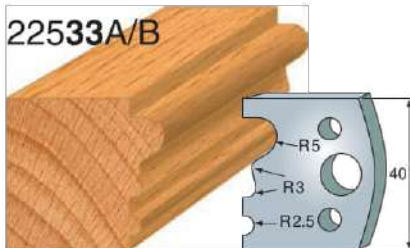

22534A/B

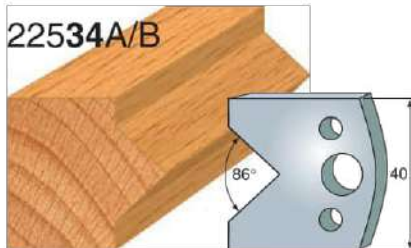

22535A/B

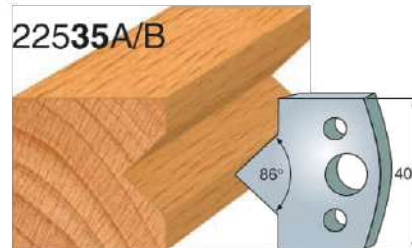

22536A/B

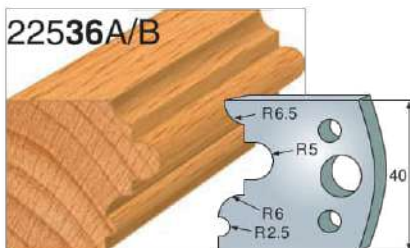

22537A/B

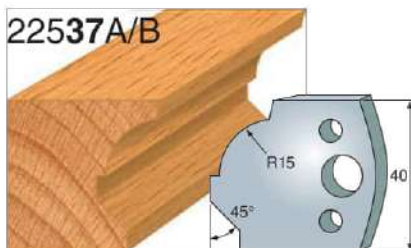

22538A/B

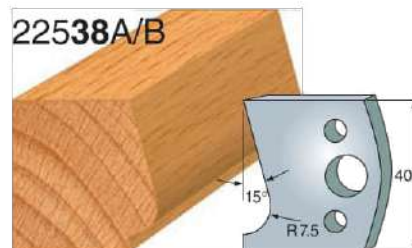

22539A/B

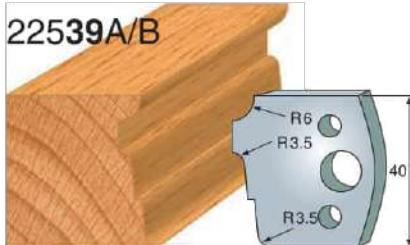

22540A/B

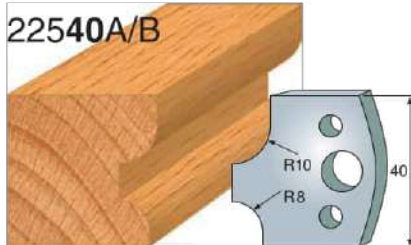

22541A/B

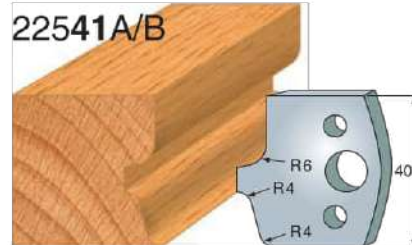

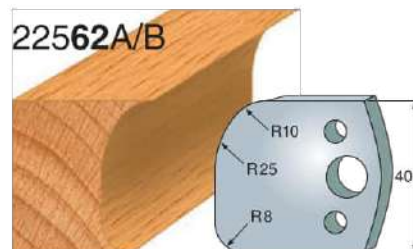
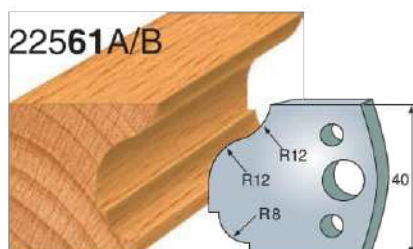
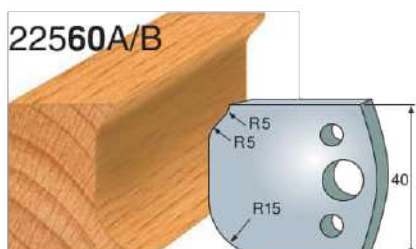
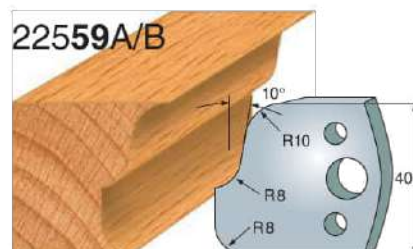
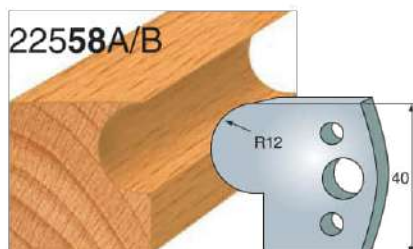
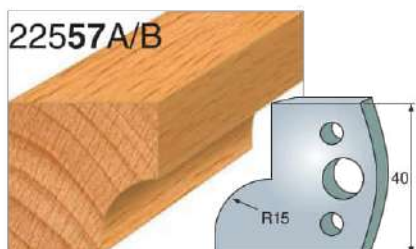
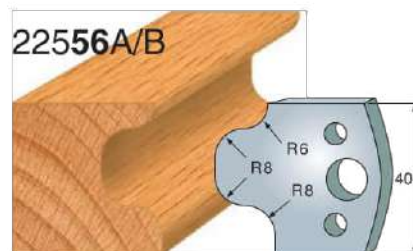
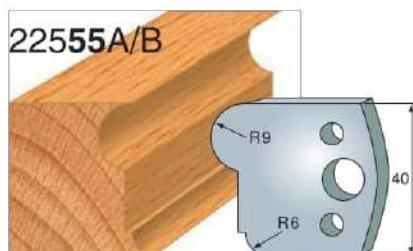
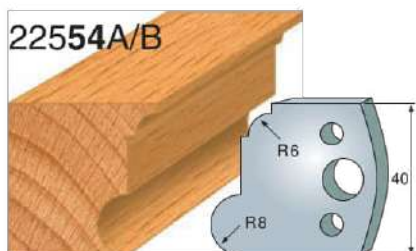
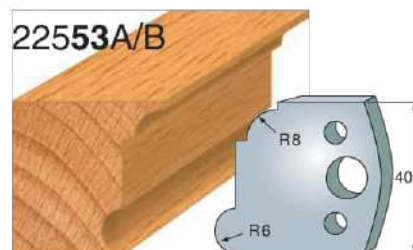
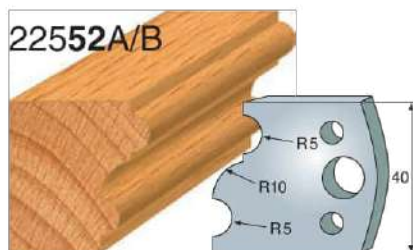
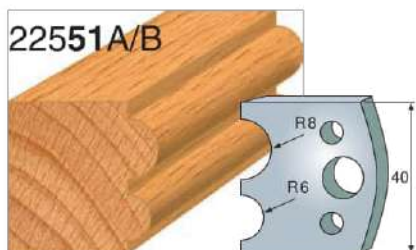
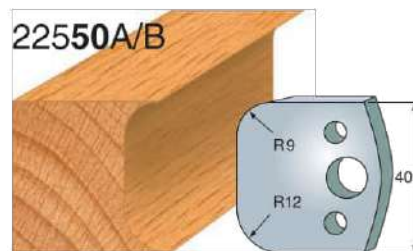
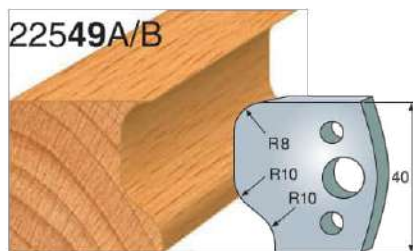
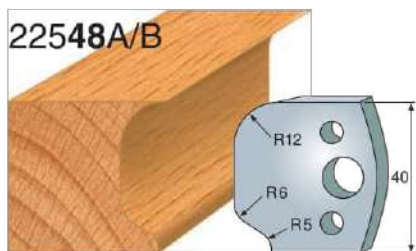
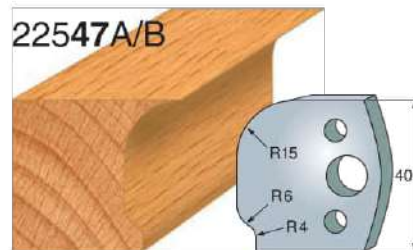
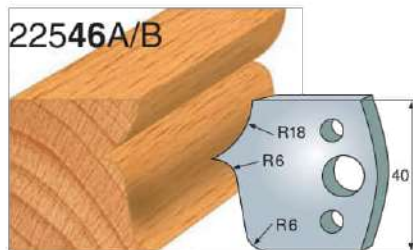
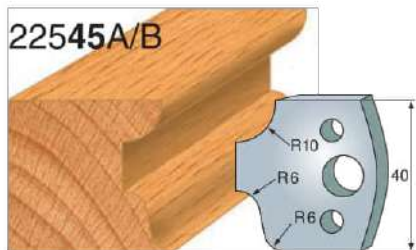
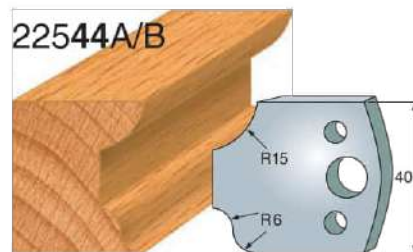
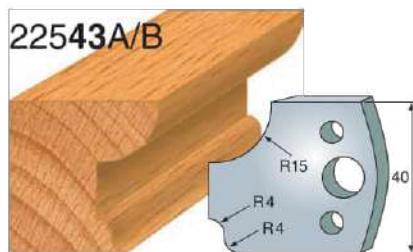
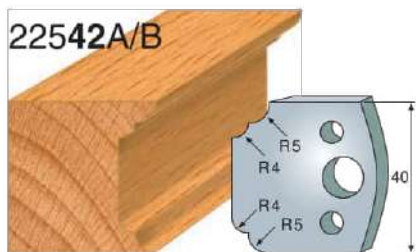

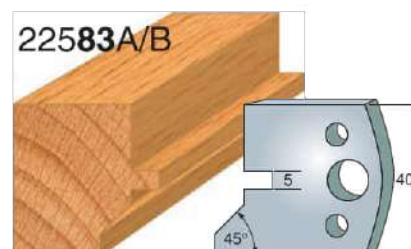
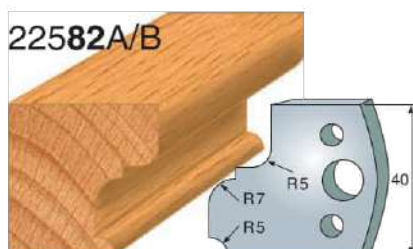
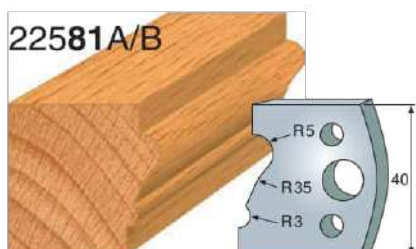
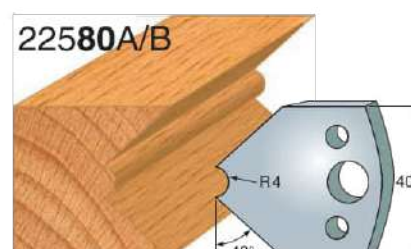
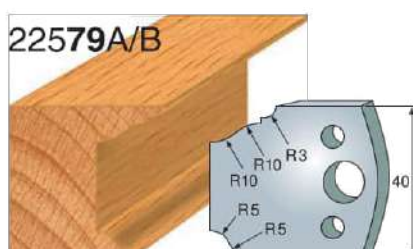
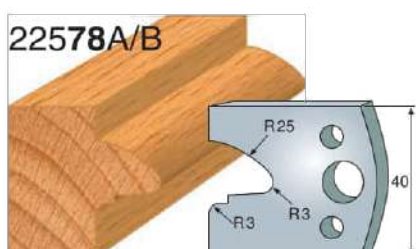
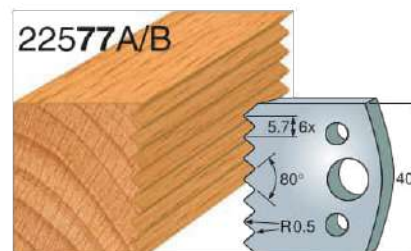
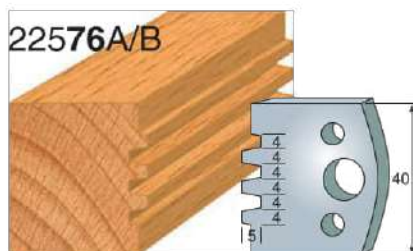
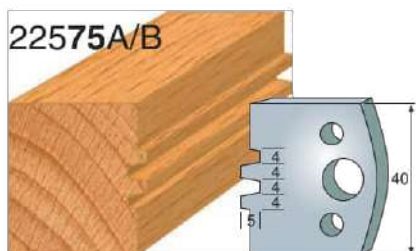
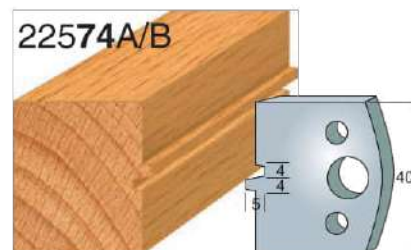
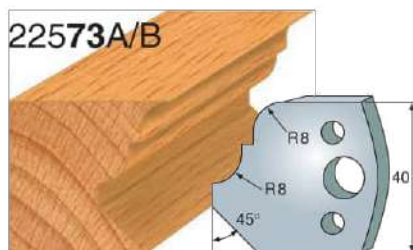
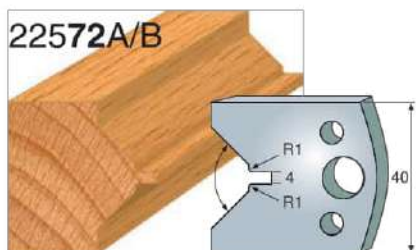
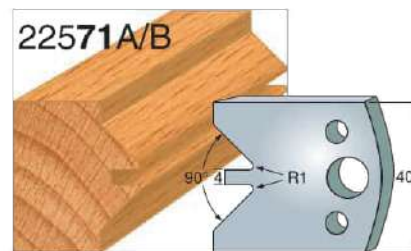
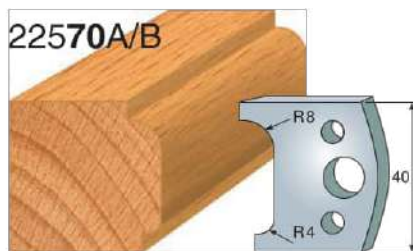
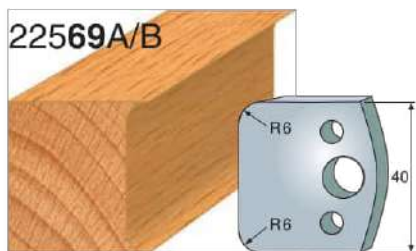
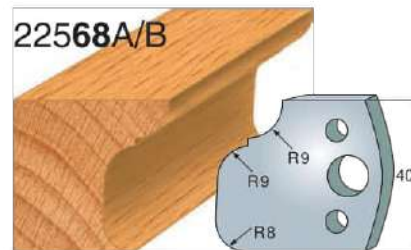
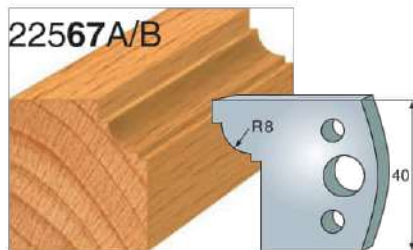
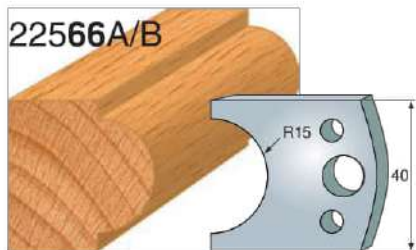
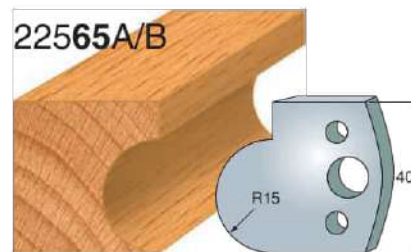
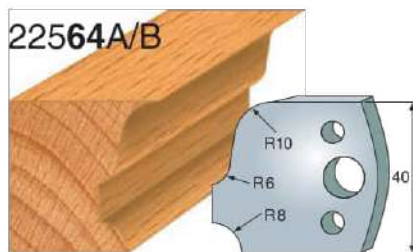
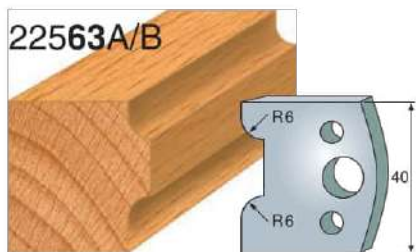

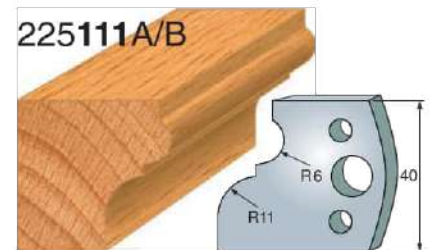
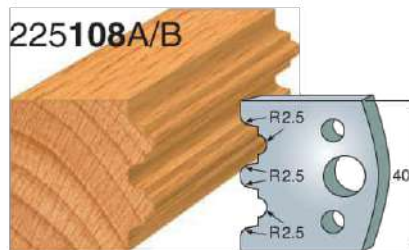
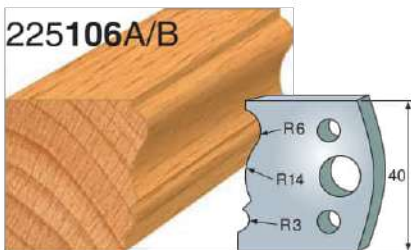
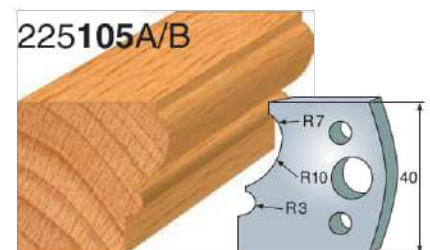
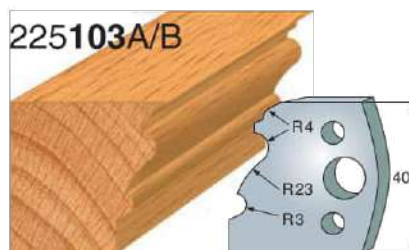
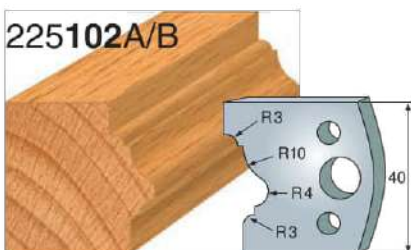
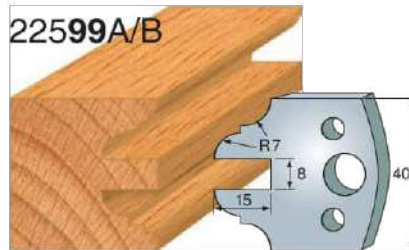
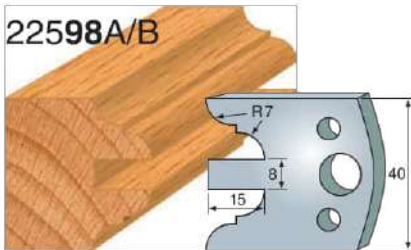
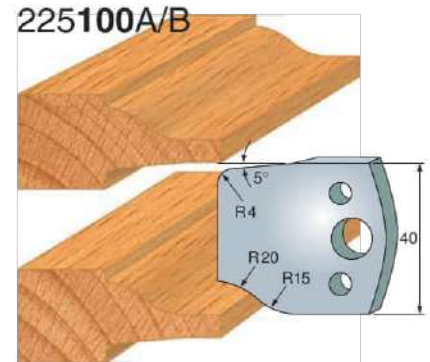
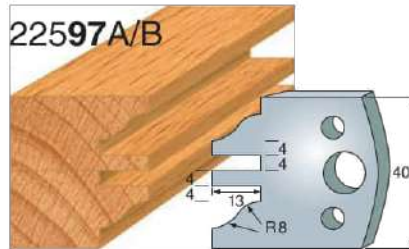
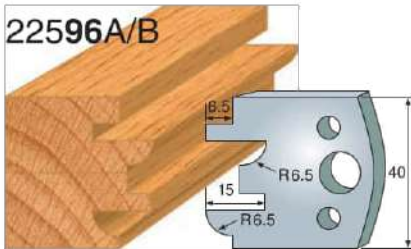
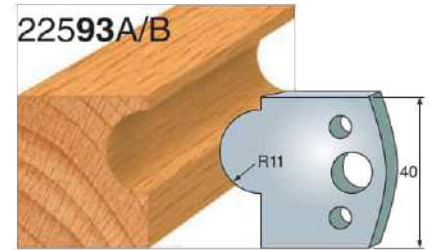
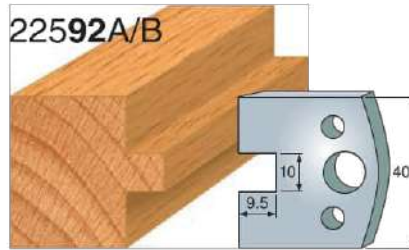
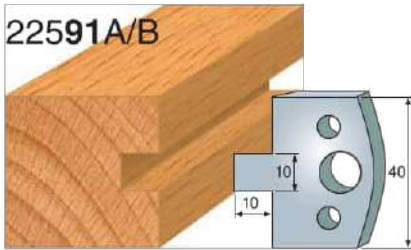
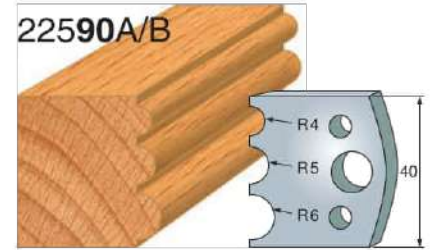
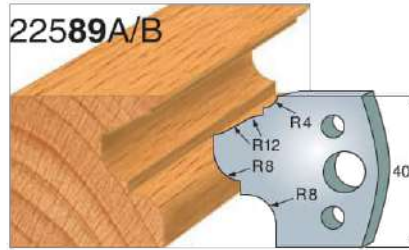
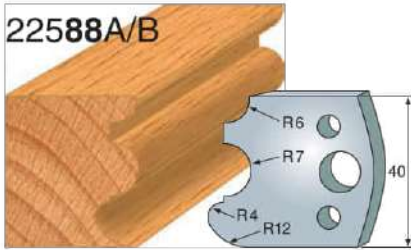
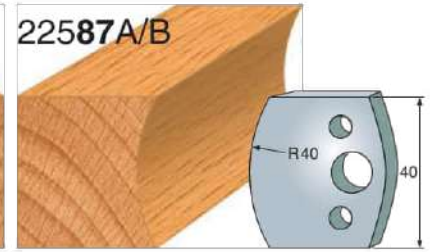
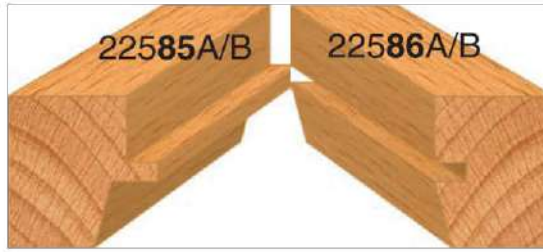
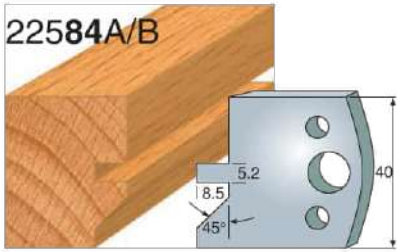

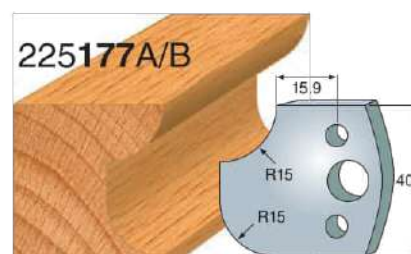
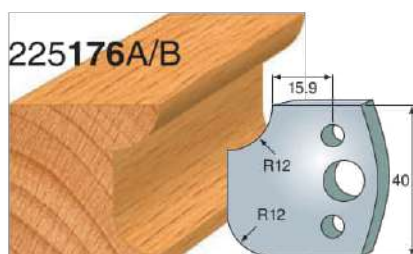
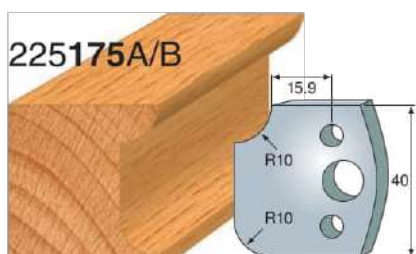
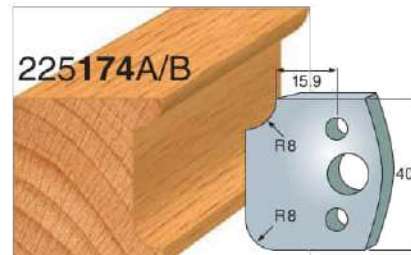
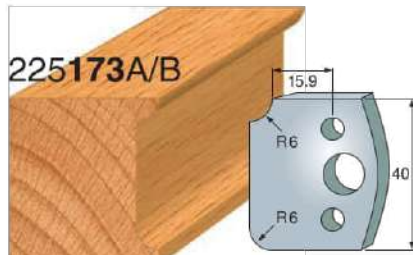
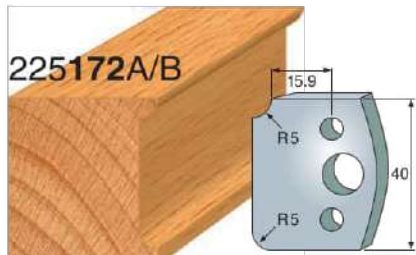
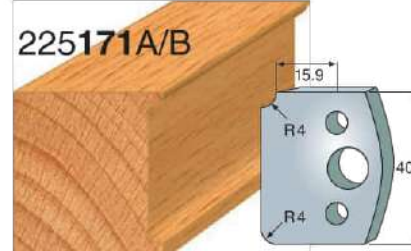
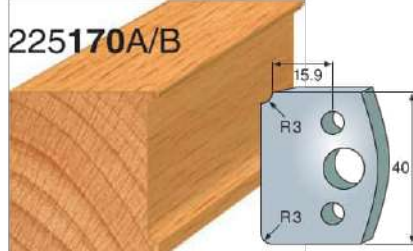
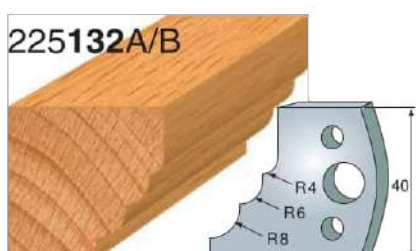
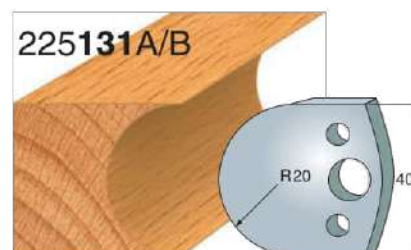
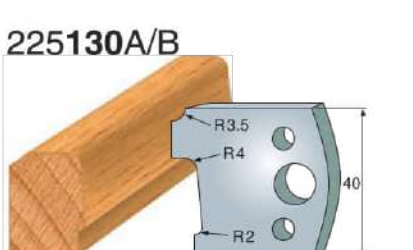
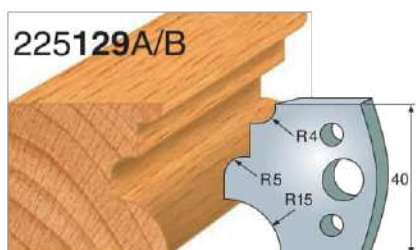
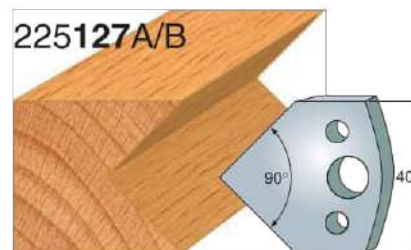
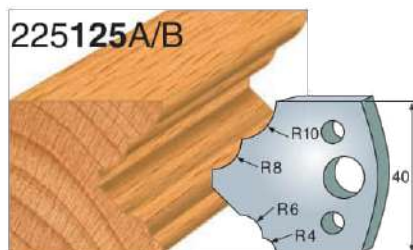
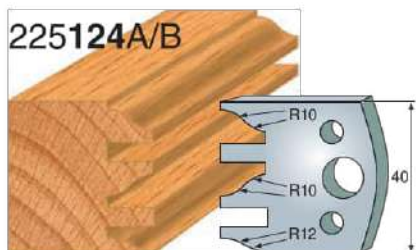
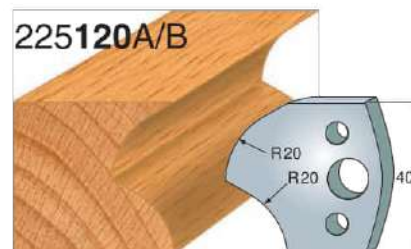
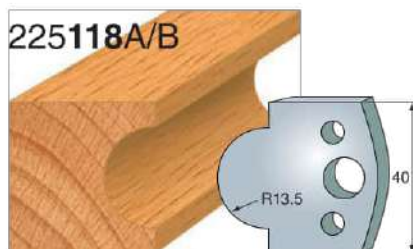
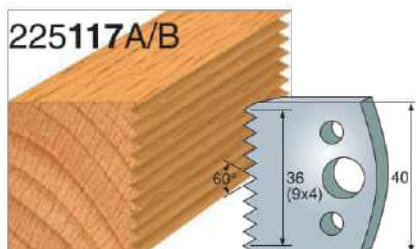
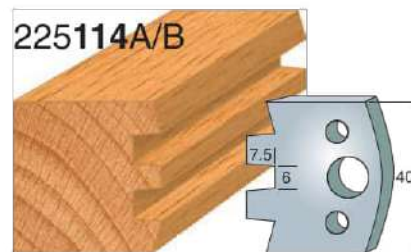
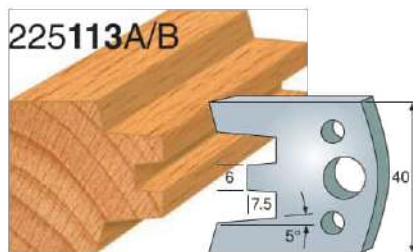
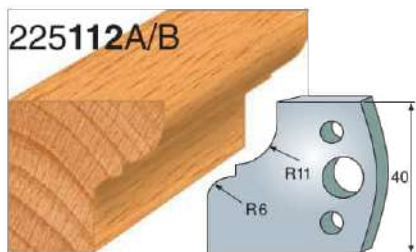



		Nr	€
A	profilový nôž	70500A~70558A	11,00 /ks
B	obmedzovač triesky	70500B~70558B	9,80 /ks

Štandardné profilové nože vyrobené z nástrojovej ocele. Nevhodné na obrábanie tvrdých drevin a MDF. Výrobná nepresnosť odpovedajúca hobby určeniu.

70.500 A/B

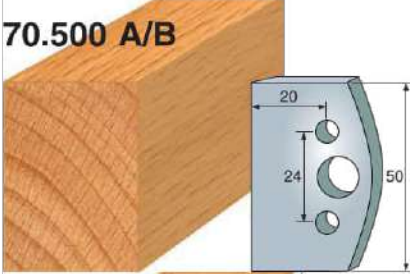

70.501A/B

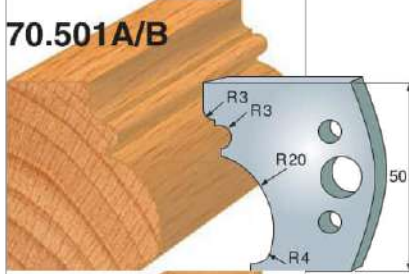

70.502 A/B

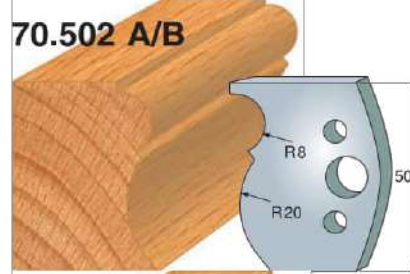

70.503 A/B

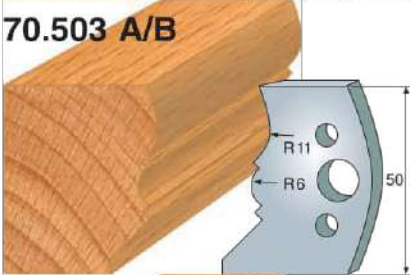

70.504 A/B



70.505 A/B

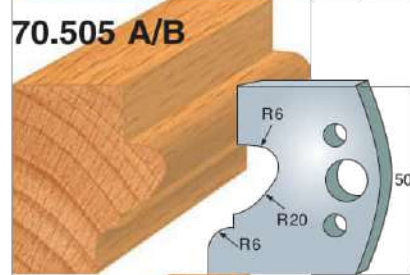

70.506 A/B

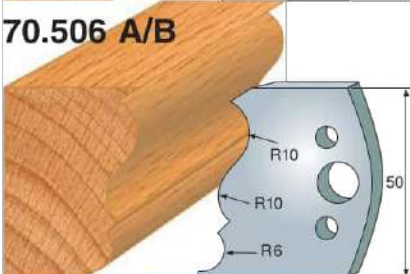

70.507 A/B

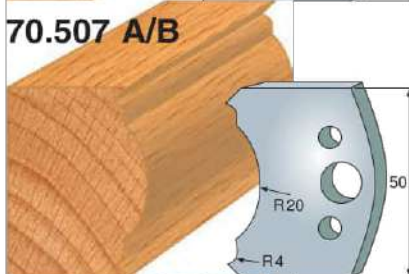

70.508 A/B

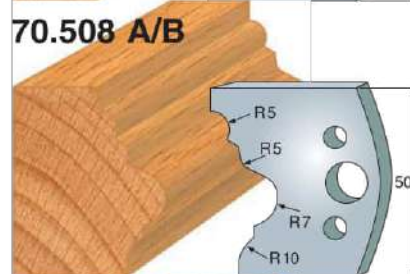

70.509 A/B

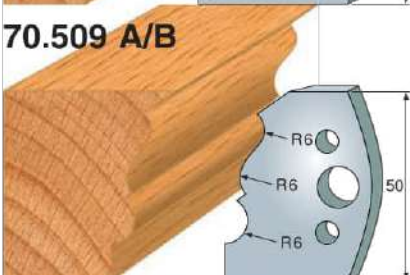

70.510 A/B

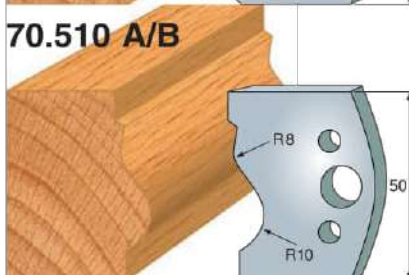

70.511 A/B

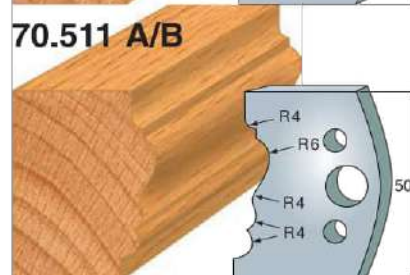

70.512 A/B

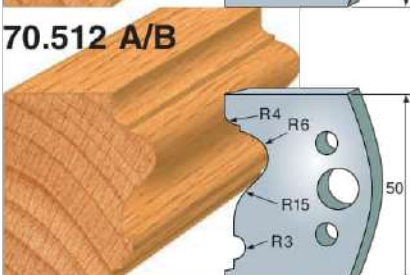

70.513 A/B

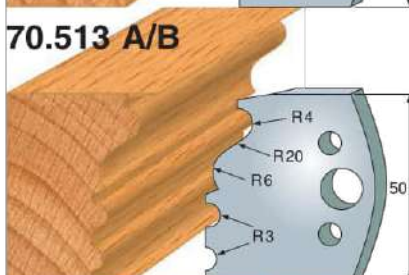

70.514 A/B

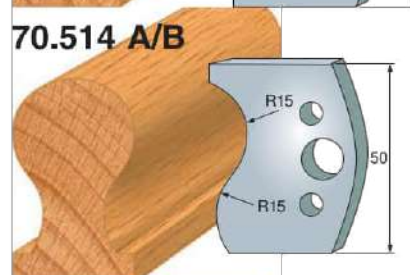

70.515 A/B

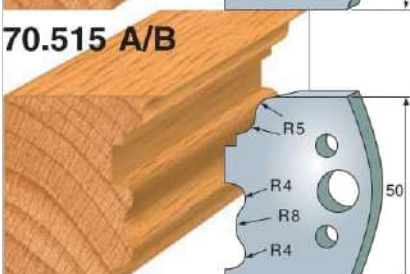

70.516A/B

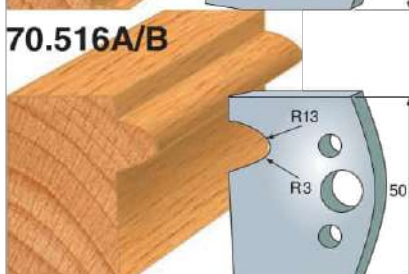

70.517 A/B

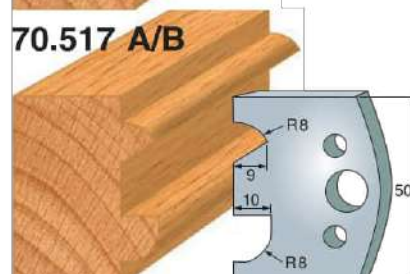

70.518 A/B

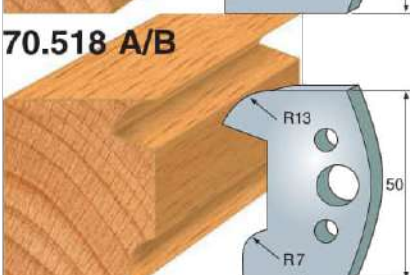

70.519 A/B

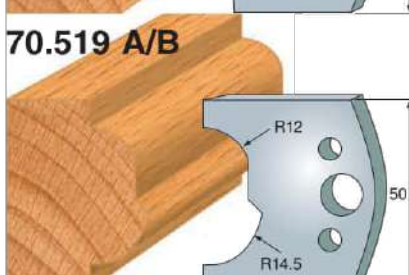

70.520 A/B

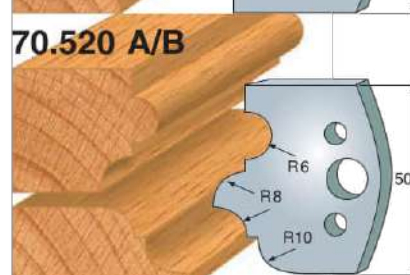

70.522 A/B

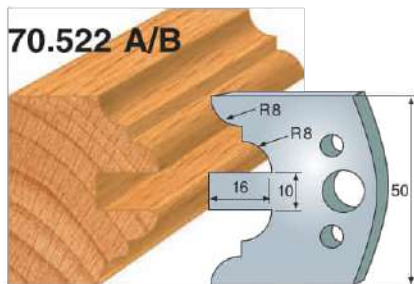

70.523 A/B

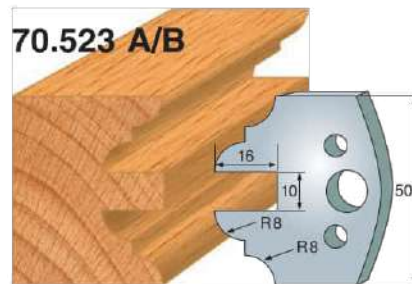

70.524 A/B

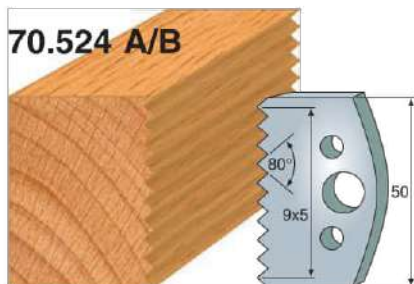

70.543 A/B

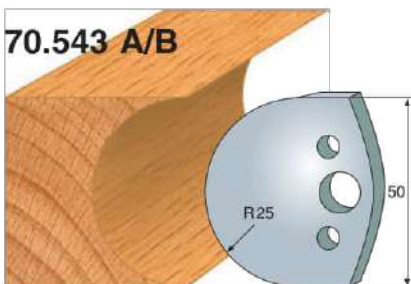

70.544 A/B

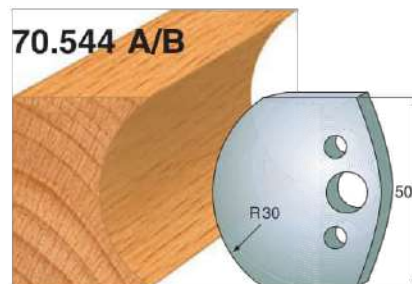

70.545 A/B

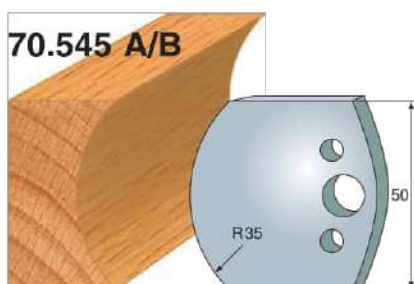

70.546 A/B

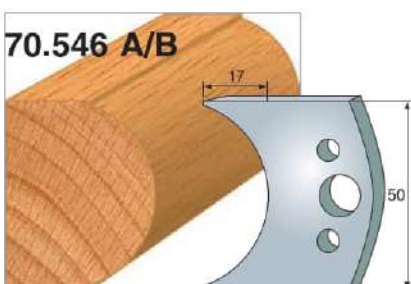

70.547 A/B

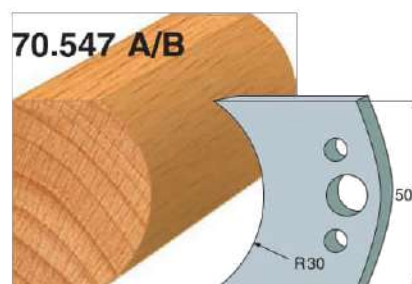

70.548 A/B

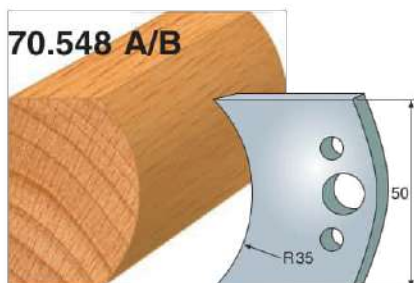

70.549 A/B

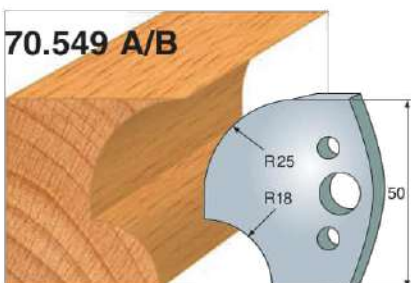

70.550 A/B

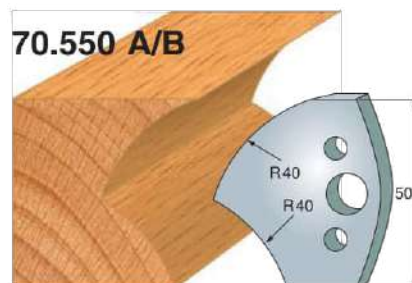

70.551 A/B

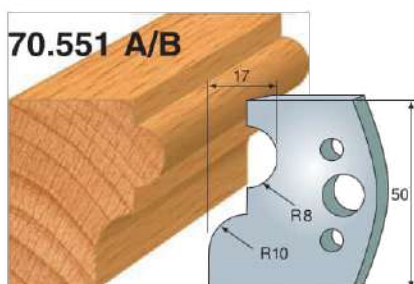

70.552 A/B

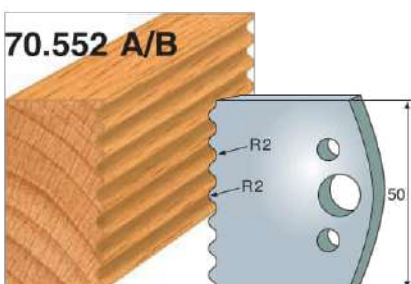

70.553 A/B

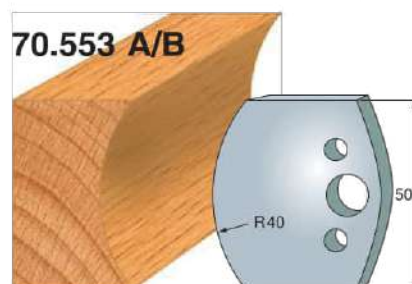

70.554 A/B

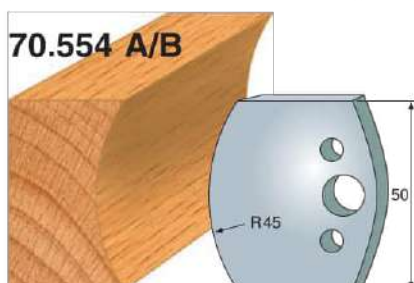

70.555 A/B

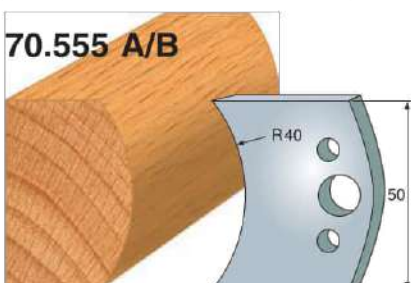

70.556 A/B

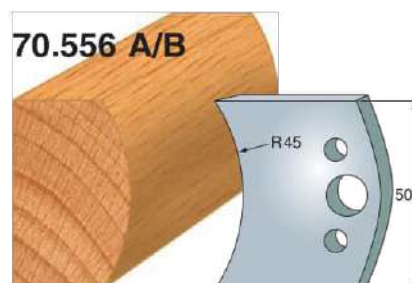

70.559 A/B

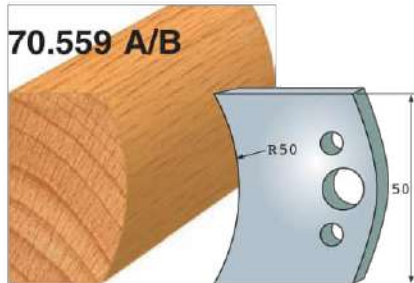

70.560A/B

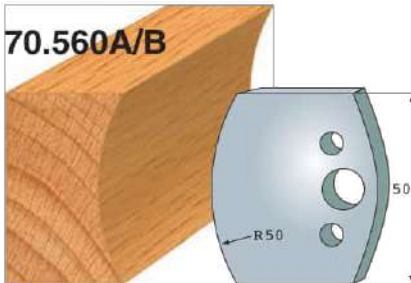

70.561 A/B

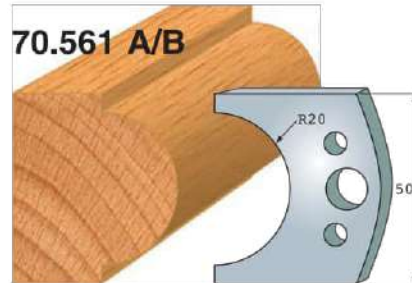

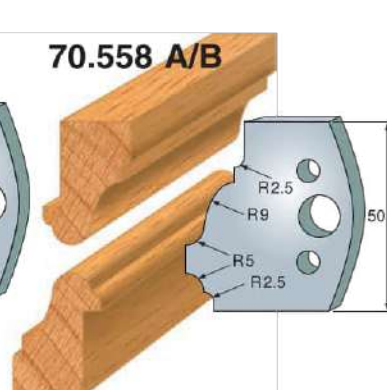
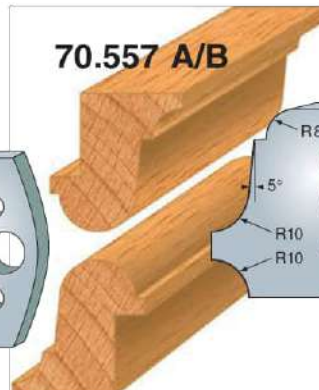
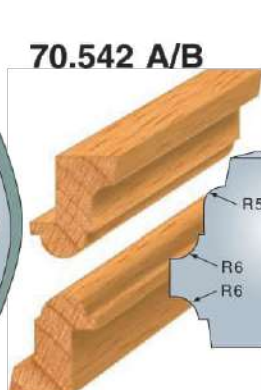
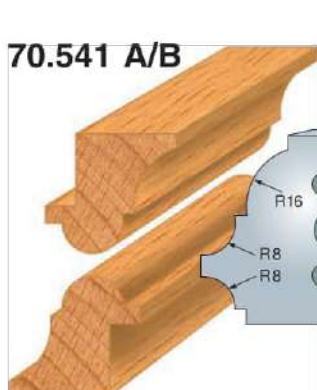
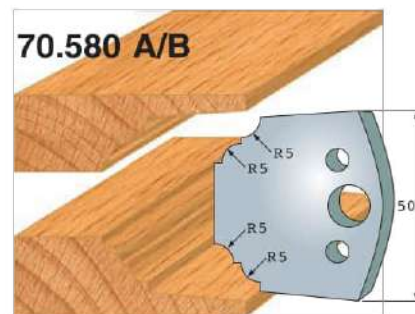
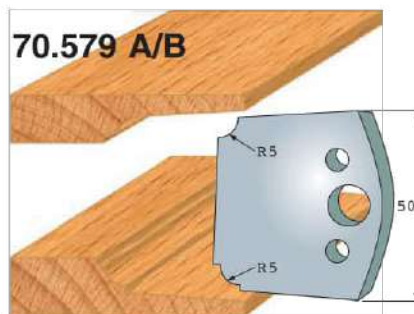
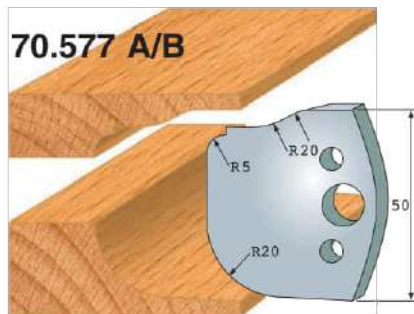
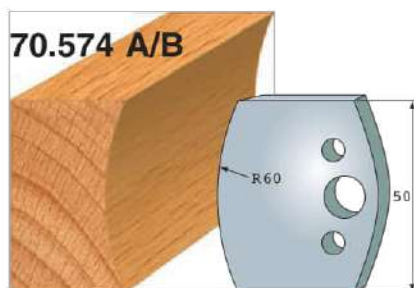
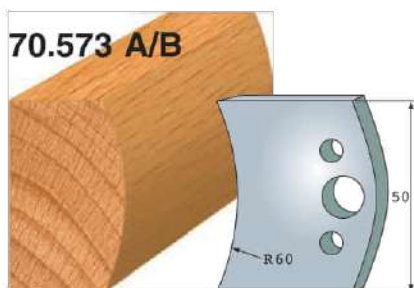
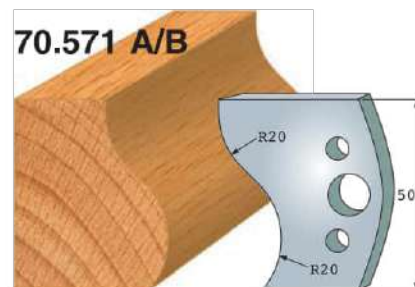
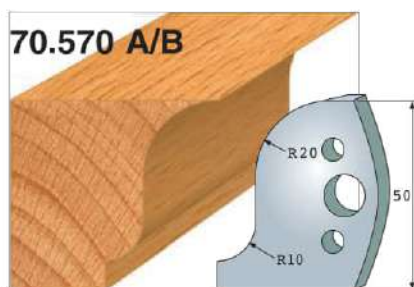
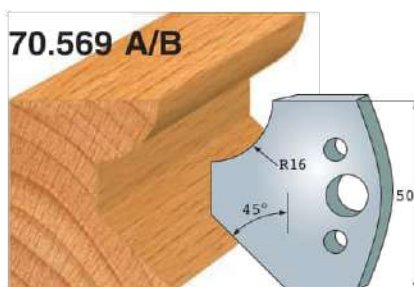
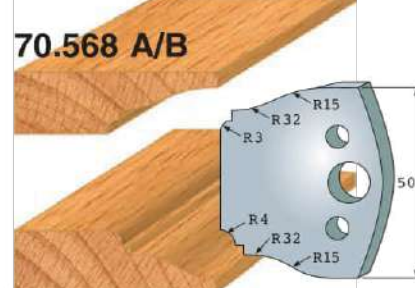
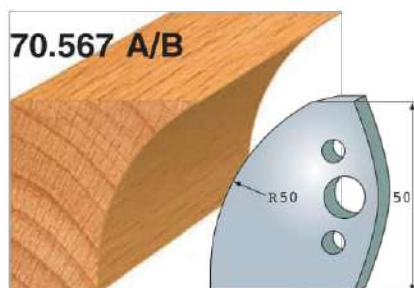
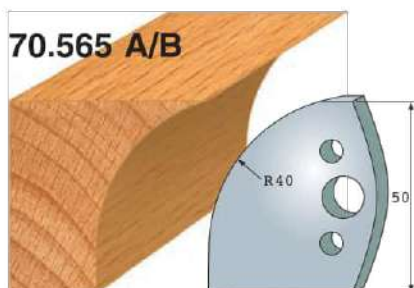
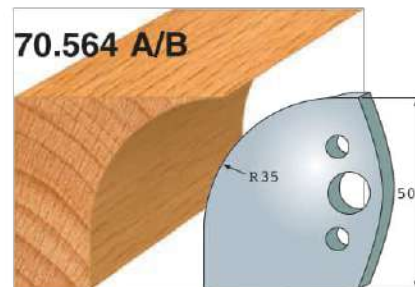
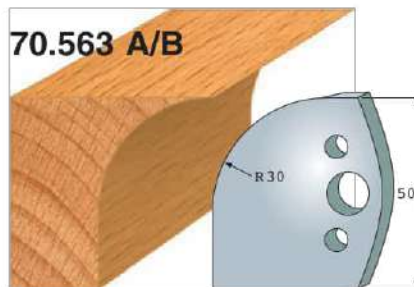
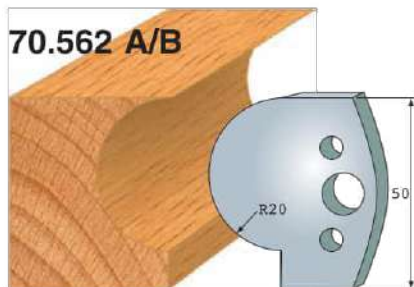

VBÍRANÉ ZÁKAZKOVÉ PROFILOVÉ NŮŽE

Profil DOMINO 8,10	Rozmer	Nr	€
nůž	40x4 HS	301B2341901A	32,90
obmedzovač	40x4 SP	301B2341901B	22,20

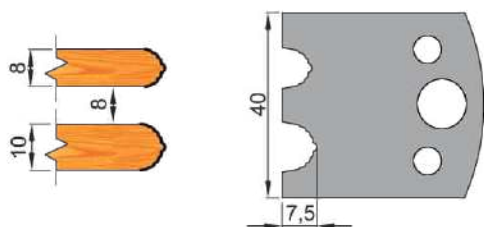

Profil DOMINO 12,14	Rozmer	Nr	€
nůž	40x4 HS	301B2341902A	32,92
obmedzovač	40x4 SP	301B2341902B	22,20

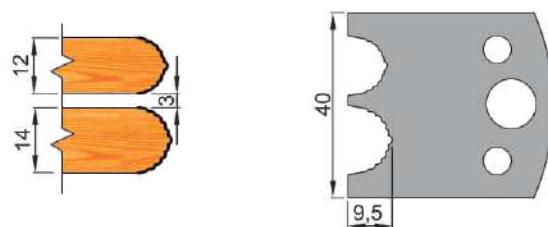

Profil ZÁRUBŇA	Rozmer	Nr	€
nůž	40x4 HS	301B2341903A	43,98
obmedzovač	40x4 HS	301B2341903B	40,64



Profil LISTELA	Rozmer	Nr	€
nůž	50x4 HS	301B2341904A	42,46
obmedzovač	50x4 SP	301B2341904B	27,53

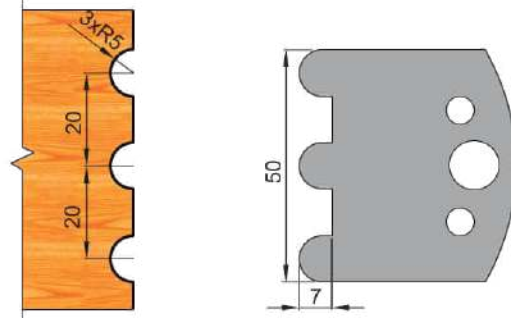

Profil RHOMBUS	Rozmer	Nr	€
nůž	50x4 HS	301B2341905A	43,98
obmedzovač	50x4 HS	301B2341905B	40,64

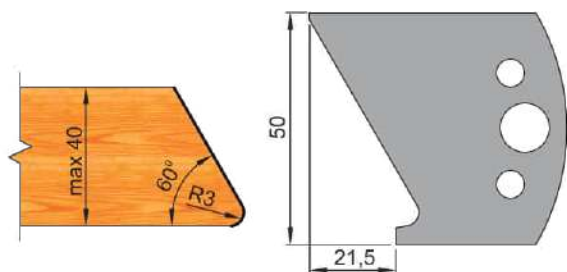

Profil TERASSO	Rozmer	Nr	€
nůž	50x4 HS	301B2341906A	42,46
obmedzovač	50x4 SP	301B2341906B	27,53

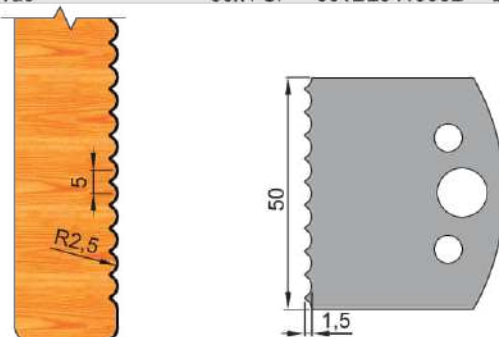

Profil DVEROVÝ FALC	Rozmer	Nr	€
nůž	50x4 HS	301B2341907A	43,98
obmedzovač	50x4 HS	301B2341907B	40,64

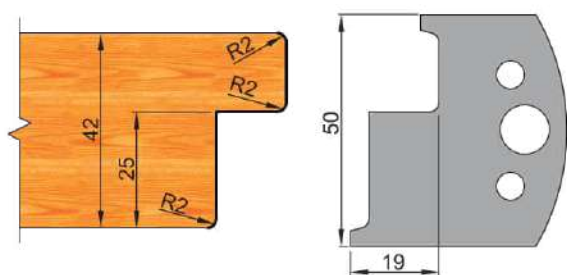

Profil DVEROVÝ FALC ŠÍKMÝ	Rozmer	Nr	€
nůž	50x4 HS	301B2341908A	43,98
obmedzovač	50x4 SP	301B2341908B	40,64

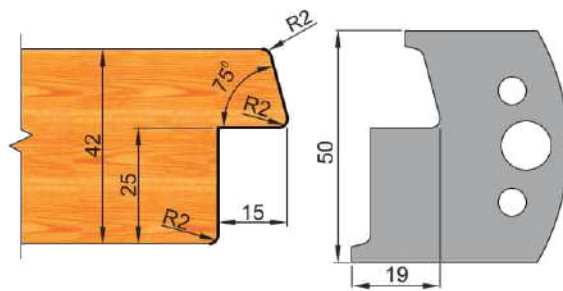

Profil DVERE RUSTIK 18	Rozmer	Nr	€
nůž	50x4 HS	301B2341909A	43,98
obmedzovač	50x4 HS	301B2341909B	43,98

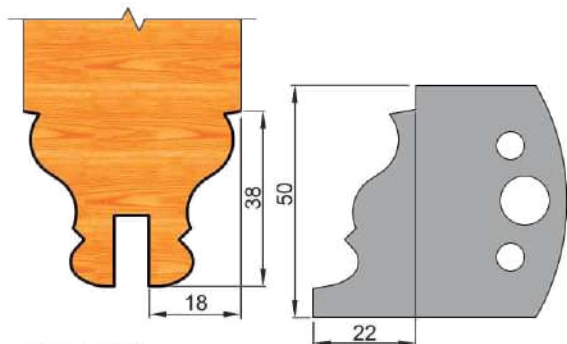

Profil DVERE RUSTIK 13	Rozmer	Nr	€
nůž	50x4 HS	301B2341910A	42,46
obmedzovač	50x4 SP	301B2341910B	27,53

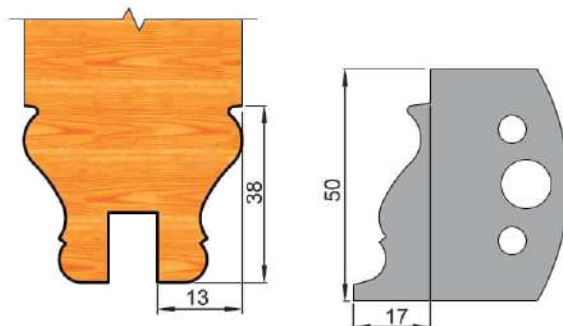

VYBRANÉ ZÁKAZKOVÉ PROFILOVÉ NÓŽE

SP, HS

Dvere	Nr	Nr	Nr	Nr	Nr	Rozmer	€				
pr.11	301B2341911A	pr.12	301B2341912A	pr.13	301B2341913A	pr.14	301B2341914A	pr.15	301B2341915A	50x4 HS nôž	36,30
pr.11	301B2341911B	pr.12	301B2341912B	pr.13	301B2341913B	pr.14	301B2341914B	pr.15	301B2341915B	50x4 SP obmedzovač	33,70

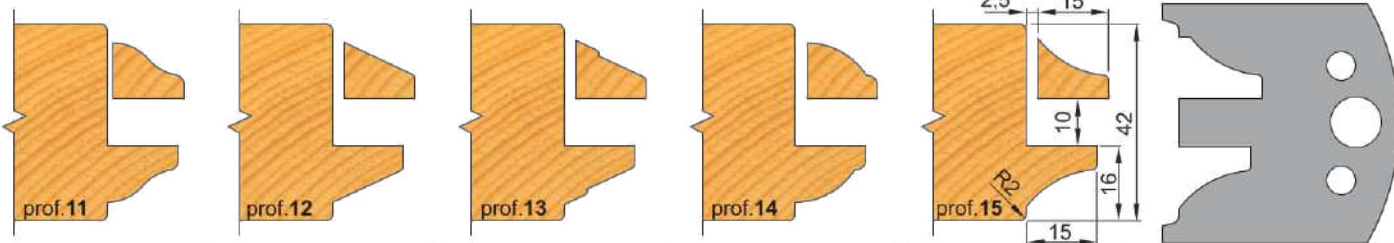

Dvere	Nr	Nr	Nr	Nr	Nr	Rozmer	€				
pr.16	301B2341916A	pr.17	301B2341917A	pr.18	301B2341918A	pr.19	301B2341919A	pr.20	301B2341920A	50x4 HS nôž	32,80
pr.16	301B2341916B	pr.17	301B2341917B	pr.18	301B2341918B	pr.19	301B2341919B	pr.20	301B2341920B	50x4 SP obmedzovač	18,50

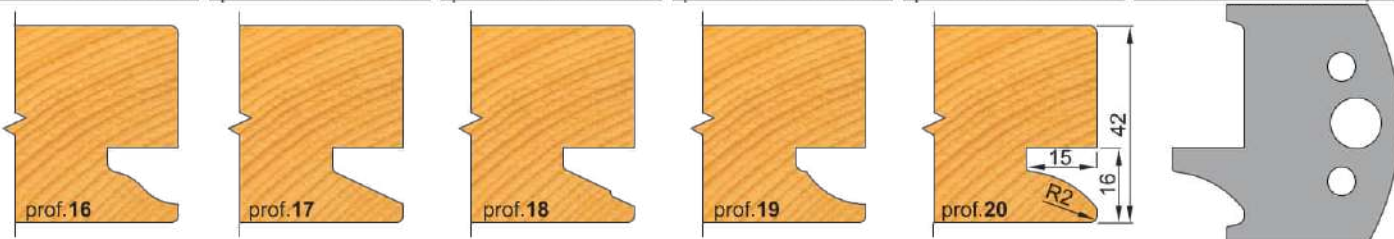

Profil RÍMSA KOLMÁ		Nr	€
nôž	SET 1xA+1xB	301B2341921A	81,56
obmedzovač	SET 1xA+1xB	301B2341921B	81,28

Profil RÍMSA ŠIKMÁ		Nr	€
nôž	SET 1xA+1xB	301B2341922A	84,92
obmedzovač	SET 1xA+1xB	301B2341922B	55,00

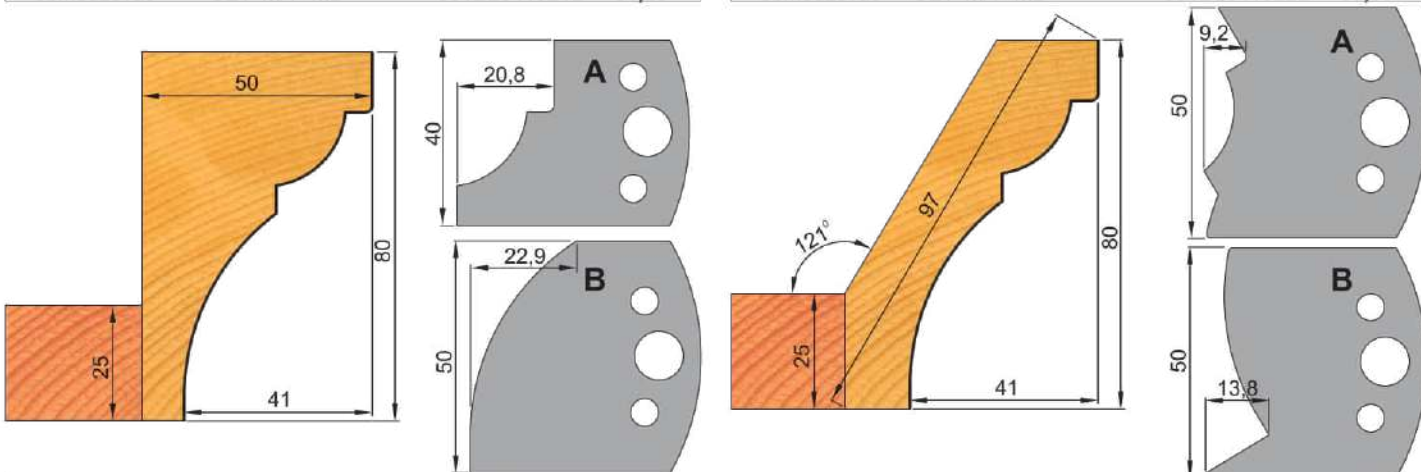

Profil DVIERKA		Rozmer	Nr	€	Nr	€
nôž	50x4 HS		301B2341923A	42,46	301B2341924A	43,98
obmedzovač	50x4 HS		301B2341923B	27,53	301B2341924B	40,64

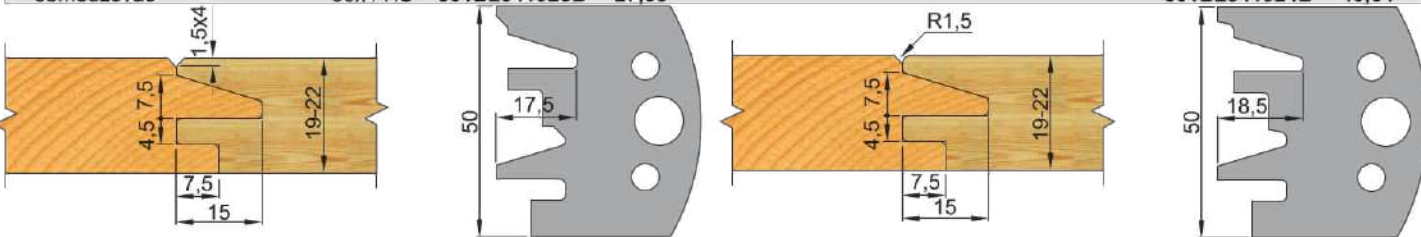

Profil KAĎA		Rozmer	Nr	€
nôž	SET 1xA+1xB	40x4 HS	301B2341926A	49,20
obmedzovač	SET 1xA+1xB	40x4 HS	301B2341926B	31,00

Profil MNOHOUHOLNÍK		Rozmer	Nr	€
nôž	SET 1xA+1xB	40x4 HS	301B2341927A	49,20
obmedzovač	SET 1xA+1xB	40x4 HS	301B2341927B	31,00

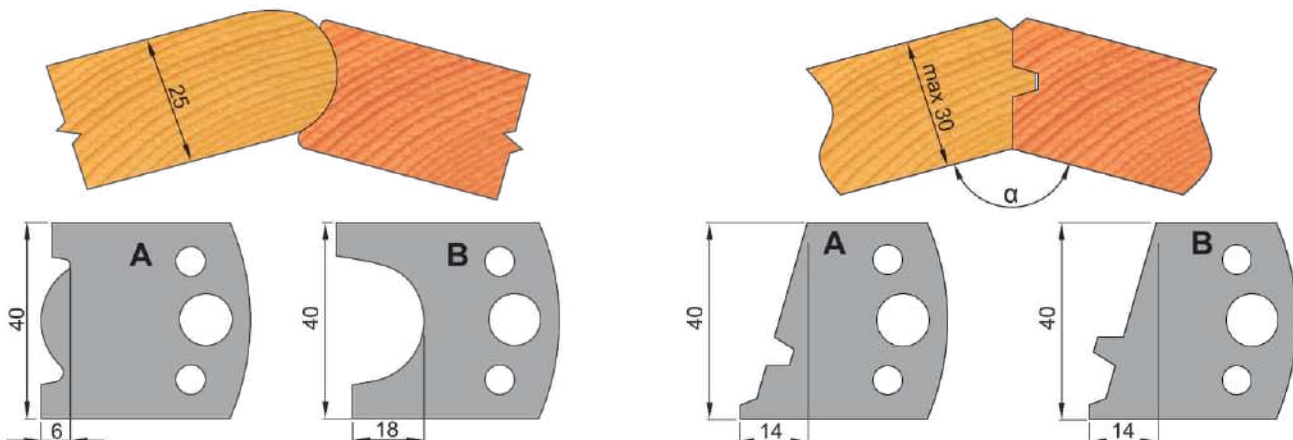



290 BLANKETOVÉ HLAVY



STANDARD		D=122			
ø D	B	ø d	Z	Nr	€
122	40	40	4	290AA	134,00
122	60	40	4	290BB	149,00
122	80	40	4	290CC	194,00
122	100	40	4	290GG	219,00
122	130	40	4	290DD	260,00
122	150	40	4	290HH	274,17
122	180	40	4	290FF	289,00
122	230	40	4	290EE	345,00

INDUSTRY		D=137			
ø D	B	ø d	Z	Nr	€
137	50	50	4	290AA137	208,90
137	60	50	4	290BB137	208,90
137	80	50	4	290CC137	251,70
137	100	50	4	290GG137	290,00
137	130	50	4	290DD137	346,30
137	150	50	4	290HH137	397,10
137	180	50	4	290FF137	461,45
137	230	50	4	290EE137	544,30

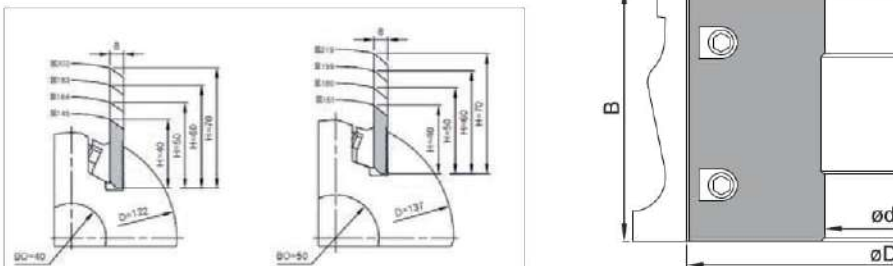

Osvedčený profilovací systém pre štvorstranné frézovalky.



HSK 85WE POWERLOCK HLAVY

HSK 85WE



ø D	B	Z	Nr	€
90	60	2	235T2060AAAAWA (R,L)	428,40
90	80	2	235T2060ABAAWA (R,L)	495,40
90	100	2	235T2060ACAAWA (R,L)	577,80
90	130	2	235T2060ADAAWA (R,L)	654,20
90	150	2	235T2060AEAAWA (R,L)	725,80
90	180	2	235T2060AFAAWA (R,L)	869,20
90	230	2	235T2060AGAAWA (R,L)	1014,00

ø D	B	Z	Nr	€
90	60	4	235T2060AABAWA (R,L)	534,60
90	80	4	235T2060ABBAWA (R,L)	619,00
90	100	4	235T2060ACBAWA (R,L)	680,60
90	130	4	235T2060ADBAWA (R,L)	769,40
90	150	4	235T2060AEBAWA (R,L)	853,60
90	180	4	235T2060AFBAWA (R,L)	1023,20
90	230	4	235T2060AGBAWA (R,L)	1193,00

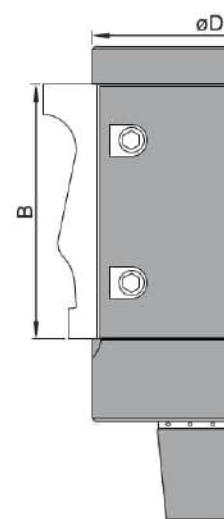

Výkonný priemerný frézovalcový systém pre SCM, WEINIG.
Umožňuje zachovanie nulového bodu aj po výmene frézovalcových hláv.

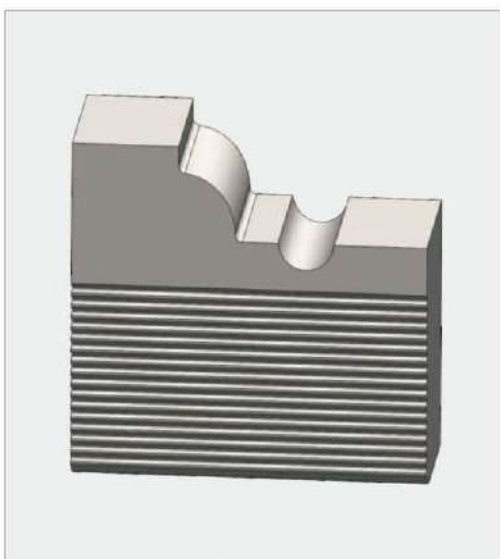

Ryhovaný BLANKET 6 HS (18%W)

B	Nr	€	B	Nr	€
50	222201	28,48	50	222200	35,83

Cena vyprofilovaného noža

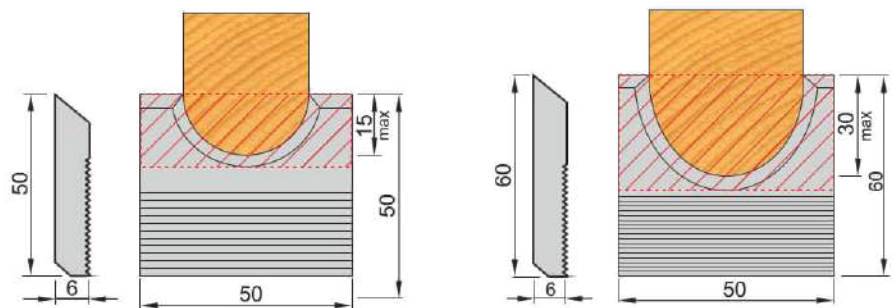

Váš profilový nôž vyrobíme do 48 hodín!

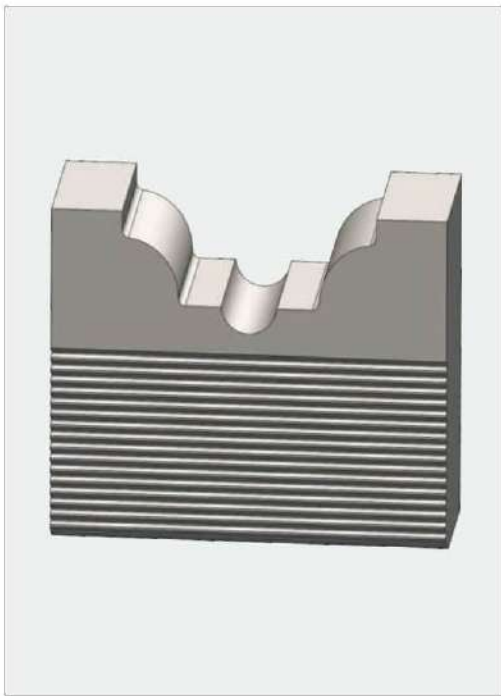

RYHOVANÝ BLANKET 8

HS (18%W)

B	Nr	€
40	222203	24,90
60	222205	34,40
80	222207	43,98
90	2222084	44,20
100	222214	53,50
130	222209	67,80
150	2222102	77,40
180	2222106	91,60
230	222211	115,50

Cena vyprofilovaného noža

B	Nr	€
40	222204	33,20
60	222206	46,80
80	222208	59,00
90	2222085	67,20
100	222215	74,00
130	222210	94,50
150	2222101	108,00
180	2222107	128,60
230	222213	162,70

Cena vyprofilovaného noža

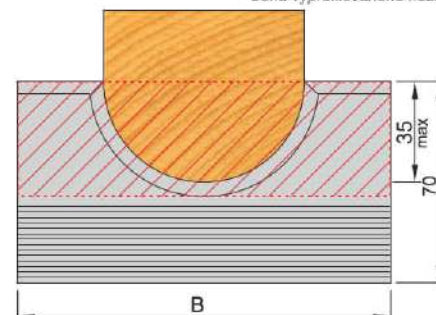
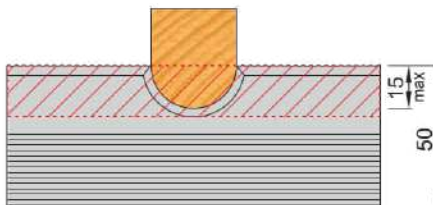

Profilové Blankety pre obrábanie masívneho dreva.

Váš profilový nôž vyrobíme do 48 hod.!

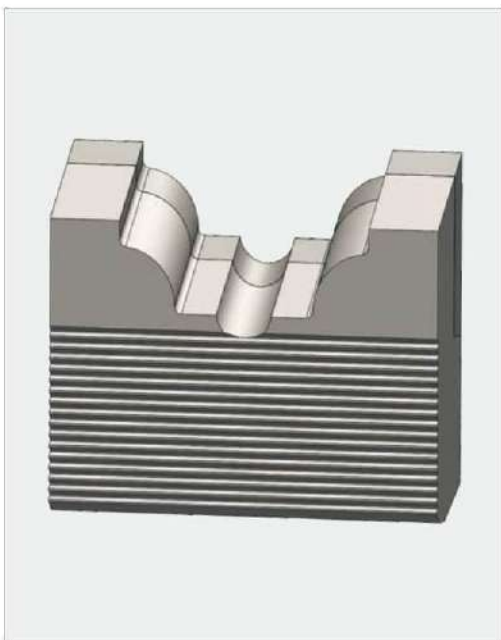

RYHOVANÝ BLANKET MASÍV

HW

B	Nr	€
40	54030254	51,80
60	540103261	69,31
80	540103262	86,72
100	540103263	104,02
130	540103264	130,82

Cena vyprofilovaného noža

B	Nr	€
40	540114868	70,16
60	540109128	95,06
80	540109129	118,79
100	540109130	142,21
130	540109131	179,77

Cena vyprofilovaného noža

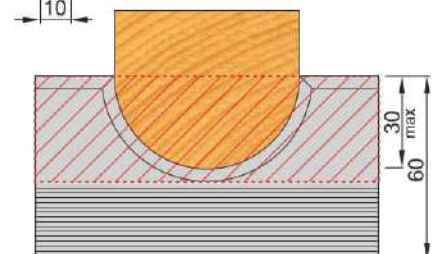
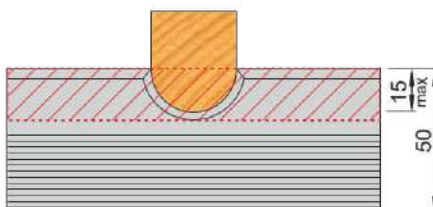

Profilové Blankety pre obrábanie dreva a aglomerátov.

Váš profilový nôž vyrobíme do 48 hod.!



RYHOVANÝ BLANKET DOUBLEBACK

HW

B	Nr	€
40	54024091	70,69
50	54043928	84,08
60	54024124	97,59
80	54024157	121,54
100	54023985	155,40
120	54023991	152,13
130	54024025	217,96

B	Nr	€
50	54043932	90,20
60	54024135	104,76
80	54024168	130,50
100	54023969	166,80
120	54024002	195,28
130	54024036	222,61

B	Nr	€
40	54024101	27,75
50	54043958	27,96
60	54024134	31,76
80	54024167	39,46
100	54023968	47,37
120	54024001	55,28
130	54024035	61,50

B	Nr	€
50	54043959	32,39
60	54024145	43,04
80	54024178	46,42
100	54023979	63,93
120	54024012	62,14
130	54024046	69,00

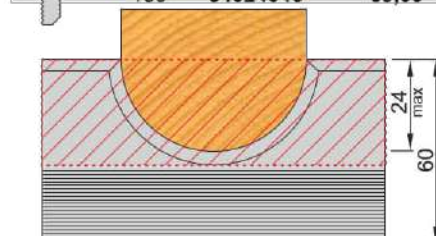
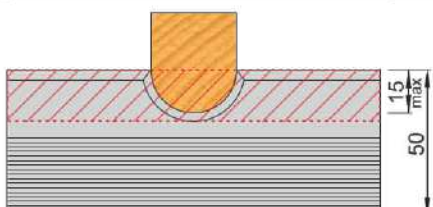

Profilové Blankety pre obrábanie dreva a aglomerátov.

Váš profilový nôž vyrobíme do 48 hod.!





04120 **UNIVERZÁLNE FRÉZOVACIE HLAVY LIGHT 60** **HS**

$\varnothing D$	B	$\varnothing d$	Nr	€
120	60	30	7004120060130A	145,00

Profilový nôž HSS18%W

Cena vyprofilovaného noža

49,00

príklady profilov

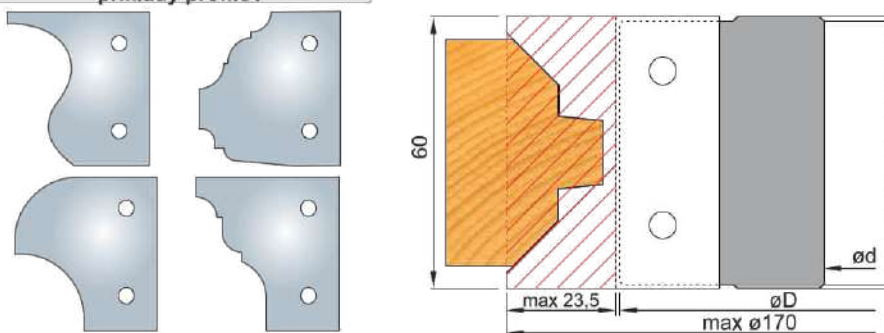

Hobby frérovacie nosiče určené na malosériovú výrobu. Nízka hmotnosť je výhodou hlavne pre malé spodné frérovacie.



04094 **UNIVERZÁLNE FRÉZOVACIE HLAVY LIGHT 90** **HS**

$\varnothing D$	B	$\varnothing d$	Nr	€
90	90	30	7004094090030A	138,00

Profilový nôž HSS18%W

Cena vyprofilovaného noža

59,00

príklady profilov

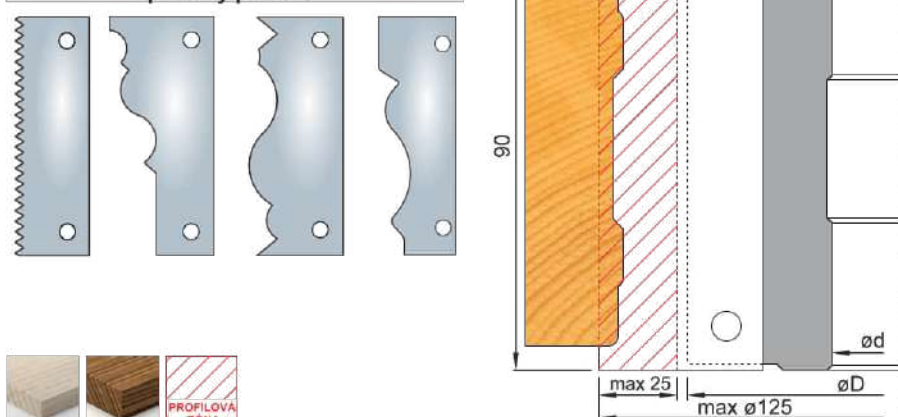

Hobby frérovacie nosiče určené na malosériovú výrobu. Nízka hmotnosť a malý priemer je výhodou hlavne pre malé spodné frérovacie.



TSP 152 **UNIVERZÁLNE SUPERPROFILOVÉ HLAVY 30** **HW**

TVAR	$\varnothing D$	B	$\varnothing d$	Nr	€
C	120	30	30	280TSP152C	142,50
D	120	30	30	280TSP152D	142,50
E	120	30	30	280TSP152E	142,50

Profilový nôž HW

Cena vyprofilovaného noža

21,20

Oporný nôž SP

Cena vyprofilovaného noža

19,40

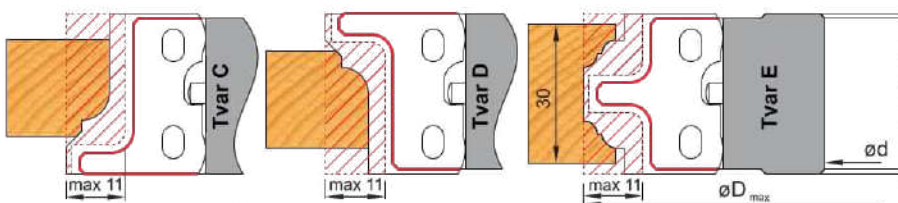

Frérovacie nosiče určené pre zákazkové profilové nože. Veľkosť profilovej zóny s kombináciou tvaru použitého nosiča dávajú možnosti pre široké spektrum použitia. Nosiče sú v dvojzozvom prevedení, určené sú primárne pre spodné frérovacie.



TSP 154-156 UNIVERZÁLNE SUPERPROFILOVÉ HLAVY

HW



TSP 154 - HLAVY 40

TVAR	ø D _{max}	B	ø d	Z	Nr	€
A	137	40	30(40)	3	280TSP154AA	175,-
A	178	40	40	4	280TSP154AB	245,-
B	125	40	30	2	280TSP154B	115,-
C	137	40	30(40)	3	280TSP154CA	175,-
C	178	40	40	4	280TSP154CB	245,-
D	137	40	30(40)	3	280TSP154DA	175,-
D	178	40	40	4	280TSP154DB	245,-
E	137	40	30(40)	3	280TSP154EA	175,-

	t _{max}	€
Profilový nôž HW	13	Cena vyprofilovaného noža 21,50
Oporný nôž SP	13	Cena vyprofilovaného noža 19,50
Profilový nôž HW	19	Cena vyprofilovaného noža 27,90
Oporný nôž SP	19	Cena vyprofilovaného noža 21,70

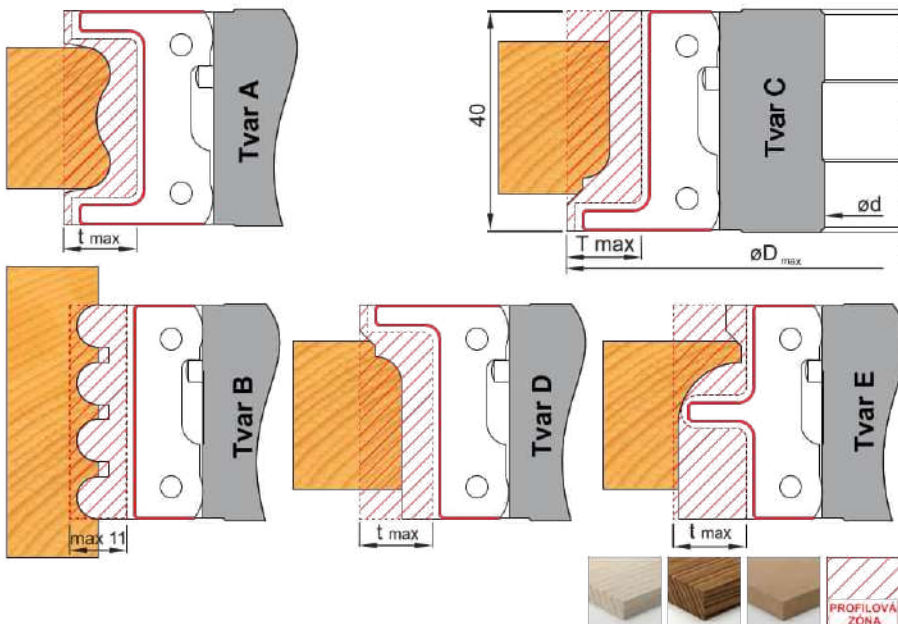

Široký sortiment frézovacích nosičov určených pre zákazkové profilové nože. Veľkosť profilovej zóny s kombináciou tvaru použitého nosiča dávajú možnosti pre široké spektrum použitia pre frézovanie masívu a MDF. Nosiče s otvorom 30mm sú pre spodné frézovačky. Nosiče s otvorom 40mm pre štvorstranné frézovačky.

TSP 156 - HLAVY 60

TVAR	ø D _{max}	B	ø d	Z	Nr	€
A	180	60	40	4	280TSP156A	375,-
C	180	60	40	4	280TSP156C	375,-
D	180	60	40	4	280TSP156D	375,-

	€
Profilový nôž HW	Cena vyprofilovaného noža 32,70
Oporný nôž SP	Cena vyprofilovaného noža 30,50

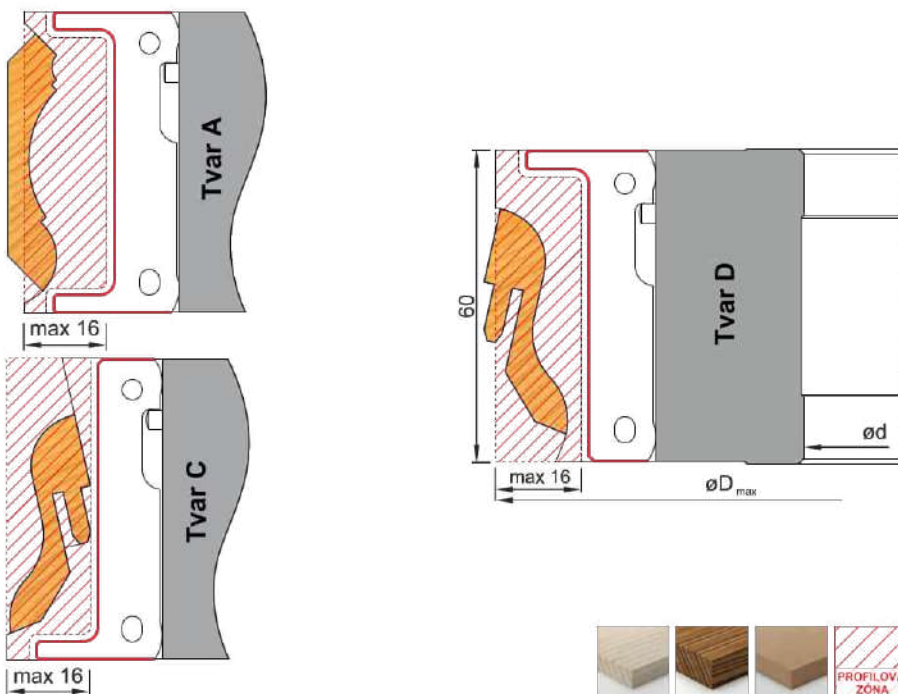

Frézovacie nosiče určené pre zákazkové profilové nože. Veľkosť profilovej zóny s kombináciou tvaru použitého nosiča dávajú možnosti pre široké spektrum použitia. Nosiče sú určené výhradne pre štvorstranné frézovačky.

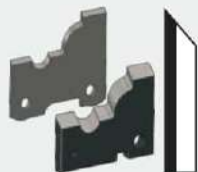

TERSA LAMEL

TERSA



ø d	B	Z	€
100	260	4	1 175,-
100	300	4	1 270,-
100	350	4	1 410,-
100	400	4	1 510,-
100	410	4	1 530,-
100	430	4	1 580,-
100	500	4	1 640,-
110	260	4	1 385,-
110	300	4	1 465,-
110	350	4	1 565,-
110	400	4	1 785,-
110	410	4	1 810,-
110	500	4	1 955,-
120	350	4	1 705,-
120	400	4	1 810,-
120	410	4	1 845,-
120	430	4	1 900,-
120	500	4	2 015,-
120	510	4	2 100,-
120	520	4	2 145,-
120	530	4	2 180,-
120	600	4	2 420,-
120	610	4	2 515,-
120	630	4	2 560,-
120	640	4	2 570,-

TERSA MONO

TERSA



ø d	B	Z	€
125	350	4	1 745,-
125	400	4	1 900,-
125	410	4	1 955,-
125	430	4	2 040,-
125	500	4	2 190,-
125	510	4	2 250,-
125	520	4	2 295,-
125	530	4	2 325,-
125	600	4	2 455,-
125	610	4	2 535,-
125	630	4	2 625,-
125	640	4	2 635,-
140	400	4	1 920,-
140	450	4	2 090,-
140	500	4	2 265,-
140	600	4	2 550,-
140	640	4	2 915,-
140	760	4	3 405,-
140	810	4	3 705,-
140	400	6	2 010,-
140	450	6	2 215,-
140	500	6	2 365,-
140	600	6	2 635,-
140	640	6	3 025,-
140	760	6	3 490,-
140	810	6	3 835,-

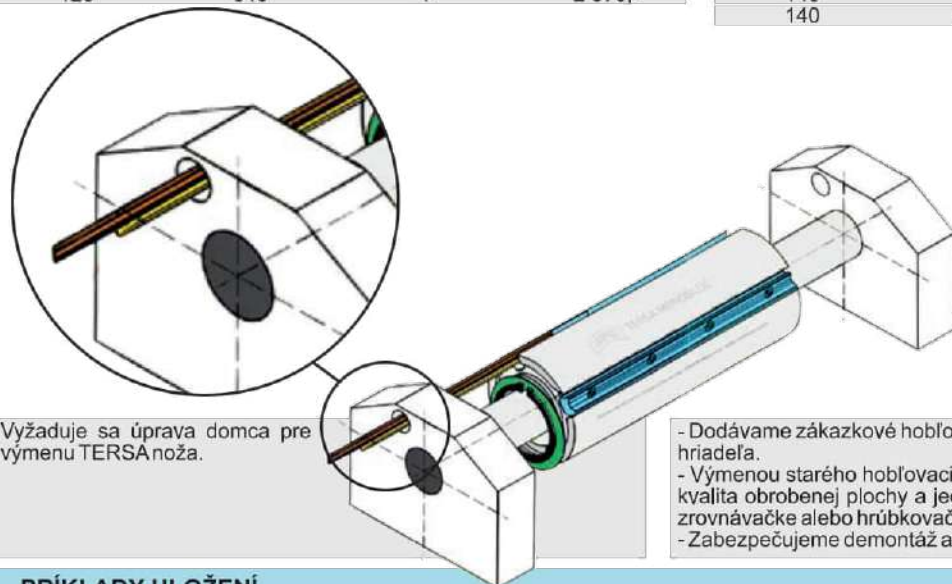

Vyžaduje sa úprava domca pre výmenu TERSA noža.

- Dodávame zákazkové hobľovacie hriadeľa pre rôzne typy uloženia a výstupu hriadeľa.

- Výmenou starého hobľovacieho hriadeľa za TERSA valec sa zásadne zvýši kvalita obrobenej plochy a jednoduchosť a výmena noža na Vašej pôvodnej zrovnávačke alebo hrúbkovačke.

- Zabezpečujeme demontáž a skreslenie starého a montáž nového hriadeľa.

PRÍKLADY ULOŽENÍ



Na požiadanie zameráme a skreslíme presné uloženie Vášho starého hobľovacieho valca.

SPIRAL Z3



ø d	B	Z	€
62	260	41	900,-
72	300	48	1 000,-
80	310	51	1 100,-
90	410	66	1 300,-
100	430	69	1 400,-
110	500	81	1 600,-
120	350	57	1 655,-
120	400	66	1 770,-
120	410	66	1 795,-
120	430	69	1 850,-
120	500	81	1 980,-
120	510	84	2 070,-
120	520	84	2 110,-
120	530	87	2 150,-
120	600	99	2 395,-
120	610	99	2 490,-
120	630	102	2 540,-
120	640	105	2 555,-
120	710	117	2 830,-
120	810	132	3 230,-
120	900	147	3 590,-
120	1000	165	3 990,-
125	350	57	1 700,-
125	400	66	1 860,-
125	410	66	1 920,-
125	430	69	2 005,-
125	500	81	2 160,-
125	510	84	2 225,-
125	520	84	2 275,-
125	530	87	2 300,-
125	600	99	2 440,-
125	610	99	2 515,-
125	630	102	2 610,-
125	640	105	2 670,-
140	400	66	1 880,-
140	450	75	2 060,-
140	500	81	2 240,-
140	600	99	2 525,-
140	640	105	2 910,-
140	760	123	3 405,-
140	810	132	3 735,-

SPIRAL Z4



ø d	B	Z	€
90	410	68	1 400,-
100	430	72	1 500,-
110	500	84	1 700,-
120	350	60	1 740,-
120	400	68	1 860,-
120	410	68	1 885,-
120	430	72	1 945,-
120	500	84	2 080,-
120	510	88	2 175,-
120	520	88	2 215,-
120	530	92	2 260,-
120	600	100	2 515,-
120	610	104	2 615,-
120	630	108	2 670,-
120	640	108	2 683,-
120	710	120	2 980,-
120	810	136	3 400,-
120	900	152	3 780,-
120	1000	168	4 200,-
125	350	60	1 785,-
125	400	68	1 995,-
125	410	68	2 015,-
125	430	72	2 105,-
125	500	84	2 270,-
125	510	88	2 335,-
125	520	88	2 390,-
125	530	92	2 415,-
125	600	100	2 560,-
125	610	104	2 640,-
125	630	108	2 740,-
125	640	108	2 805,-
140	400	68	1 975,-
140	450	76	2 165,-
140	500	84	2 350,-
140	600	100	2 650,-
140	640	108	3 055,-
140	760	120	3 575,-
140	810	136	3 920,-

NOŽE

HW

nož SPIRAL rovný

15x15x2,5

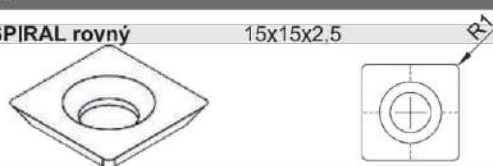

nož SPIRAL zaoblený

15x15x2,5



- Dodávame zákazkové hobľovacie hriadele pre rôzne typy uloženia a výstupu hriadeľa.
- Výmenou starého hobľovacieho hriadeľa za SPIRAL valec sa zásadne zvýši produktivita a životnosť pôvodnej zrovnávačky alebo hrúbkovačky a významne zníži hlučnosť.
- Zabezpečujeme demontáž a skreslenie starého a montáž nového hriadeľa.

PRÍKLADY ULOŽENÍ

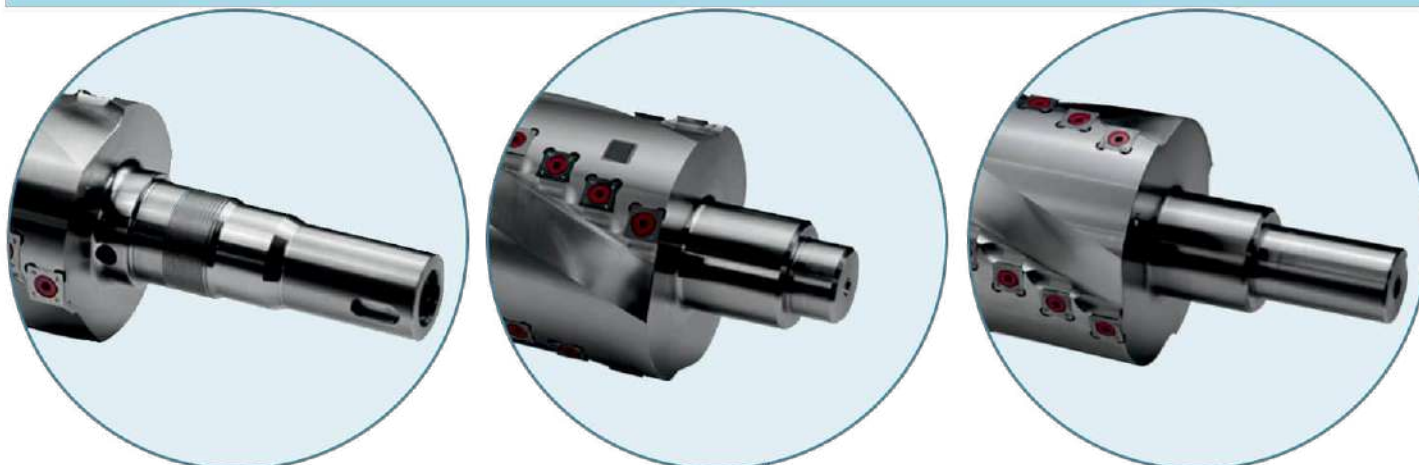

Na požiadanie zameráme a skreslíme presné uloženie Vášho starého hobľovacieho valca.





415 - R		REFERENČNÉ FRÉZY		HW	
$\varnothing D$	B	$\varnothing d$	Z	Nr	€
120	12,5	35	2+2	6150415R12035	152,80
140	12,5	40	2+2	6150415R14040	152,80
145	12,5	40	2+2	6150415R14540	152,80
150	12,5	40	2+2	6150415R15040	152,80

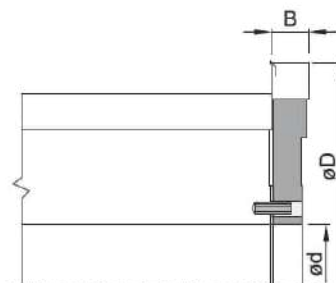

TERSA 108		REFERENČNÉ FRÉZY		HW	
$\varnothing D$	B	$\varnothing d$	Z	Nr	€
125	12,5	35		23410812535	165,00
145	12,5	40		23410814540	175,00
150	12,5	40		23410815040	195,00

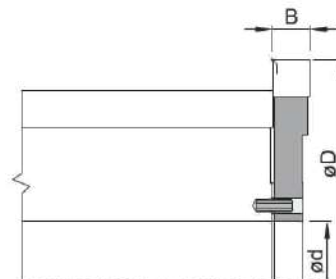

K410		FRÉZY PRE DRÁŽKOVANÉ STOLY		HW	
$\varnothing D$	B	$\varnothing d$	Z	Nr	€
125	9	40	2+4	615K410120940	202,00
125	10	40	2+4	615K410121040	202,00
125	12,5	40	2+4	615K410121240	202,00
125	17	40	2+2	615K410121740	198,00
125	20	40	2+2	615K410122040	198,00
140	12,5	40	2+4	615K410141240	202,00
140	20	40	2+2	615K410142040	198,00

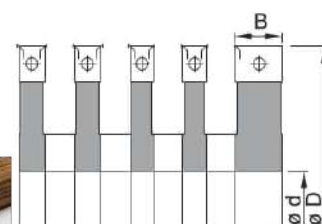

Drážkovacie frézy pre vodiace drážky v spodnom stole štvorstranných frézovačiek.



K416		NADSTAVITELNÉ ŽILETKOVÉ VALCE		HW	
$\varnothing D$	B	$\varnothing d$	Z	Nr	€
125	30	40	4	615K416123040	158,00
125	50	40	4	615K416125040	166,00

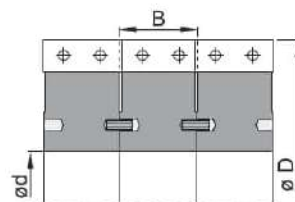

Segmentové frézy je možné ich kombináciou vyskladať na požadovanú dĺžku hriadeľa. Spirálové usporiadanie jednotlivých nástrojov umožňuje plynulý odvod triesky, vhodný najmä ako hrubovací nástroj.



TP05M		HOBLOVACIE VALCE		(HW), HS	
$\varnothing D$	B	$\varnothing d$	Z	Nr	€
ALU 125	100	40 (30,35)	4	280TP05M100	225,00
ALU 125	130	40 (30,35)	4	280TP05M130	243,00
ALU 125	150	40 (30,35)	4	280TP05M150	261,00
ALU 125	180	40 (30,35)	4	280TP05M180	297,00
ALU 125	230	40 (30,35)	4	280TP05M230	369,00
ATYP 100~180	60~300		2~8		cena na vyžiadanie

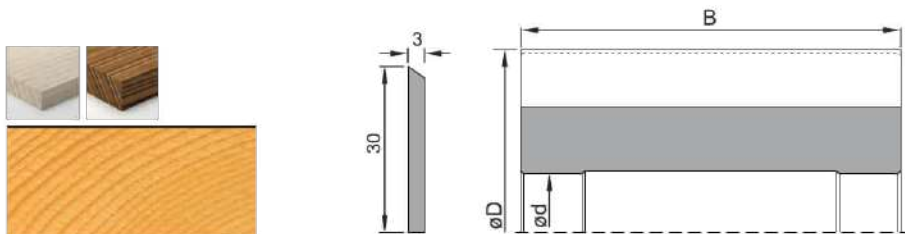

Štandardné AL hobľovacie valce, osadené nožmi v kvalite HS. Iné rozmery valcov na vyžiadanie.



R2000		TERSА		SP, HS, HW	
$\varnothing D$	B	$\varnothing d$	Z	Nr	€
100	100	35	4	23410010035	709,00
100	190	35	4	23410019035	903,00
125	100	40	4	23412510040	804,00
125	180	40	4	23412518040	987,00
125	230	40	4	23412523040	1129,00
ATYP 100~180	60~300		2~8		cena na vyžiadanie

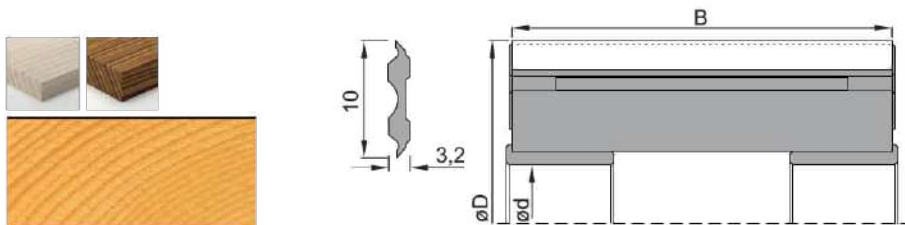

Samocentrické valce, systém TERSA. Upínanie nožov je odstredivou silou. Valce sú primárne určené ako dokončovacie – vynikajúca kvalita obrobenej plochy. Nie sú vhodné ako univerzálny nástroj.



T207		CENTRO HOBLOVACIE VALCE		HW, HS	
$\varnothing D$	B	$\varnothing d$	Z	Nr	€
ALU 125	130	40	4	1115330130125	436,00
ALU 125	190	40	4	1115330190125	523,00
ALU 125	240	40	4	1115330240125	617,00
ATYP 100~180	60~300		2~8		cena na vyžiadanie

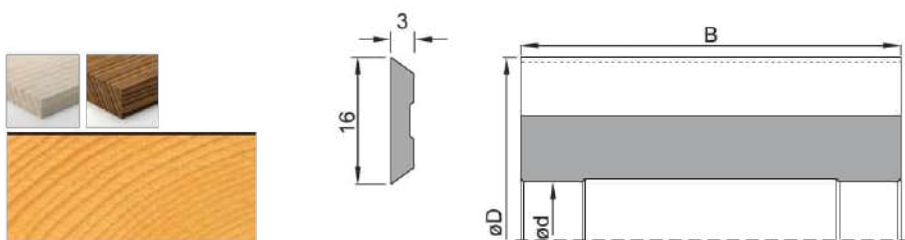

Samocentrické AL hobľovacie valce, systém CENTROLOCK. Upínanie nožov je odstredivou silou. Valce sú osadené nožmi v kvalite HS. Vďaka samocentrickému uloženiu nožov a ich dostatočnej pevnosti sú optimálnou voľbou v pomere cena/výkon.



T207R		CENTRO HOBLOVACIE VALCE SO ZRÁŽACÍMI ELEMENTAMI		HW	
$\varnothing D$	B	$\varnothing d$	Z	Nr	€
ALU 125	130	40	4+2	235T207SR12513F	832,00
ALU 125	150	40	4+2	235T207SR12515F	910,00
ALU 125	230	40	4+2	235T207SR12523F	1131,00
ATYP 100~180	60~300		2~8		cena na vyžiadanie

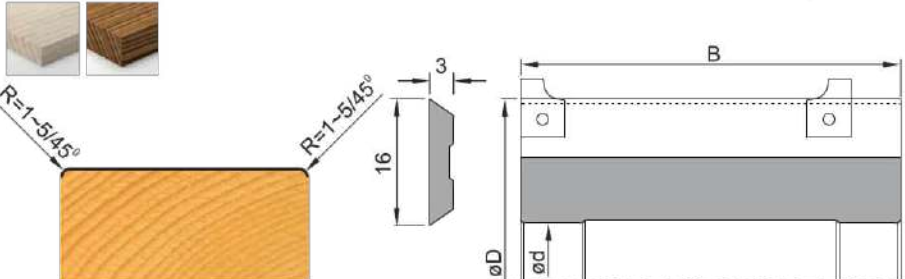

Ide o konštrukčnú modifikáciu valcov T207 doplnených o možnosť zaobľovania (R=1~5mm) a zrážania hrán (45°). Nástroje sú určené predovšetkým na vertikálne hriadele.





T209 ŠPIRÁLOVÉ TANGENCIÁLNE VALCE						HW
ø D	B	ø d	Z	Nr	€	
125	98	40	2+2	235T209120984A	339,00	
125	134	40	2+2	235T209121344A	371,00	
125	182	40	2+2	235T209121824A	516,00	
125	206	40	2+2	235T209122064A	580,00	
125	230	40	2+2	235T209122304A	636,00	
ATYP	80~180	60~180	2+2~4+4	cena na vyžiadanie		

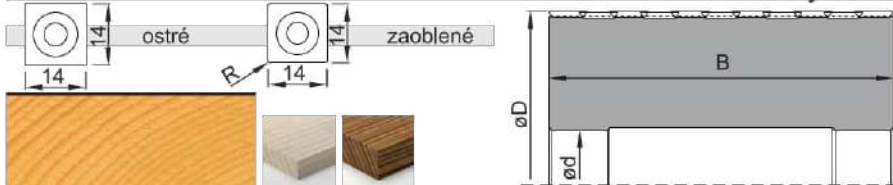

Špirálové AL hobľovacie valce na veľké úbery materiálu. Obzvlášť vhodné na tvrdé dreveny. Obrobeneý povrch je konštrukčnej kvality. Hobľovacie valce je možné dodať aj v prevedení Z=3. Nosič môže byť pre vysoké nasadenie v ocelovom vyhotovení. Pre montáž žiletiek za účelom správneho zoradenia odporúčame použiť momentový kľúč.



415 ŠPIRÁLOVÉ RADIÁLNE VALCE						HW
ø D	B	ø d	Z	Nr	€	
ALU 100	115	35	3+3	6150415E11135	364,80	
ALU 100	180	35	3+3	6150415E11835	613,44	
ALU 125	115	40 (30,35)	3+3	6150415E21140	380,00	
ALU 125	136	40 (30,35)	3+3	6150415E21340	437,60	
ALU 125	158	40 (30,35)	3+3	6150415E21540	484,00	
ALU 125	180	40 (30,35)	3+3	6150415E21840	528,80	
ALU 125	201	40 (30,35)	3+3	6150415E22040	609,60	
ALU 125	223	40 (30,35)	3+3	6150415E22240	647,20	
ATYP	80~180	80~280	2+2~4+4	cena na vyžiadanie		

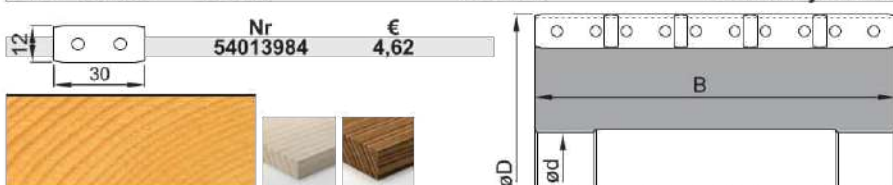

Špirálové AL hobľovacie valce s jednoduchou výmenou a nastavovaním žiletiek. Obrobeneý povrch je konštrukčnej kvality. Nízkoohlučné.



T208 ŠPIRÁLOVÉ TANGENCIÁLNE VALCE						HW
ø D	B	ø d	Z	Nr	€	
125	98	40	2+2	235T208MBABB0AX	534,00	
125	128	40	2+2	235T208MBCBB0AX	600,00	
125	180	40	2+2	235T208MBDBB0AX	818,00	
125	232	40	2+2	235T208MECAA0AX	981,00	
ATYP	80~180	60~280	2+2~4+4	cena na vyžiadanie		

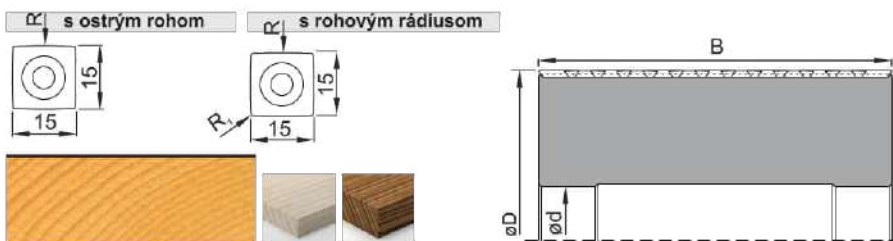

Nástroj je vhodný pre veľký úber triesky, pri zvýšených nárokoch na kvalitu obrábania. Na zákazku vyrábame rôzne rozmery valcov. Nie je vhodný ako dokončovaci nástroj.



F200 MULTIŠPIRÁLOVÉ VALCE						HW
ø D	B	ø d	Z	Nr	€	
125	80	40	12	235F200M1250812	497,00	
125	100	40	12	235F200M1251012	550,00	
125	120	40	12	235F200M1251212	602,00	
125	160	40	12	235F200M1251612	706,00	
125	180	40	12	235F200M1251812	759,00	
125	230	40	12	235F200M1252312	995,00	
ATYP	80~200	60~350	6~16	cena na vyžiadanie		

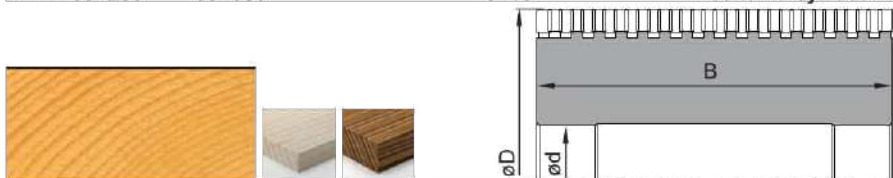

Nástroj s extrémne nízkym rezným odporom predučuje okrem iného, aj na veľké úbery materiálu tvrdých drevín. Mimoriadne kvalitný obrobeneý povrch, dlhá životnosť. Na zákazku dodávame ľubovoľné rozmery špirálových hláv. Pre možnosť ešte znížiť rezný odpor je možné nástroj dodať s deličom triesky. Pre ručný posuv na kopirovacích strojoch môže mať nástroj obmedzovač triesky.



01-25 ŠPÁROVACIE ŽILETKOVÉ FRÉZY HW

TYP	ø D	B	ø d	Z	Nr	€
ALU B	130	50	30	2	7018130050030A2	321,00
OCEĽ C	140	60	40 (30,35)	2	615K428E00030	277,00

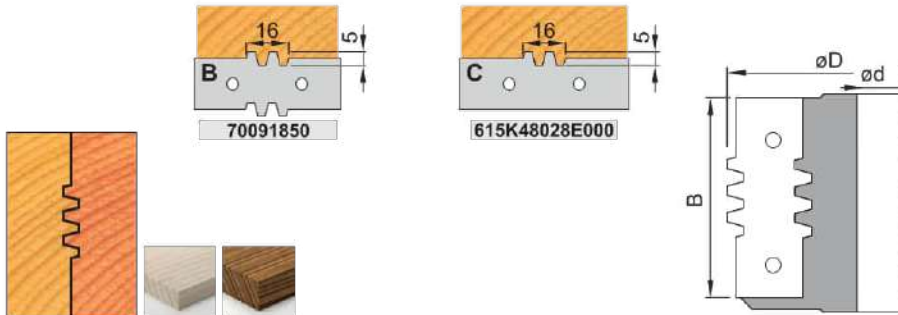

Špárovacie frézy jednoduchšej dvojzubovej konštrukcie. Vyhotovení s AL nosičom určené pre malé spodné frézočky.



8355 ŠPÁROVACIE FRÉZY HW

ø D	B	A	ø d	Z	Nr	€
125	50	16	30 (40)	3	53071110	288,00
125	60	24	30 (40)	3	53079110	346,00



Špárovacie frézy s navareným plátkom určené pre spodné frézočky a štvorstranné frézočky. Dostatočne veľká zubová medzera umožňuje aj väčšie úbery materiálu a zabezpečuje dobrý odvod triesky.



K428F ŠPÁROVACIE OKNÁRSKE FRÉZY HW

ø D	B	ø d	Z	Nr	€
140	80	30 (40,50)	3	615K428F00030	533,00

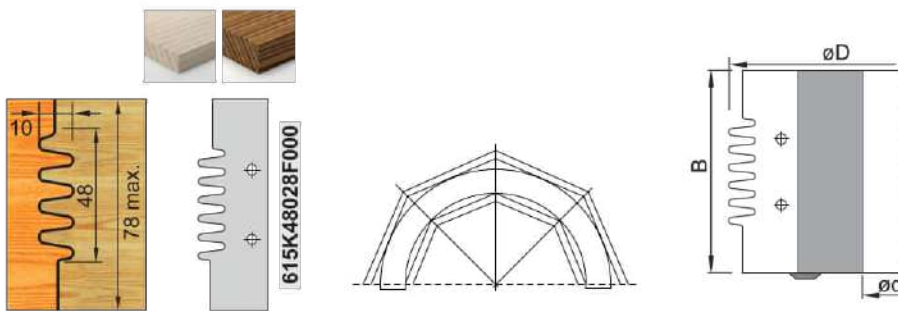

Nástroj s fixným rozmerom na spájanie segmentov pri výrobe oblúčkových okien a dverí.



K428GH NASTAVITELNÉ ŠPÁROVACIE OKNÁRSKE FRÉZY HW

ø D	B	ø d	Z	Nr	€
150	130	30 (40,50)	2	615K428GH0030	1223,00

na objednávku

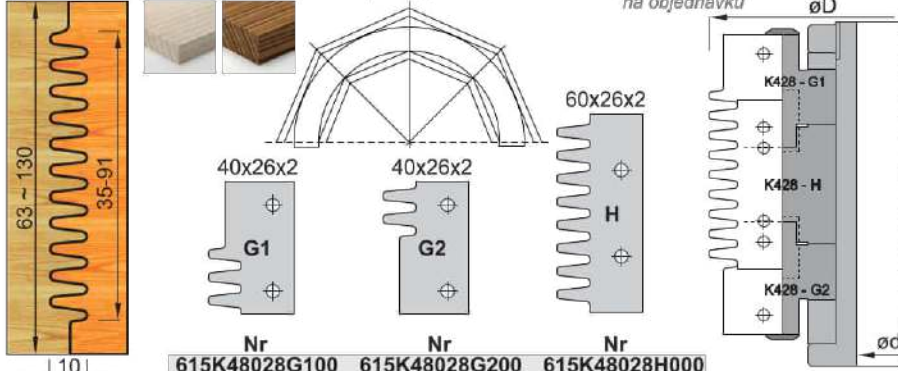

Nástroj s nastaviteľnou šírkou (63-130mm) na spájanie segmentov pri výrobe oblúčkových okien a dverí.





YH156
MINIZINKOVÉ FRÉZY LIGHT HW

$\varnothing D$	B	t	$\varnothing d$	Z	Nr	€
125	60	10	30	2	112SYH156AAM	216,70

Nástroj na pozdĺžne nadpájanie pre nenáročné remeselné použitie. Tvar spoja nie je určený na pevnostné namáhanie vyžadovaným príslušnou normou.



FJ160
MONOMINIZINK HW

$\varnothing D$	B	t	$\varnothing d$	Z	Nr	€
160	3,8	10	50 (70)	4	228FJ1603850.4	45,20
160	10	10	50 (70)	4	228FJ1601050.4	70,80

Priemyselný typ nástroja pre zinkovacie stroje s roztriekavačom. Naskladaním jednotlivých kotúčových fréz je možné dosiahnuť požadovanú výšku obrábaného materiálu. S použitím krajových fréz je možné vytvoriť uravretý zink.



147
MINIZINKOVÉ FRÉZY HW

$\varnothing D$	B	t	$\varnothing d$	Z	Nr	€
140	110	10	30 (40)	4	290147	830,00

Nástroj s otvoreným tvarom spoja a plným profilom 10/10.



147D
NASTAVITELNÉ MINIZINK FRÉZY HW

$\varnothing D$	B	t	$\varnothing d$	Z	Nr	€
140	10 - 90	10	30	4+4	290147D	1275,00

Staviteľný nástroj s uzatvoreným tvarom spoja a plným profilom 10/10

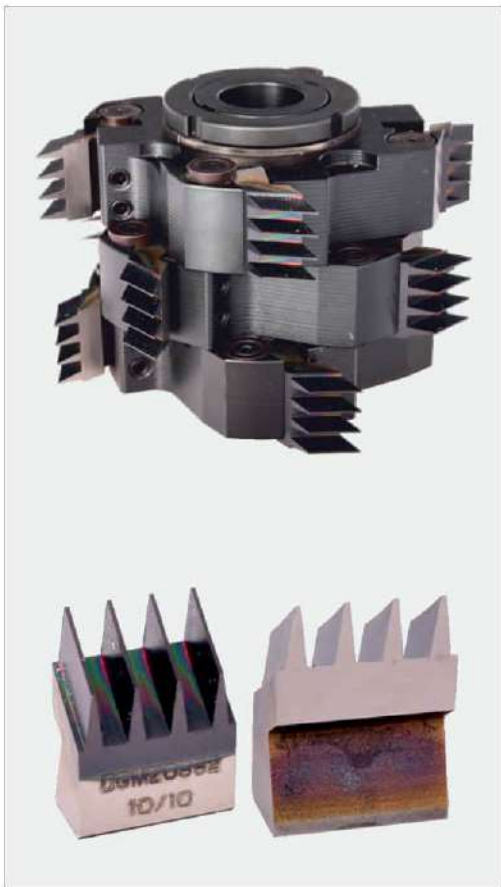

TG05F SYSTÉM MINIZINK HSC, HW

$\varnothing D$	B	$\varnothing d$	Z	Nr	€
160	30,4	40 (50)	4	112STG05FC03	140,40
250	30,4	40 (60)	6	112STG05FC04	209,00

na objednávku

$\varnothing D$	B	$\varnothing d$	Z	Nr	€
170	30,4	40 (50)	4	112STG05FC05	199,00
250	37,2	40 (50)	6	112STG05FC06	289,00

na objednávku

$\varnothing D$	B	$\varnothing d$	Z	Nr	€
180	37,2	40 (50)	4	112STG05FC07	234,00
260	37,2	40 (50)	6	112STG05FC08	332,00

na objednávku

$\varnothing D$	B	t	Rozteč	Nr	€
HS	28,4	10/10	3,8	112SCGMZ0S62	72,00
HW	28,4	10/10	3,8	112SCGMZ0M62	200,00
HS	28,4	10/11	3,8	112SCGMZ0S63	72,00
HW	28,4	10/11	3,8	112SCGMZ0M63	200,00
HS	28,4	15/15	3,8	112SCGMZ0S64	112,50
HS	28,4	15/16,5	3,8	112SCGMZ0S65	112,50
HS	32,5	20/20	6,2	112SCGMZ0S66	130,50
HS	32,5	20/22	6,2	112SCGMZ0S67	130,50



Široký sortiment nosičov a nožov vysokej priemyselnej kvality. Výsledná cena je daná použitým nosičom a vybraným typom a počtom nožov. HS nože sú štandardne povlakované pre dlhšiu životnosť.



TG06FC SYSTÉM MINIZINK - JOINTEX HSC

$\varnothing D$	B	$\varnothing d$	Z	Nr	€
160	30,4	40 (50)	4	112STG06FC03	219,00
160	30,4	40 (50)	6	112STG06FC13	265,00
250	30,4	40 (50,60)	6	112STG06FC04	312,00
250	30,4	40 (50,60)	8	112STG06FC14	359,00
250	30,4	40 (50,60)	10	112STG06FC18	414,00
250	30,4	40 (50,60)	12	112STG06FC28	476,00
250	30,4	40 (50,60)	14	112STG06FC44	538,00
250	30,4	40 (50,60)	16	112STG06FC54	593,00

Nož 10/11 112SCGMZ0S63 72,00

Vysoko výkonný systém frézovacích nástrojov. Unikátny systém samocentrických nožov robí výmenu nožov ešte jednoduchšiu a rýchlejšiu. Výsledná cena je daná použitým nosičom a počtom nožov. HS nože sú štandardne povlakované pre dlhšiu životnosť.



TECHNICKÉ INFORMÁCIE

OTVORENÝ ZINK

Ozubený profil je frézovaný v celej výške materiálu. Využíva sa na konštrukčné prvky v stavebnom stolárstve, ako napr. KVH hrany.

ZINK VYTVORENÝ FRÉZOVANÍM CELÉHO PROFILU t= 10/10 ; 15/15; 20/20

Výroba spojov na jednoduchších strojoch, kde je iba frézovací hriadeľ. Tesnosť a presnosť spoja je daná iba kvalitou nástroja.

UZATVORENÝ ZINK

Ozubený profil je umiestnený v strednej časti frézovaného materiálu. Krajové časti sú frézované natupo, aby spoj na pohľadových plochách nepôsobil rušivo.

ZINK VYTVORENÝ ZAKRÁTENÍM ROZTRIESKOVACOM NA DĺŽKU, A FRÉZOVANÍM ČIASTOČNÉHO PROFILU t= 10/11 ; 15/16,5 ; 20/22.

Priemyselná výroba spojov. Zoradením roztrieskavacej a frézovacej jednotky je možné regulovať tesnosť spoja v jeho päte. Toto riešenie zároveň menej zaťažuje frézovací nástroj, nakoľko konce spoja sú obrábané roztrieskavačom. Týmto sa predlžuje životnosť frézovacieho nástroja oproti predošlému systému.

OBSAH



170 HOBY PERO-DRÁŽKA FRÉZY			HW	
ø D	B	ø d	Nr	€
120	10-22	30	615K1700030HW	280,00

Remeselná sada fréz pre štyri druhy profilov pero-drážky.



YS113AZM PERO-DRÁŽKA LIGHT			HW	
ø D	B	ø d	Nr	€
140	30	2	112SYS113AZM	715,00

Sada pozostávajúca zo 4 nástrojov, kombináciou ktorých je možné dosiahnuť 3 typy profilov. Nástroje sú určené pre spodné frézovačky a sú vhodné aj pre ručný posuv.

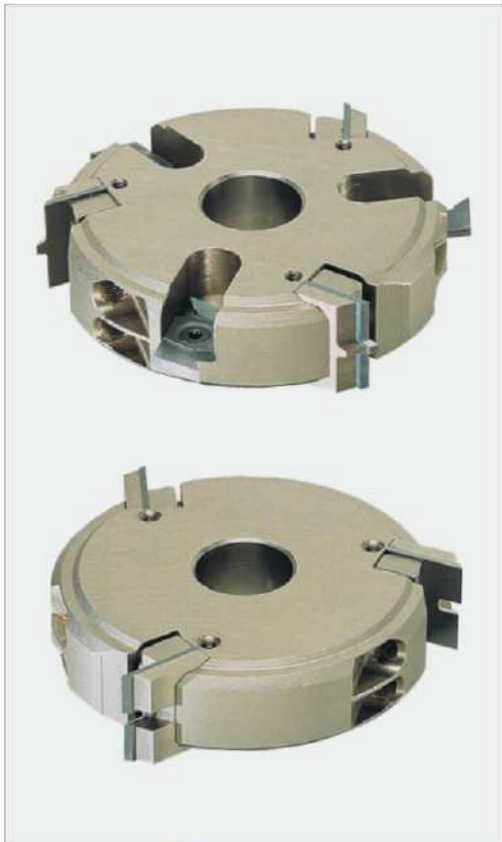

425 PERO-DRÁŽKA MULTI			HW		
Nosič	ø D _{max}	B	ø d	Nr	€
L	144	30	40	6150400F30040	145,00
P	139	30	40	6150400N31040	254,00

nôž	Nr	€	nôž	Nr	€
opomý nôž	61504802551LH	38,-	opomý nôž	61504802551RH	38,-
opomý nôž	61504802552LH	17,-	opomý nôž	61504802552RH	17,-
nôž	61504802561LH	38,-	nôž	61504802561RH	38,-
opomý nôž	61504802562LH	17,-	opomý nôž	61504802562RH	17,-
nôž	61504802571LH	38,-	nôž	61504802571RH	38,-
opomý nôž	61504802572LH	17,-	opomý nôž	61504802572RH	17,-
nôž	61504802581LH	38,-	nôž	61504802581RH	38,-
opomý nôž	61504802582LH	17,-	opomý nôž	61504802582RH	17,-

Univerzálny systém fréz pre profily typu pero-drážka. Nosiče sa osádzajú vybraným typom nožov.



5022		PERO-DRÁŽKA FRÉZY			HW	
TYP	ø D	B	ø d	Z	Nr SET	€
1	160	12-50	40	4	1115522P2D1	980,00
3	135	13-28	40	4	1115021P3D3	960,07
3	179	13-28	40	4	1115022P3D3	1232,00
5	135	13-35	40	4	1115021P5D5	679,44
5	180	13-35	40	4	1115522P5D5	1005,64
8	172	13-32	40	4	1115022P8D8	821,48

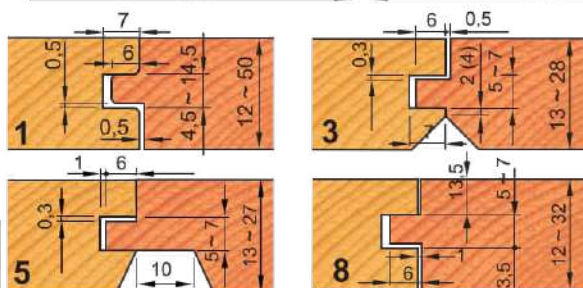
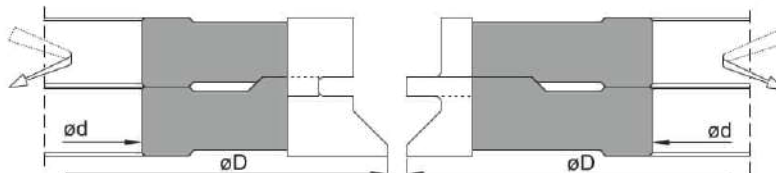

Štandardné sady produkčných nástrojov do štvorstranných frézovačiek. Na zákazku dodávame sady podľa konkrétneho zadania.



T330		PERO-DRÁŽKA INDUSTRY			HW	
Fréza č.	ø D	B	ø d	Z	Nr	€
1	160	20	40	4	235T330M16020AA	295,00
2	147	12	40	4	235T330M14712AA	216,00
3	159	20	40	4	235T330M15920AA	295,00
4	175	25	40	4	235T330M17525AA	302,00
5	175	25	40	4	235T330M17525BA	302,00
6	174	12	40	4	235T330M17412AA	244,00
7	174	12	40	4	235T330M17412BA	244,00
8	160	20	40	4	235T330M16020BA	295,00
9	195	15	40	4	235T330M19515AA	355,00
10	175	15	40	4	235T330M17515AA	378,00
11	169	20	40	4	235T330M16920AA	304,00
12	184	25	40	4	235T330M18425AA	304,00
13	184	18,5	40	4	235T330M18418AA	336,00

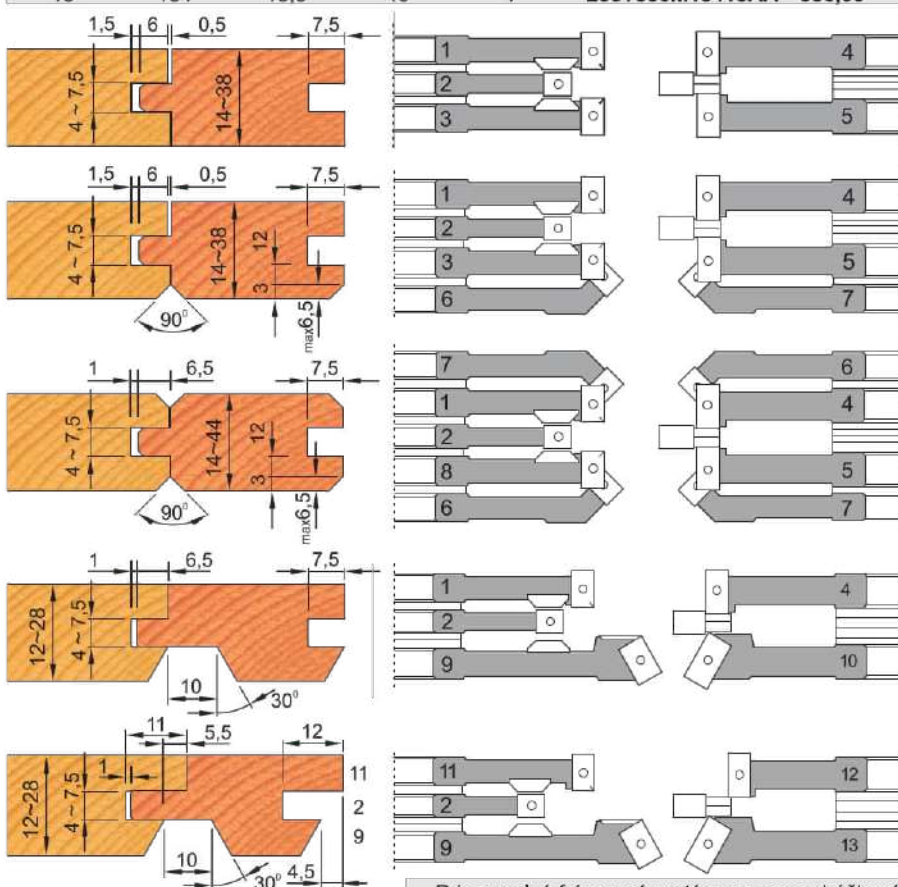

Priemyselný frézovací systém pre pero-drážkové konštrukcie. Nástroje sú osadené štandardnými žiletkami pre čo najmenšie náklady na bežný meter opracovania. Zostavením rôznych kombinácií nástrojov je možné doceliť široké spektrum profilov.





050 FRÉZY NA MADLÁ				HW		
$\varnothing D$	B	$\varnothing d$	Z	Nr	€	
160	70	30	2	290164C	398,00	

Pre inšpiráciu žiadajte samostatný katalógový list profilov madiel vyrábaných na zákazku.



YH133AAM FRÉZA NA UHLOVÝ SPOJ LIGHT				HW		
ALU $\varnothing D$	B	$\varnothing d$	Z	Nr	€	
140	32	30	2	112SYH133AAM	181,50	

Možnosť úpravy upínacieho otvoru na 40mm.



K428-T FRÉZA NA UHLOVÝ SPOJ				HW		
$\varnothing D$	B	$\varnothing d$	Z	Nr	€	
180	56	30	2	615K428T00030	463,00	
				615K48028T000	51,80	

Možnosť objednať aj s upínacím otvorom 35,40 a 50mm.



14.120 MULTI FRÉZY				HW		
$\varnothing D$	B	$\varnothing d$	Z	Nr	€	
120	40	30	2	7014120040030A	228,00	

Univerzálny nástroj pre kombinovanie rôznych profilov viacnásobným prefrezovaním.



14.180 PROFILOVÉ FRÉZY NA DVIERKA				HW		
ALU $\varnothing D$	$\varnothing d$	Z	Nr	€		
180	30 (40 ; 50)	2	7014180040230A	205,00		

Univerzálna dverková fréza, v základe osadená profilom 1.



93747 HW

FRÉZY NA ZÁSUVKOVÉ MADLÁ

ø D	B	ø d	Z	Nr	€
160	20	30	2	61593747	296,50

STANDARD

PROFILA3

Samostatný nástroj na frézovanie úchytkovej časti madlového profilu.



09913 HW

SADA FRÉZ NA ZÁSUVKOVÉ MADLÁ

ø D	B	ø d	Z	Nr	€
160	30	30	2+2	235GRSPTM049510	487,00

A

C

B

D

X

Y

Nástrojový set na frézovanie madlových profilov zásuviek a dveriek. V základe bude nástroj osadený profilom podľa vlastného výberu.

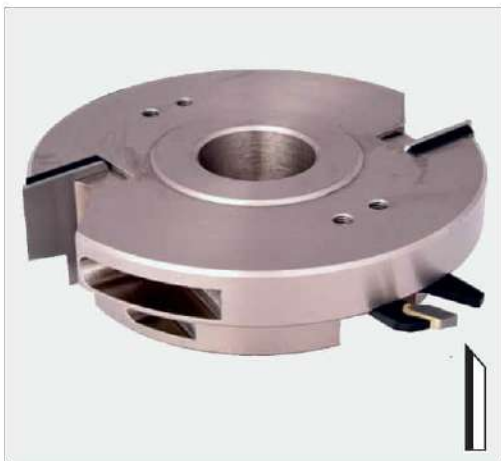

FRÉZY NA AL ÚCHYTKY

23721 HW

ø D	B	ø d	Z	Nr	€
120	30	30	2+2	280TSP152SD01	282,00
120	30	30	2+2	280TSP152SD02	282,00
120	30	30	2+2	280TSP152SD03	282,00

Remeselný nástroj pre frézovanie tvarových drážok pre hliníkové úchytky. V prípade potreby je možné vyrobiť profilové nože podľa aktuálnej požiadavky na zákazku.

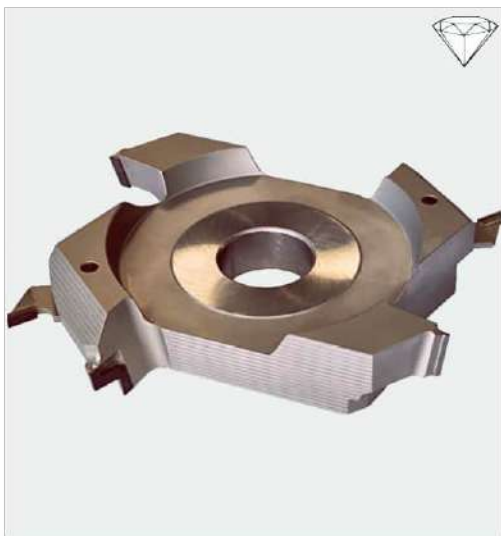

237DP DIA

Profil	ø D	B	ø d	Z	Nr	€
Profil A	163,8	24	30	2+2+2	235FS03DS2372101	435,50
Profil B	166	24	30	2+2+2	235FS03DS2372102	435,50
Profil C	166	24	30	2+2+2	235FS03DS2372103	435,50

Profil A

Profil B

Profil C

Priemyselný nástroj pre frézovanie tvarových drážok pre hliníkové úchytky. Pozitívno-negatívne uloženie zubov znižuje merný rezný odpor a zvyšuje životnosť nástroja.





TD21
VÝPLŇOVÉ FRÉZY HOBBY LIGHT HW

	ø D	B	ø d	Z	Nr	€
ALU	140	18	30	2	280TD21MHA3	144,00

10,5
6,7
12,5°
40

nůž 280CT21MAA3 40,00

10,5
6,56
R3
R27
R26
40

10,5
6,56
R25
R25
40

10,5
R48,5
40

nůž 280CT21MCA3 40,00 nůž 280CT21MDA3 40,00 nůž 280CT21MEA3 40,00

Ekonomický nástroj osaditeľný 3mm hrubými žiletkami umožňujúci mnohonásobné ostrenie. Pri objednávke je potrebné špecifikovať požadovaný profil.



FS030
VÝPLŇOVÉ FRÉZY NA MDF DVIERKA DIA

Profil	ø D	B	ø d	Z	Nr	€
A	170	24.5	30	2	235FS03DS058886	398,00
B	170	24.5	30	2	235FS03DS058887	398,00
C	170	24.5	30	2	235FS03DS058888	398,00

6
R125
17
55

Profil A

6
2x45°
25
55

Profil B

6
2
R60
R75
17
55

Profil C

Frézovacie nástroje na MFD výplne určené na následné vákuové lisovanie, prípadne striekanie.



YS149
VÝPLŇOVÉ FRÉZY MULTIPROFIL HW

	ø D	B	ø d	Z	Nr	€
ALU	180	23	30	2	112SYS149AZM	216,50

max 18
5
R5
R5
R40
R60
42
54

nůž 606Z055831R

max 18
5
R5
R6
R40
R60
49
54

nůž 606Z055832R

max 18
5
R6,5
R8,5
R40
R60
49
54

nůž 606Z055833R

max 17
3
R5
R5
49
54

nůž 606Z055834R

max 17
3
R6,5
R8,5
49
54

nůž 606Z055835R

nůž 606Z055836R

Multiprofilová fréza osaditeľná viacerými profilmi. Vďaka svojmu priemeru a profilovým zónam je vhodná na výrobu výplní pre nábytkové dvere a interiérové dvere.



14.200
VÝPLŇOVÉ FRÉZY NA DVIERKA A DVERE HW

	ø D	B	ø d	Z	Nr	€
ALU	200	35	30	2+2	7011200035130A	299,90

25
R6
R20
63

B
øD
ød

Hliníkové telo nástroja dovoľuje frézovanie hlbokého profilu pri viacnásobnom prechode aj na remeselnej triede frézovačiek.



K427 - 1/2
VÝPLŇOVÉ FRÉZY UNIVERZÁL HW

	ø D	B	t	ø d	Z	Nr	€
R	200	20	57	30	2+2	615K427010030	361,00
L	200	20	57	30	2+2	615K427020030	361,00

Priemyselný nástroj dodávaný v sade obsahujúci žiletky pre všetky uvedené kombinácie profilov. Najlepší pomer ceny/výkon.



K427 - 3/4
VÝPLŇOVÉ FRÉZY VLNOVKA HW

	ø D	B	t	ø d	Z	Nr	€
R	200	20	56	30	2+2	615K427030030	342,00
L	200	20	56	30	2+2	615K427040030	342,00

Priemyselný nástroj s obľúbeným vlnkovým profilom na interiérové a exteriérové dvere.



TD55MD
VÝPLŇOVÉ FRÉZY PRE HLBOKÉ PROFILOVANIE HW

	ø D	ø d	Z	Nr	€
R	210	30	2+2	280TD55MS1	450,00
L	210	30	2+2	280TD55MD1	450,00
R	210	30	2+2	280TD55MS2	450,00
L	210	30	2+2	280TD55MD2	450,00

Frézovacie nástroje určené pre hlboké frézovanie exteriérových výplní dverí.



138
VÝPLŇOVÉ FRÉZY TROJBRITÉ HW

ø D	B	t	ø d	Z	Nr	€
220	65	20	30	3+3	290C1DX	545,00
220	65	20	30	3+3	290C1SX	545,00
220	65	20	30	3+3	290C2DX	545,00
220	65	20	30	3+3	290C2SX	545,00

Výkonné nástroje určené pre výplne exteriérových dverí s vynikajúcim odvodom triesky.





925 TVAROVÉ FRÉZY NA DVIERKA HW

$\varnothing D$	B	$\varnothing d$	Z	Nr	€
160	12,5	30	2	1118152R160	196,50

drážkovacia fréza vid. strana 1.1

Tvarovú frézu je možné kombinovať podľa požadovaného tvaru s drážkovacími frézami zo strany 1.1.



157 SADA FRÉZ NA DVIERKA HW

$\varnothing D$	B	$\varnothing d$	Z	Nr	€
140	36	30	2+2	290157A	326,00

SKLO

Frézovacia sada umožňujúca výrobu dvierok so vsadenou, alebo lištovanou výplňou.



12.120 KONTRA FRÉZY NA DVIERKA HW

$\varnothing D$	B	$\varnothing d$	Z	Nr	€
120	40	30	2	7012120040030A	257,00

nôž 7009.1201 nôž 7009.1202
nôž 7009.1203 nôž 7009.1204

Multiprofilová ALU fréza na dverka so vsadenou výplňou. Dodáva sa s osadeným profilom 7009.1203.



YS101AZM SADA FRÉZ NA RÁM A VÝPLNE DVIEROK HW

Nástroj	$\varnothing D$	B	$\varnothing d$	Z	Nr SADA	€
A	120	40	30	2	112SYS101AZM	327,00
B	183	30	30	2+2		

nôž 606Z055.843.R nôž 606Z055.844.R
nôž 606Z055.845.R nôž 606Z055.846.R

Cenovo výhodná sada ALU nástrojov na kompletnú výrobu dvierok so vsadenou výplňou. Profílovací nástroj sa dodáva osadený profilom 606Z055.543R.



K426-P
MULTI FRÉZY NA DVIERKA

$\varnothing D$	B	$\varnothing d$	Z	Nr	€
160	40	30	2+2	615K426P00030	331,00

Združený nástroj na frézovanie dvierok aj ich výplní. Oceľový nosič.



K426-1
SADA NA RÁM A VÝPLNE DVIEROK

$\varnothing D$	B	$\varnothing d$	Nr SET	€
160	30	30	615K426010030	830,00

Nástrojová sada na kompletnú výrobu dvierok-rámu aj výplne. Dodávaná so štyrmi druhmi profilov a ložiskovou sadou aj na výrobu tvarových dvierok. Umožňuje výrobu dvierok s pevnou aj lištovanou výplňou.



K426-2
UNIVERZÁLNA SADA FRÉZ NA DVIERKA

$\varnothing D$	$\varnothing d$	Z	Nr SET	€
160	30	2	615K426020030	955,00

Nástrojová sada na kompletnú výrobu rámovej konštrukcie dvierok. Dodávaná s tromi druhmi profilov a ložiskovou sadou aj na výrobu tvarových dvierok. Umožňuje výrobu dvierok s drážkou pre pevnú výplň, a polodrážkou pre výplň lištovanú.



K426-6
UNIVERZÁLNA SADA FRÉZ NA DVIERE A DVIERKA

$\varnothing D$	$\varnothing d$	Z	Nr SET	€
180	30	2	615K42606P030	1440,00

Priemyselná nástrojová sada na puzdrách na kompletnú výrobu rámovej konštrukcie dvierok s drážkou, alebo polodrážkou. Sadu je tiež možné použiť na výrobu interiérových lištovaných dverí.



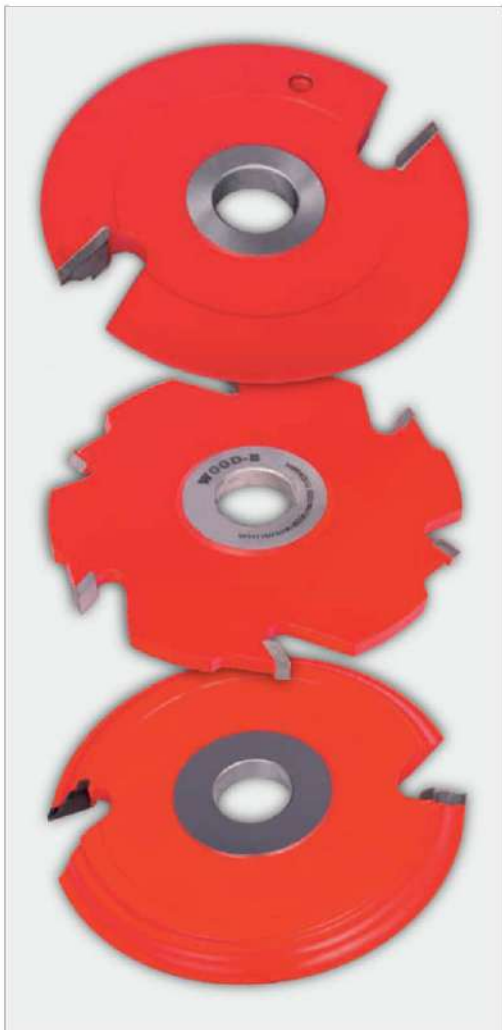

**815
FRÉZY NA DVERE KLASIK**

HW

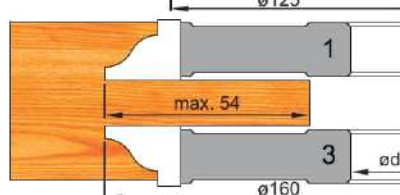
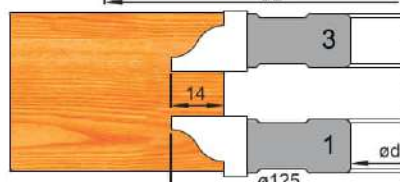
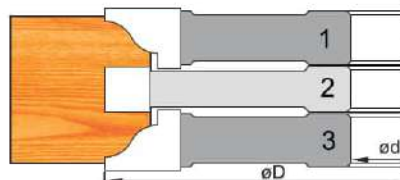
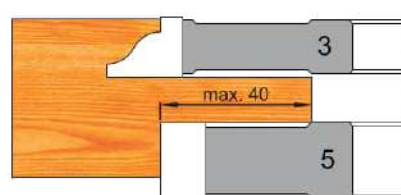
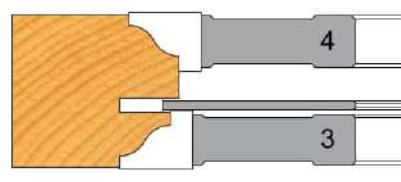
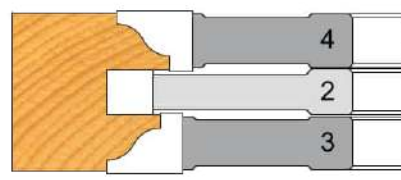
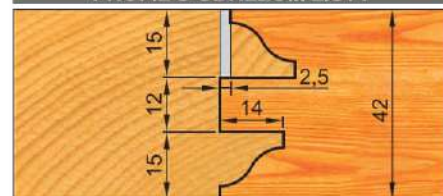

TYP	ø D	B	ø d	Z	Nr	€
1	125	16	30	2	1118151R125	163,00
3	125	16	30	2	1118151L125	163,00
1	160	16	30	2	1118151R160	196,50
3	160	16	30	2	1118151L160	196,50
2	Podľa potreby vyberte rozmer na strane 1.1					
4	155	16	30	2	1118151R155	196,50
5	132	20	30	4	1118151D132	163,50

PROFIL BEZ ODREZU LIŠTY

PROFIL S ODREZOM LIŠTY

**815R
FRÉZY NA DVERE VILLAGE**

HW

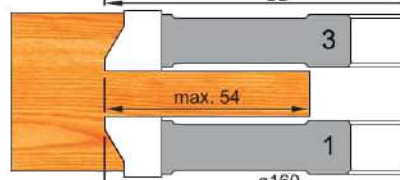
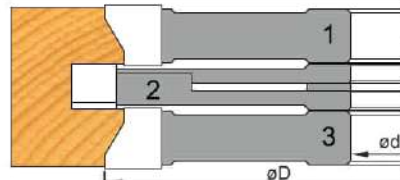
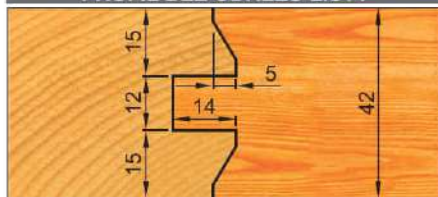
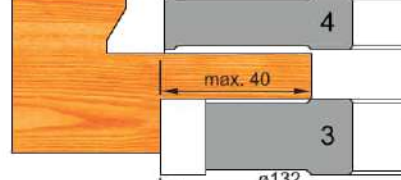
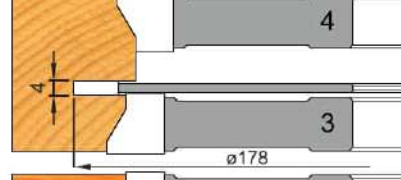
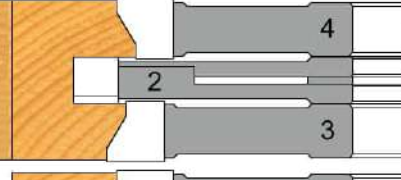
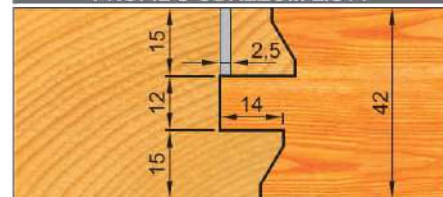



TYP	ø D	B	ø d	Z	Nr	€
1	160	16	30	2	111815RR160	196,50
2	178	10~19	30	2+2	111815S178	225,00
3	160	16	30	2	111815RL160	196,50
4	155	16	30	2	111815RR155	196,50
5	132	20	30	4	1118151D132	163,50
6	178	4	30	16	111815D178	225,00

PROFIL BEZ ODREZU LIŠTY

PROFIL S ODREZOM LIŠTY

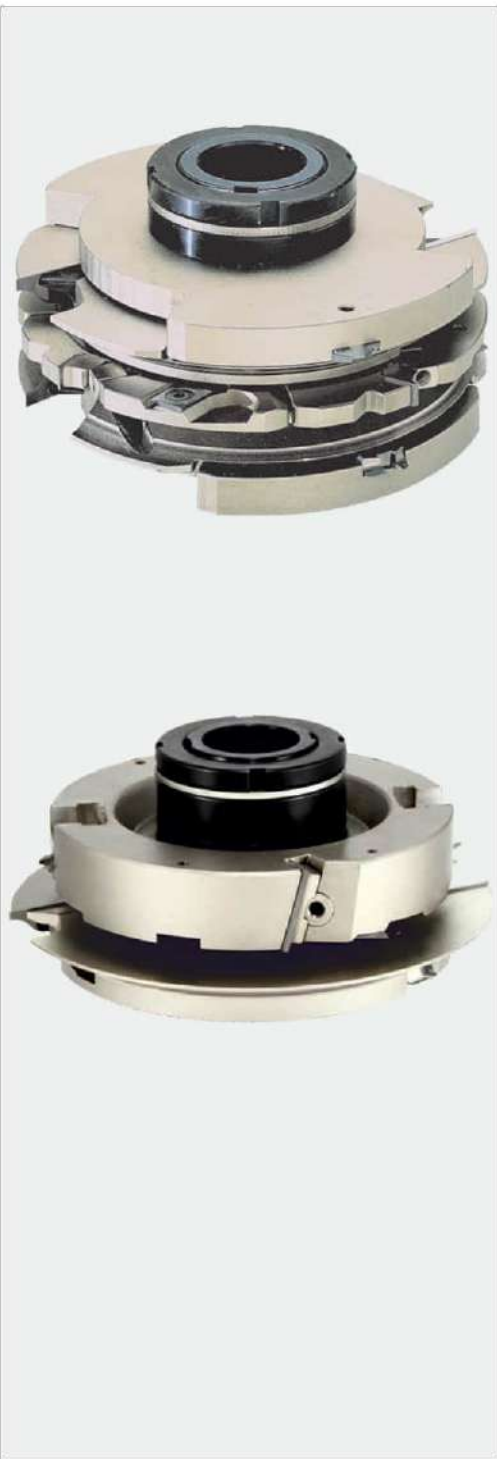
PILOVÝ KOTUČ NA ODREZANIE LIŠTY

ø D	B	ø d	Z	Nr	€
250	2,5	30	48WZ	280LU1H0700	51,20

Tradičné nástroje s navarenými HM plátkami. Ich kombináciou s drážkovacími fréзами zo strany 1.1 je možné dosiahnuť požadovanú výslednú hrúbku dverového profilu. Klasický tvar vlnky je doplnený o nový profil vhodný pre rekonštrukcie stavieb z medzivojnového obdobia.



K411 **FRÉZY NA INTERIÉROVÉ DVERE - PROFI** HW 

ZÁKLADNÁ SADA S ODREZOM LIŠTY

ø D	ø d	Z	Nr	€
160	30	2	615K4110430R3	1 768,00

ROZŠÍRENIE NA TENKÚ VÝPLŇ

ø D	ø d	Z	Nr	€
160	30	8	61595100	120,00

ROZŠÍRENIE - PROFIL BEZ ODREZU LIŠTY

ø D	ø d	Z	Nr	€
160	30	2	615K4112R	535,00

PÍLOVÝ KOTUČ NA ODREZANIE ZASKLIEVACEJ LIŠTY

ø D	B	ø d	Z	Nr	€
200	2	30	16 LWZ	6150316203016	38,40

Systém nástrojov na výrobu interiérových dverí s krátkym čapom, alebo kolíkovým spojom. V základe je sada dodávaná na výrobu dverí s odrezom lišty pre drevenú výplň s profilom 01. Túto je možné doplniť o frézu na tenkú lištovanú výplň. Rovnako je možné sadu rozšíriť aj o nástroje pre výrobu dverí s plnou drevenou výplňou.



TP42 **UNIVERZÁLNE FRÉZY NA DVERE** HW 

ø D	ø d	Z	Nr	€
176	35 (50)	2+2	280TP42MAB3	322,00

Univerzálny nástroj, štandardne osadený profilom CA3 je vhodný aj pre remeselné spodné frézy. Pri výrobe dverového profilu sa vyžaduje dvojnásobné prefrezovanie.



YS112AZM HW   

SADA ŽILETKOVÝCH FRÉZ NA DVERE

	ø D	ø d	Z	Nr SET	€
ALU	132	30	2+2	112SYS112AZM	468,00

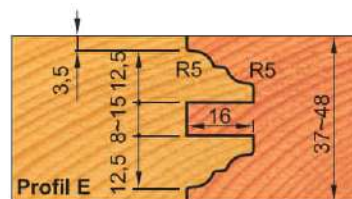
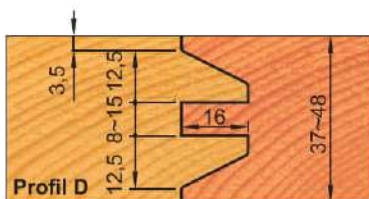
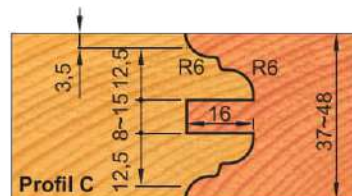
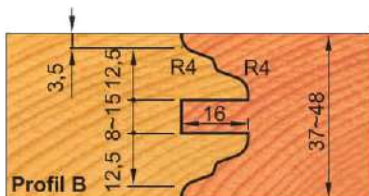
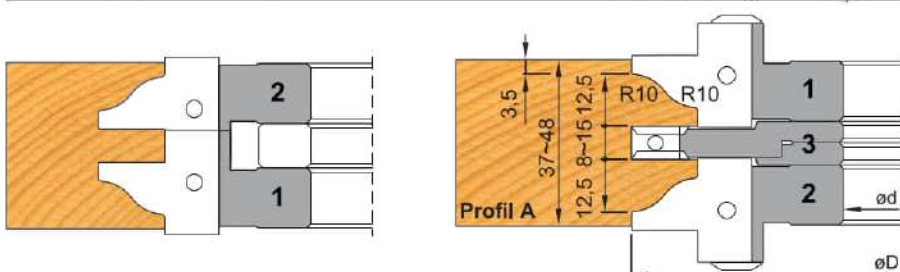

Sada pozostáva z dvoch profilovacích nástrojov a staviteľnej drážkovacej frézy. V základe je osadená profilom A. Určená pre dvere s pevnou drevenou výplňou.



NDK HW   

SADA FRÉZ NA RÁMOVÚ KONŠTRUKCIU DVERÍ

	ø D	ø d	Z	Nr	€
ALU	140	30	2+2	235GRPTM060053	542,00

sada nožov na priznaný spoj 45° 235C044R45 29,80/1ks

sada nožov na priznaný spoj R=1,5 235C044R3 29,80/1ks

sada nožov na priznaný spoj R=3 235C044R15 29,80/1ks

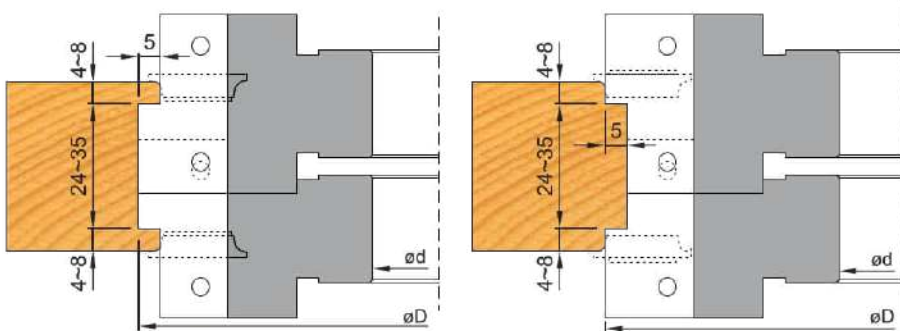

PRÍKLADY POUŽITIA:

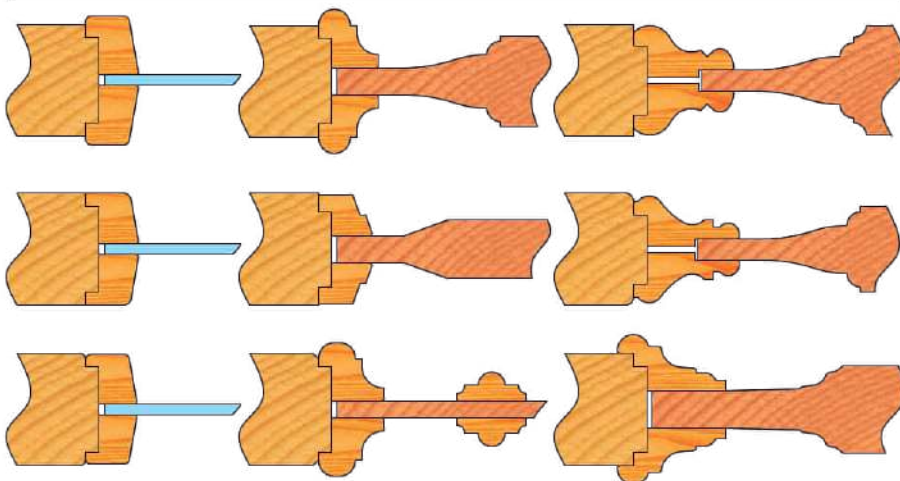

Sada nástrojov na rámovú konštrukciu dverí. Spoj typu kontra-rekontra je možné doplniť o priznaný spoj požadovaného rádiusu. Typom spoja a tvarovou lištou je následne možné vyrobiť dvere požadovaného designu, od historických replík až po moderný minimalistický štýl.

421 FRÉZY NA DVERE S DLHÝM ČAPOM HW

ø D	ø d	Z	Nr	€
160	30 (40,50)	2	615K4211530R3	1 239,00
320	30 (40,50)	4	615K422230R3	1 010,00

osadené v nástroji R3 opcia 45° R1.5

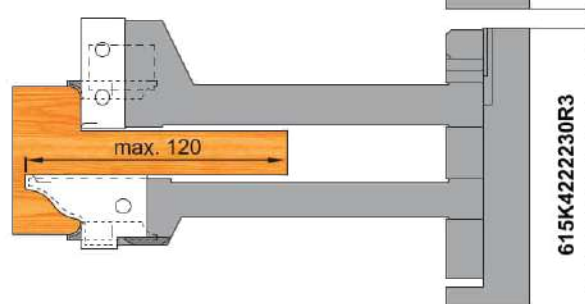
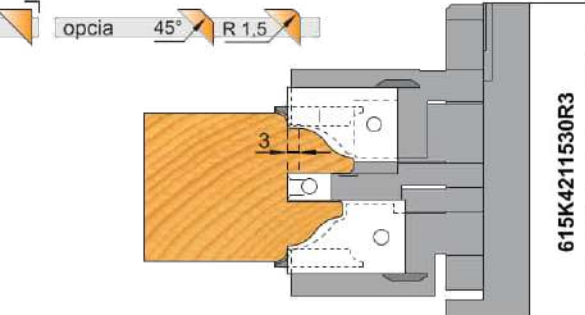
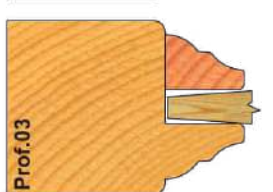
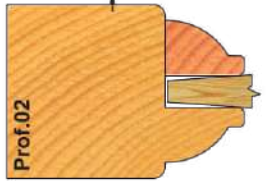
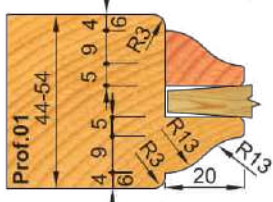

Priemyselná žiletková sada na interiérové dvere s dlhým, alebo krátkym čapom. Bez priznaného spoja, alebo s priznaným spojom (v základe R3). S vyrezávaním sklo-lišty, nastaviteľnou drážkou pre výplň. Možnosť osadenia troch druhov profilov (v základe profil 01).

ROZŠÍRENIE NA TENKÚ VÝPLŇ

ø D	B	ø d	Z	Nr	€
166	4	60	8FZ	615A5234	135,00

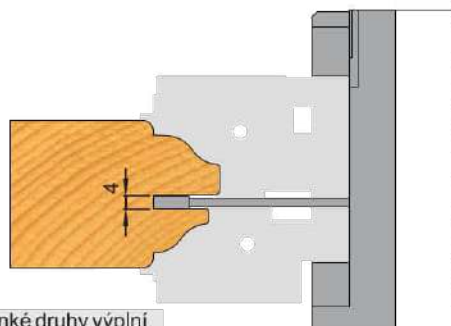

Drážkovacia fréza s navarenými plátkami pre tenké druhy výplní.

ROZŠÍRENIE - PROFIL BEZ ODREZU LIŠTY

ø D	ø d	Z	Nr	€
166	60 (30,40,50)	2	615K421V060R3	361,60
320	60 (30,40,50)	4	615K422P060R3	536,00

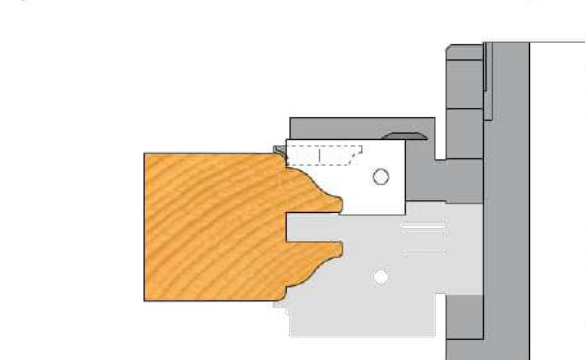
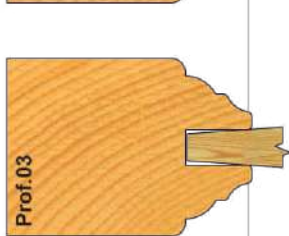
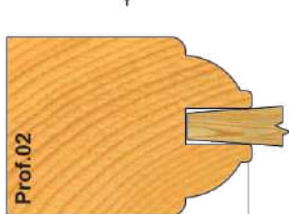
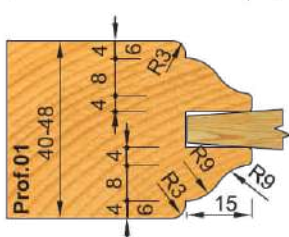

Dodatkové žiletkové nástroje na rozšírenie sady pre frézovanie dverového profilu bez odrezu sklolišty.





988R	FALCOVACIE FRÉZY S VNÚTORNÝM RÁDIUSOM		HW				
$\varnothing D$	$\varnothing d$	Z	Nr SET	€			
125	30	4+2	530988R1R3	350,00			

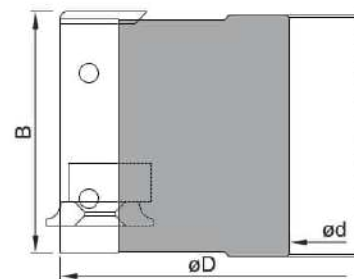
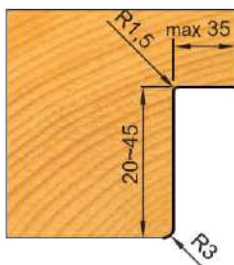

K423-2	FALCOVACIA SADA NA DVERE - ROVNÁ		HW				
t	$\varnothing D$	$\varnothing d$	Z	Nr SET	€		
13	156	30(40,50)	2+2	615K4230230R3	674,00		
15	156	30(40,50)	2+2	61593013	761,50		

osadené v nástroji R 3 opcia 45° R 1,5

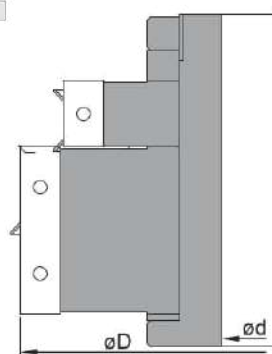
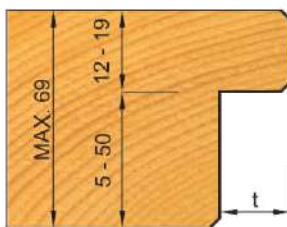

K423-6	FALCOVACIA SADA NA DVERE - ŠIKMÁ		HW				
t	$\varnothing D$	$\varnothing d$	Z	Nr SET	€		
11	156	30(40,50)	2+2	615K4230630R3	742,00		
15	156	30(40,50)	2+2	61584717	826,50		

osadené v nástroji R 3 opcia 45° R 1,5

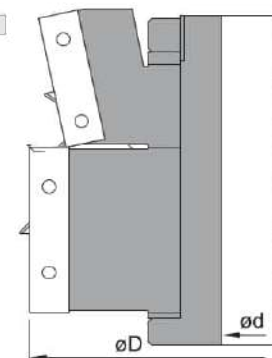
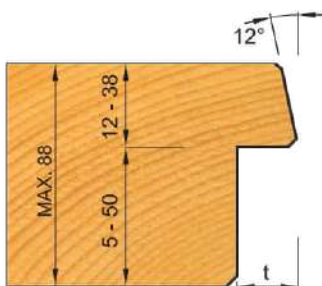

K449	FALCOVACIA SADA NA DVERE S TESNENÍM		HW				
$\varnothing D$	$\varnothing d$	Z	Nr SET	€			
160	30	2+2	615K4490030R3	865,00			

osadené v nástroji R 3 opcia 45° R 1,5

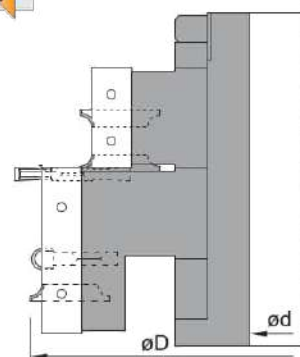
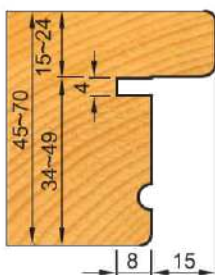



8373 SADA FRÉZ NA DVEROVÉ LIŠTY HW 

KLASIK					
TYP	ø D	ø d	Z	Nr	€
1	131	30	2	11183731	265,00
2	140	30	2	11183732	195,00
3	119	30	2	11183733	195,00

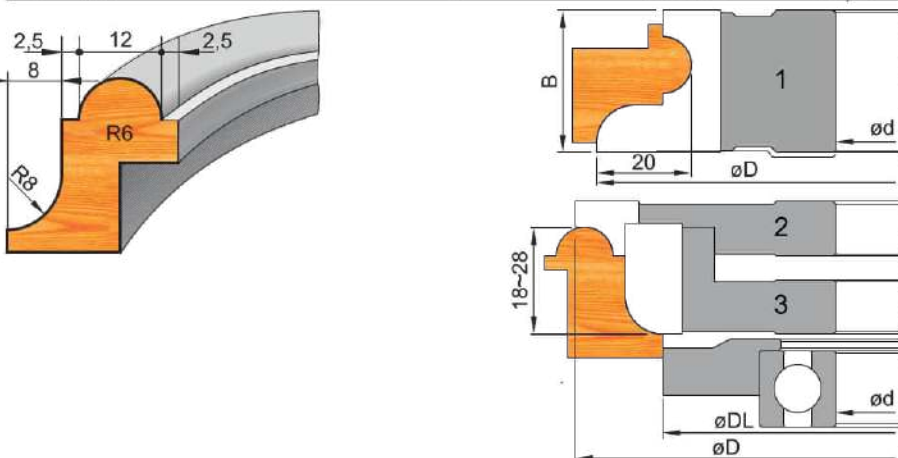

RUSTIK - SET				
ø D	ø d	Z	€	
137	30	2+2	871,20	

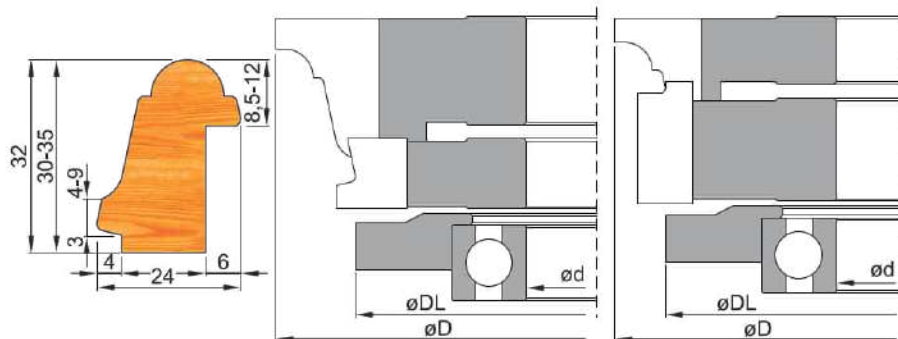

HISTORIK - SET				
ø D	ø d	Z	€	
176	30	2	440,00	

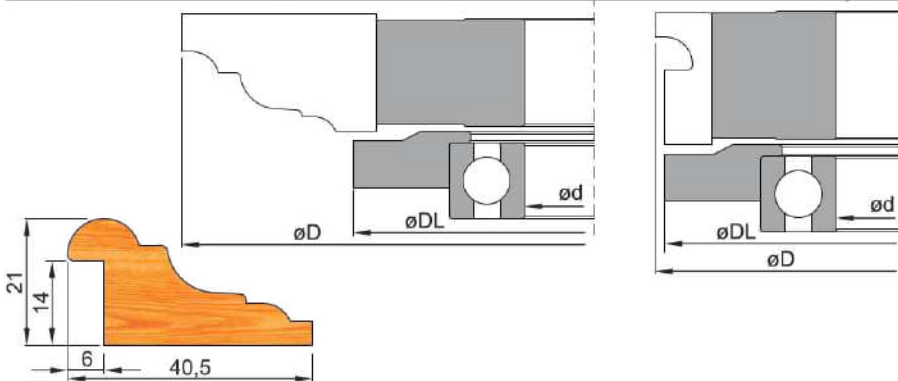

ZÁKAZKOVÉ FRÉZY NA PROFILOVÉ LIŠTY HW, HS, SP 

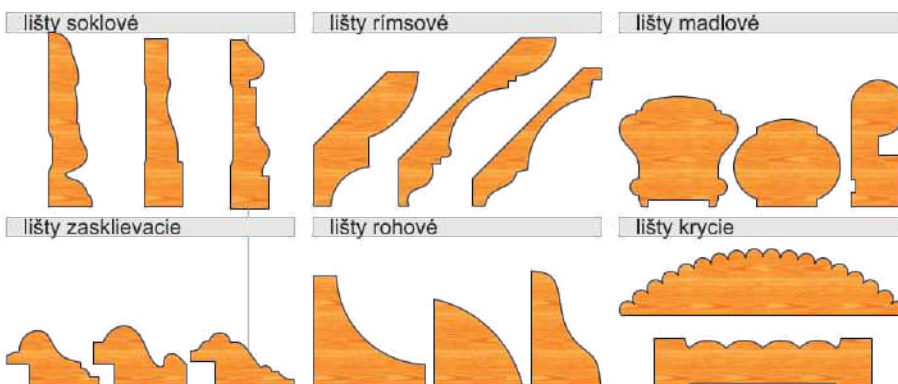

Vyrábame zákazkové profilové frézy. Vyžiadajte si katalóg profilov pre Vašu inšpiráciu.





5061.1 ZÁRUBŇOVÁ SADA ECONOMY					
	ø D	ø d	Z	Nr	€
SET	157	30	4	11150611	599,00
Fréza č.3	157	30	4	11114872	264,00

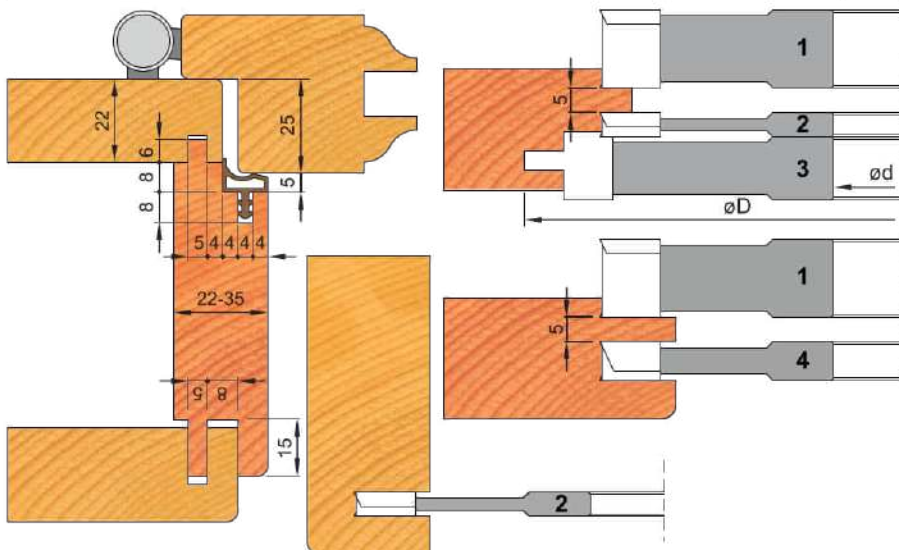

Základná sada na obložkové masívne zárubne. Určená na remeselné použitie. Tvarovú frézu na tesnenie je možné objednať aj samostatne.



T190 FRÉZY NA ZÁRUBNE – DRÁŽKA NA TESNENIE HW					
ø D	B	ø d	Z	Nr	€
160	20	30	4+2+2+2	235T190MS044784	440,00

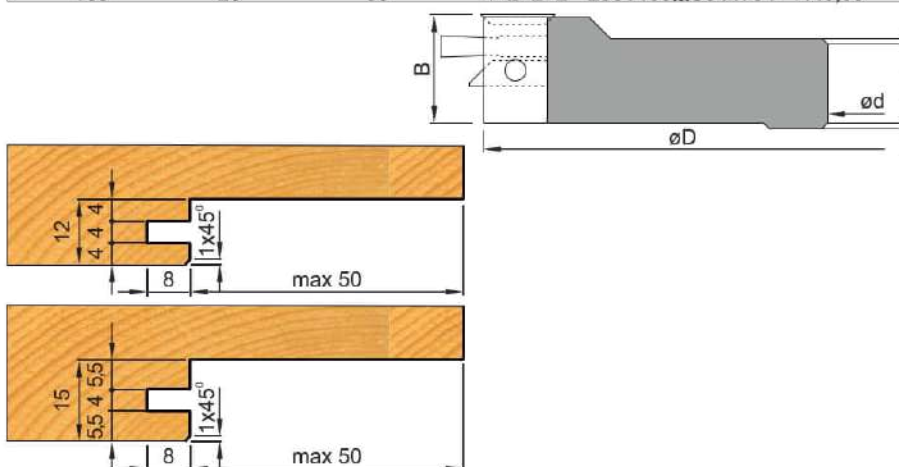

Žiletková fréza na frézovanie drážky na tesnenie šírky 12 a 15mm. Nástroj je určený predovšetkým na dyhované a laminované materiály. V kombinácii s ďalšími nástrojmi je vhodný na falcové aj bezfalcové dvere.

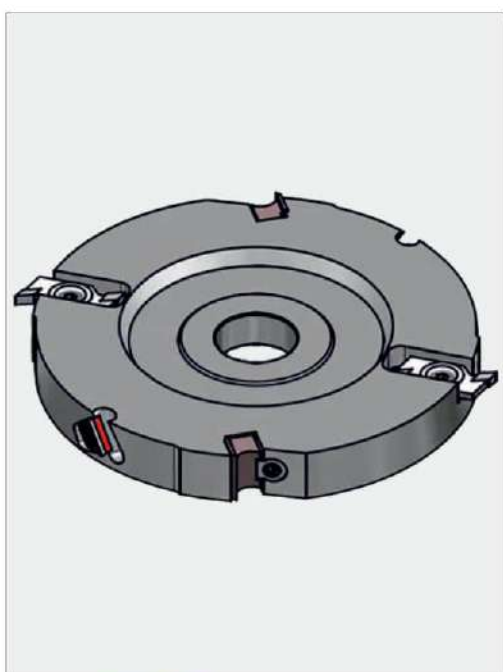

M059 FRÉZY NA ZÁRUBNE – LDTD DIA					
ø D	ø d	Z	Nr	€	
200	30	4+2+2+2+2	235GRSPTM059358	678,00	

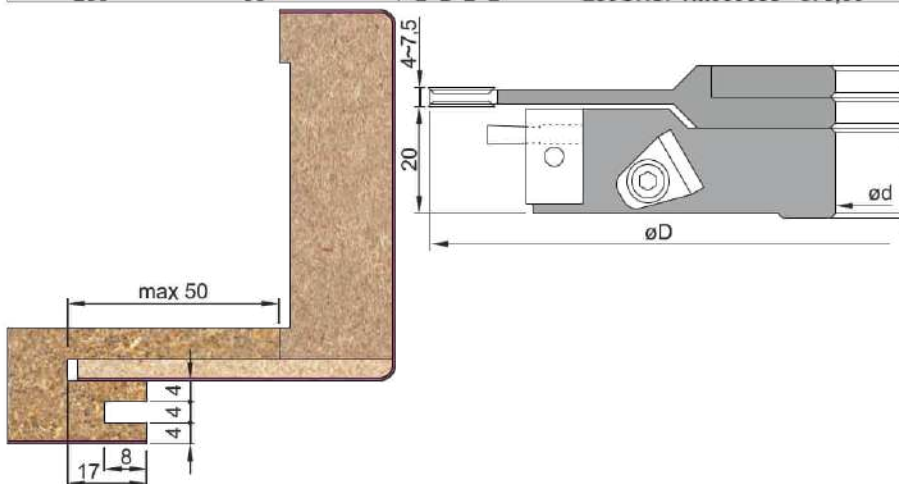

Žiletková fréza na frézovanie na dyhované a laminované materiály. Doplnením o DIA segment v spodnej časti je možné dosiahnuť veľmi vysokú životnosť nástroja. Podľa hĺbky zafrézovania je možné vyrobiť zárubňu pre falcové aj bezfalcové dvere.



A35423 ZÁRUBŇOVÁ SADA PROFI

HW



ø D	ø d	Z	Nr	€
157	30	2+2	615A35423	1 328,80

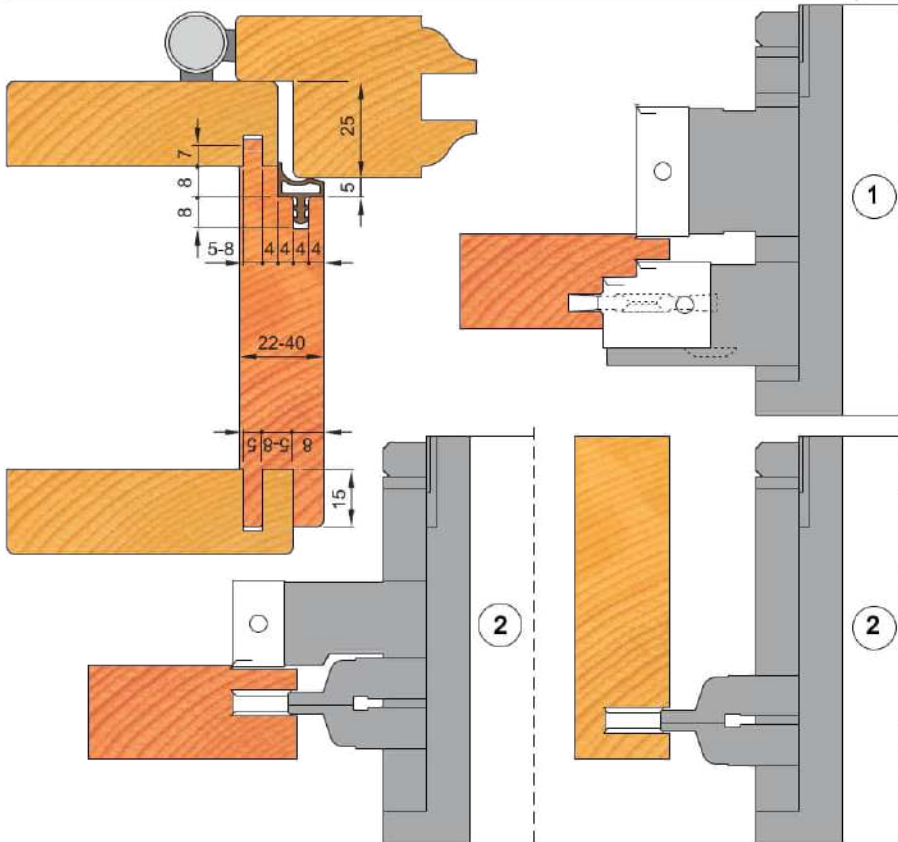

Sada nástrojov na výrobu kompletnej obložkovej zárubne. Sada pozostáva z dvoch zostáv nástrojov. V sade je zakomponovaná nastaviteľná drážkovacia fréza, ktorá umožňuje aj zosilnenú konštrukciu spojovacieho pera.

ROZŠÍRENIE NA TESNENIE ŠÍRKY 15MM

žiletka	Nr	€
	615A3542A2	58,00

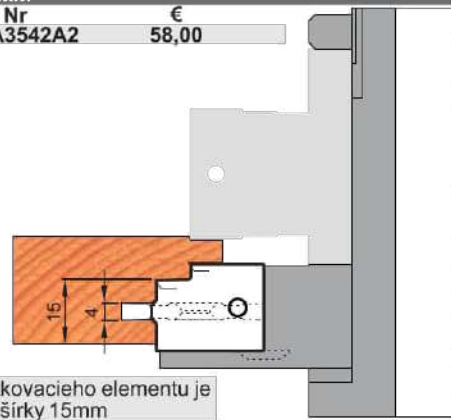

Doplnením tvarovej žiletky a prestavením drážkovacieho elementu je možné robiť aj obložkové zárubne pre tesnenie šírky 15mm

ROZŠÍRENIE NA BEZFALCOVÉ DVERE

ø D	ø d	Z	Nr	€
187	50	2+2	615A5201	759,00

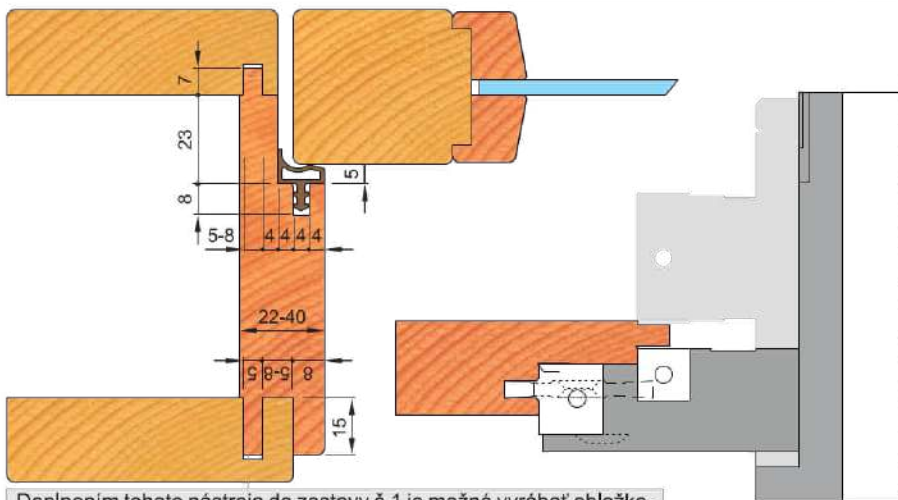

Doplnením tohoto nástroja do zostavy č.1 je možné vyrábať obložkové zárubne pre bezfalcové dvere.





302 PÚZDRA

ø D	B	Nr (ød=30)	€	Nr (ød=40)	€
50	95	6150302059530	64,00	6150302059540	64,00
50	110	6150302051130	64,00	6150302051140	64,00
50	130	6150302051330	64,00	6150302051340	64,00
60	110	6150302061130	64,00	6150302061140	64,00
60	130	6150302061330	64,00	6150302061340	64,00
ø D	B			Nr (ød=50)	€
60	60			6150302066050	64,00
60	70			6150302067050	64,00
60	80			6150302068050	64,00
60	90			6150302069050	64,00
60	100			6150302061050	64,00
60	110			6150302061150	64,00
60	120			6150302061250	69,00
60	130			6150302061350	64,00
60	140			6150302061450	64,00

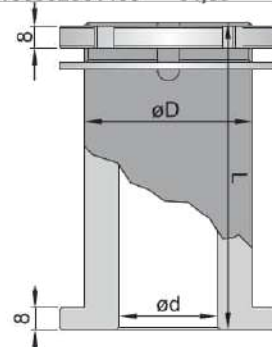

303 - A UPÍNACÍ KLÍČ

ø D	Nr	€
40 - 42	6150303A40420	18,20
52 - 55	6150303A52550	18,20
62 - 65	6150303A62650	21,10
68 - 75	6150303A68750	21,10
80 - 90	6150303A80900	24,90

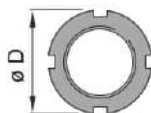

371 MEDZIKRÚŽKY

ø D	B	ø d	Nr	€	ø D	B	ø d	Nr	€
50	0,1	30	6150371A00130	1,40	60	0,1	40	6150371A00140	1,40
50	0,5	30	6150371A00530	1,40	60	0,5	40	6150371A00540	1,40
50	1	30	6150371A01030	1,40	60	1	40	6150371A01040	1,40
50	2	30	6150371A02030	4,20	60	2	40	6150371A02040	5,50
50	3	30	6150371A03030	4,70	60	3	40	6150371A03040	5,80
50	4	30	6150371A04030	6,00	60	4	40	6150371A04040	7,30
50	5	30	6150371A05030	6,20	60	5	40	6150371A05040	7,60
50	6	30	6150371A06030	6,30	60	6	40	6150371A06040	8,20
50	8	30	6150371A08030	6,80	60	8	40	6150371A08040	8,80
50	10	30	6150371A10030	7,30	60	10	40	6150371A10040	9,50
50	12	30	6150371A12030	7,70	60	12	40	6150371A12040	10,00
50	14	30	6150371A14030	8,60	60	14	40	6150371A14040	11,00
50	16	30	6150371A16030	9,00	60	16	40	6150371A16040	10,30
50	18	30	6150371A18030	9,70	60	18	40	6150371A18040	10,70
50	20	30	6150371A20030	10,00	60	20	40	6150371A20040	12,90
ø D	B	ø d	Nr	€	ø D	B	ø d	Nr	€
70	0,1	50	6150371A00150	1,40	80	0,1	60	6150371A00160	1,40
70	0,5	50	6150371A00550	1,40	80	0,5	60	6150371A00560	1,40
70	1	50	6150371A01050	1,40	80	1	60	6150371A01060	1,40
70	2	50	6150371A02050	5,80	80	2	60	6150371A02060	1,40
70	3	50	6150371A03050	7,60	80	3	60	6150371A03060	8,40
70	4	50	6150371A04050	7,90	80	4	60	6150371A04060	9,00
70	5	50	6150371A05050	8,40	80	5	60	6150371A05060	9,40
70	8	50	6150371A08050	9,40	80	8	60	6150371A08060	10,30
70	10	50	6150371A10050	10,00	80	10	60	6150371A10060	11,00
70	12	50	6150371A12050	10,50	80	12	60	6150371A12060	12,10
70	14	50	6150371A14050	11,70	80	14	60	6150371A14060	12,70
70	16	50	6150371A16050	12,40	80	16	60	6150371A16060	13,54
70	18	50	6150371A18050	12,90	80	18	60	6150371A18060	13,80
70	20	50	6150371A20050	13,70	80	20	60	6150371A20060	14,50

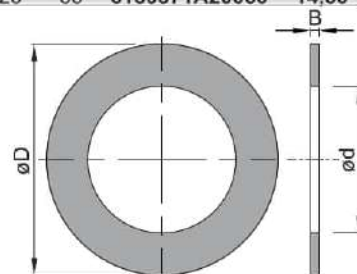



372 VNÚTORNÉ REDUKCIE			
ø D	B	Nr	€
35	30	3011351	6,00
40	30	301135	6,30

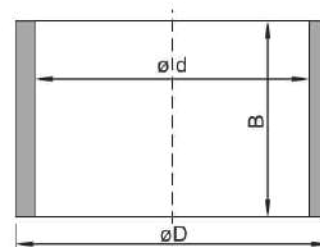
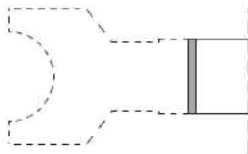

XX



373 PRÍRUBOVÉ REDUKCIE			
ø D	ø d	Nr	€
35	30	301137	8,50
40	30	301132	8,50
40	35	301136	8,50
50	30	301133	8,50
50	40	301134	8,50

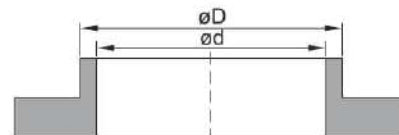
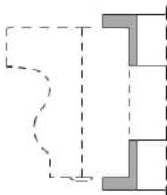

301 KOPÍROVACIE LOŽISKO				
	ø D	ø d	Nr	€
ložisko 30/55		55	301803016	17,50
puzdro malé	max.120			
ložisko 30/80		80	301131L	4,50
puzdro veľké	max.200			

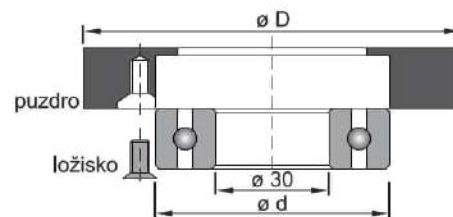

Vyrábame zákazkové puzdrá pre ložiská podľa požiadavky na ich priemer a tvar.

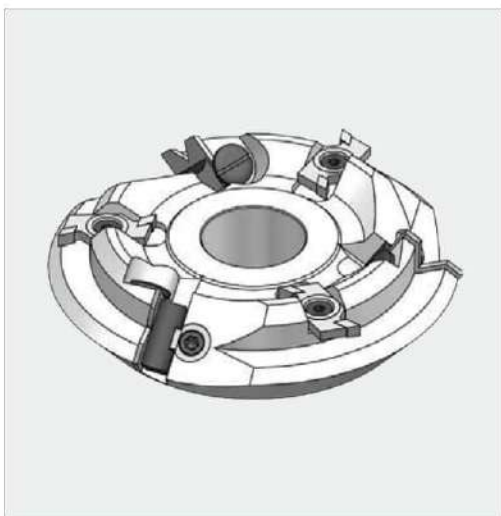

ZÁKAZKOVÉ ÚPRAVY FRÉZ

Zaobľovanie 30,70 €	Zrážanie 30,70 €	Drážkovanie 33,20 €	Predrezávanie 34,40 €
------------------------	---------------------	------------------------	--------------------------

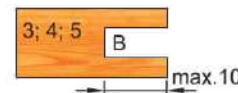

Do nosiča frézy vyhotovujeme podľa požiadaviek sedlá pre osadenie rôznych elementov. Cena zahŕňa jedno sedlo, element a skrutku.

Vašu úpravu urobíme do 5p. dní!



PRÍTLAČNÉ SKRUTKY S ČAPOM

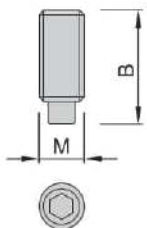

M	B	Nr	€
5	12	6150480700512	0,92
6	8	6150480700608	0,92
6	12	6150480700612	1,33
6	15	6150480700615	0,92
6	20	6150480700620	0,92
8	12	6150480700812	0,92
8	15	6150480700815	0,92
8	20	6150480700820	1,00
10	20	6150480701020	1,10
10	20	6150480701225	1,10

PRÍTLAČNÉ SKRUTKY S PLOCHÝM KONCOM

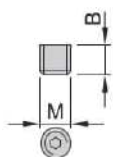

M	B	Nr	€
2,5	2,5	615048070P202	3,58
4	4	615048070P404	3,67
5	5	615048070P505	1,25

SKRUTKY S KUŽELOVOU HLAVOU

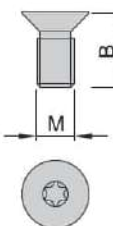

M	B	Nr	€
5	6,5	615048074A507	1,92
5	10	615048074A510	1,92

SKRUTKY S OSADENÍM

C516

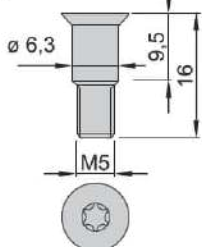

Nr	€
615048074C516	3,33

SKRUTKY S OSADENÍM

C512

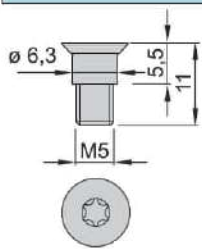

Nr	€
615048074C512	2,50

SKRUTKY S OSADENÍM

74B

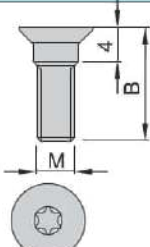

M	B	Nr	€
5	10	615048074B510	1,50
5	12	615048074B512	1,92
5	15	615048074B515	2,33
5	18	615048074B518	1,50

SKRUTKY S OSADENÍM

C514

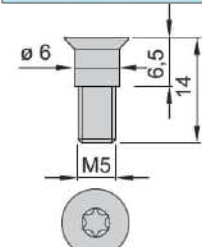

Nr	€
615048074C514	2,50

SKRUTKY S OSADENÍM

C515

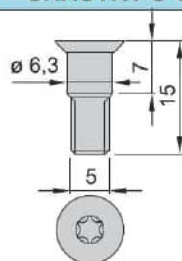

Nr	€
615048074C515	3,33

DORAZOVÉ SKRUTKY

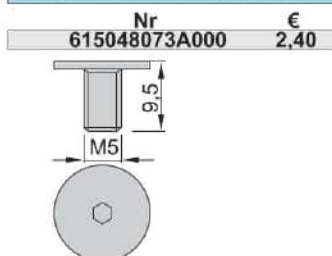

Nr	€
615048073A000	2,40

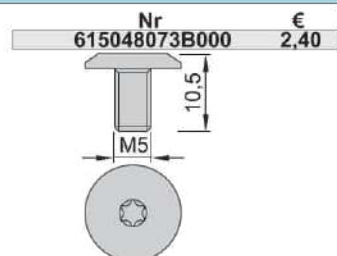

Nr	€
615048073B000	2,40

DIFERENČNÉ SKRUTKY

M1=M2	B	Nr	€
8	22	280VT19MBB9	2,90
6	20	111448	3,09
5	20	111448.1	1,20

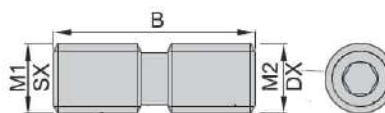

PRÍTLAČNÉ SKRUTKY S HLAVOU

PRÍTLAČNÉ SKRUTKY S HLAVOU

Nr	€
615048074P350	1,44

Nr	€
615048074P460	1,44

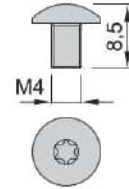
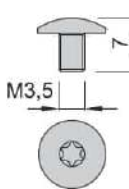

DISTAČNÉ PODLOŽKY

ø D	B	ø d	Nr	€
15	0,1	5,25	6150480750015	1,25
15	0,5	5,25	6150480750055	1,25
15	1	5,25	6150480750105	1,25
13	0,1	6,5	6150480750016	1,25
13	0,5	6,5	6150480750056	1,25
13	1	6,5	6150480750106	1,25

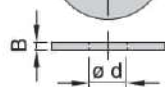

MATICE ŠPECIÁLNE

Nr	€
615048020D000	2,70

Nr	€
615048020E000	2,70

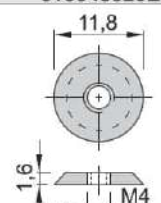
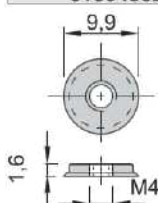

UPÍNACIE SKRUTKY

Nr	€
615048020C000	2,70

M	B	Nr	€
3,5	7	6150480730407	7,20
3,5	9	6150480730409	7,20

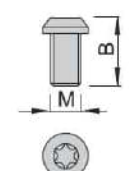
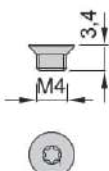



OKENNÉ SYSTÉMY



eshop.woodb.sk

VARIANTY USPORIADANIA

Zasklievacia lišta



Interiérové tesnenie



Dekompresná drážka



Tesnenie v ráme



Rámová AL lišta



Zraz rámu a krídla



Prahová AL lišta



Pozícia celoobvodového kovania



Kovanie dvojkrídlového zrazu

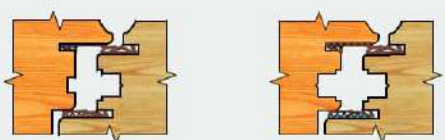

STAVEBNÉ VÝPLNE

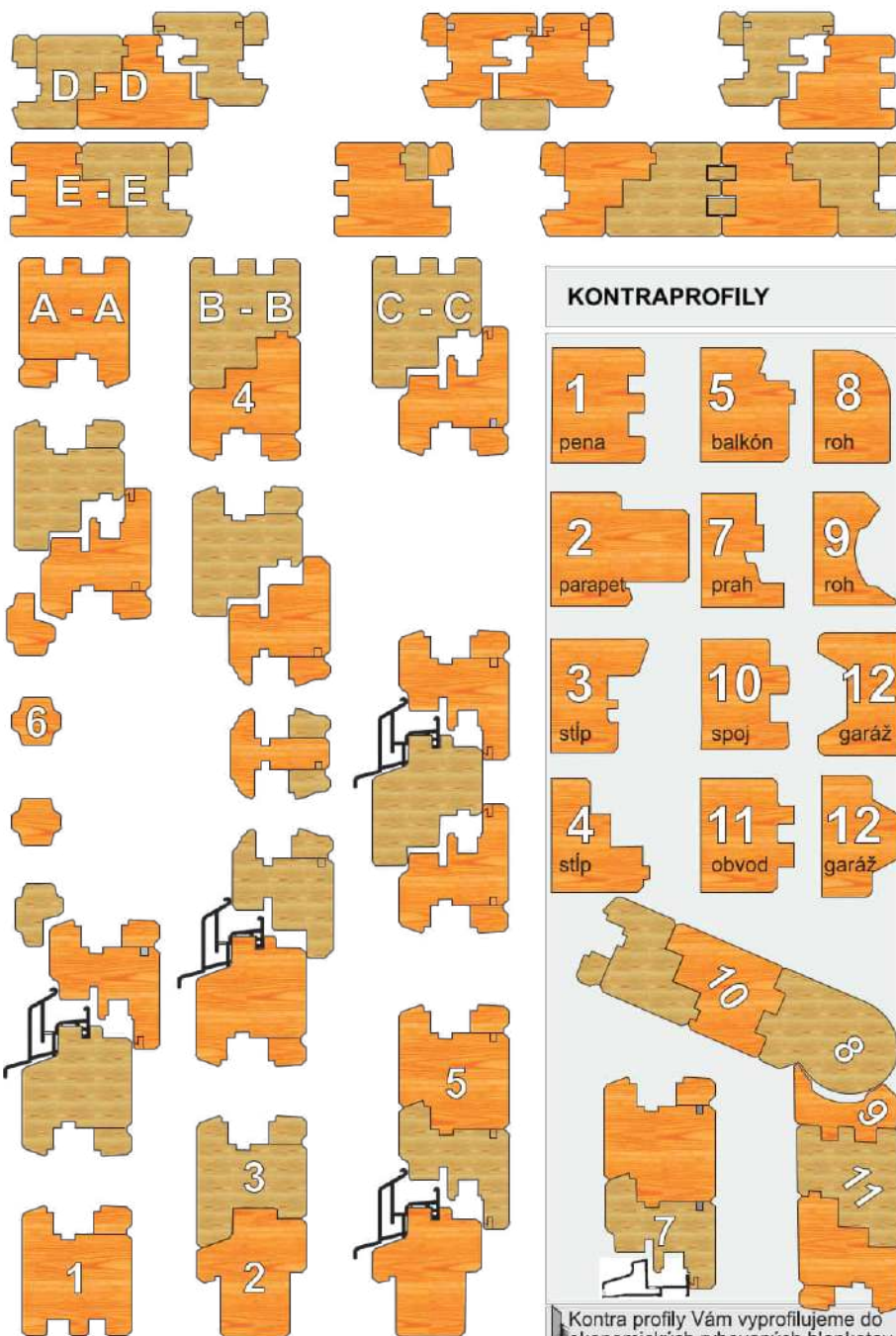
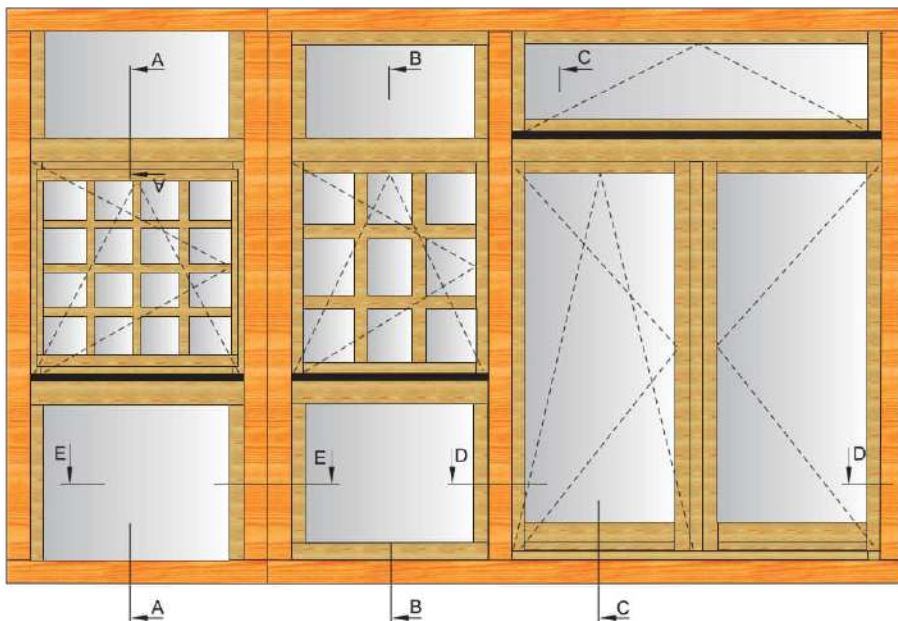

KONTRAPROFILY

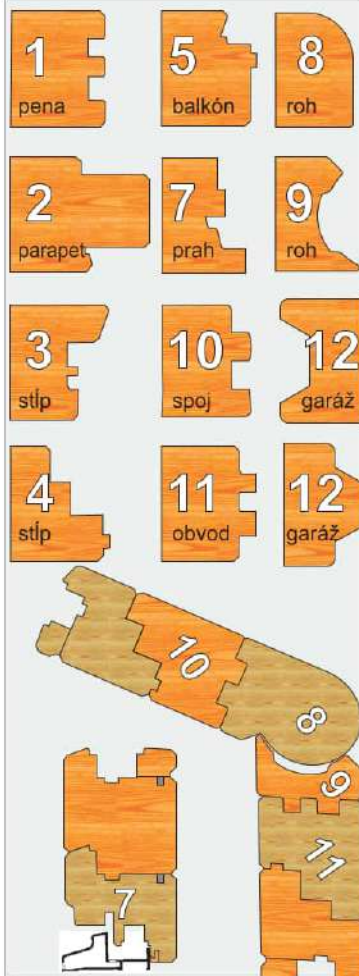

Kontra profily Vám vyprofilujeme do ekonomických ryhovaných blanketov.



	K443-B FRÉZY NA CELOOBVODOVÉ KOVANIE	HW			
$\varnothing D$	B	$\varnothing d$	Z	Nr	€
164	16,3	30 (40,50,60)	4 + 4 + 4	615K443B16430	224,00

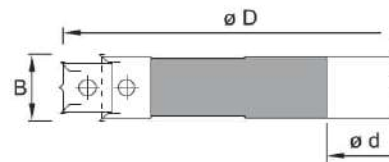
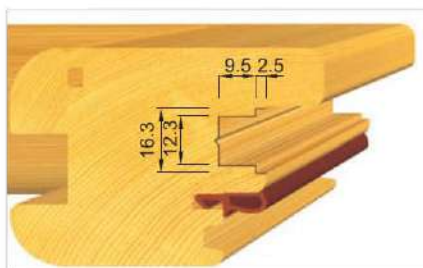

	K439-B FRÉZY NA HS PORTÁL	HW		
B	$\varnothing D$	$\varnothing d$	Nr	€
	160	30 - 50	615K439B16030	576,00

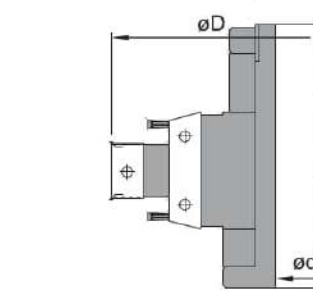
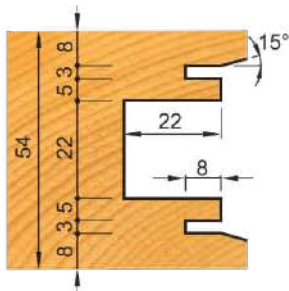

	K439-C FRÉZY NA HS PORTÁL	HW	
$\varnothing D$	$\varnothing d$	Nr	€
200	30 - 50	615K439C20030	299,00

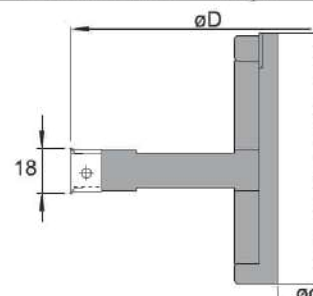
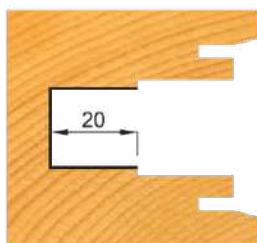

	K439-Z SADA FRÉZ NA PORTÁL	HW	
$\varnothing D$	$\varnothing d$	Nr	€
184	30 - 50	615K439023000	1 824,00
194	30 - 50	615K439033000	1 595,00
236	30 - 50	615K439Z23630	344,00

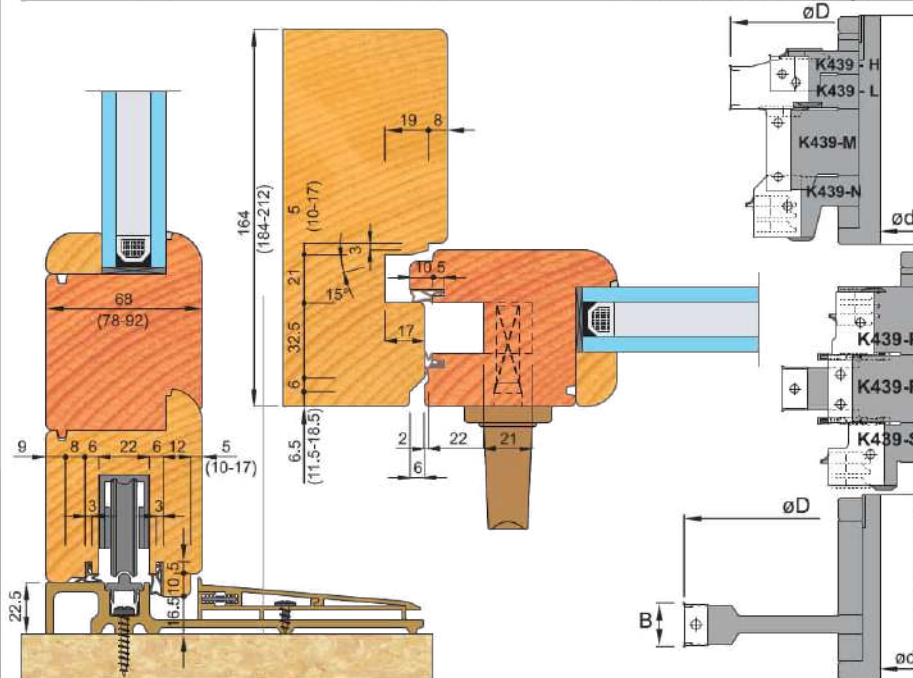

OBSAH

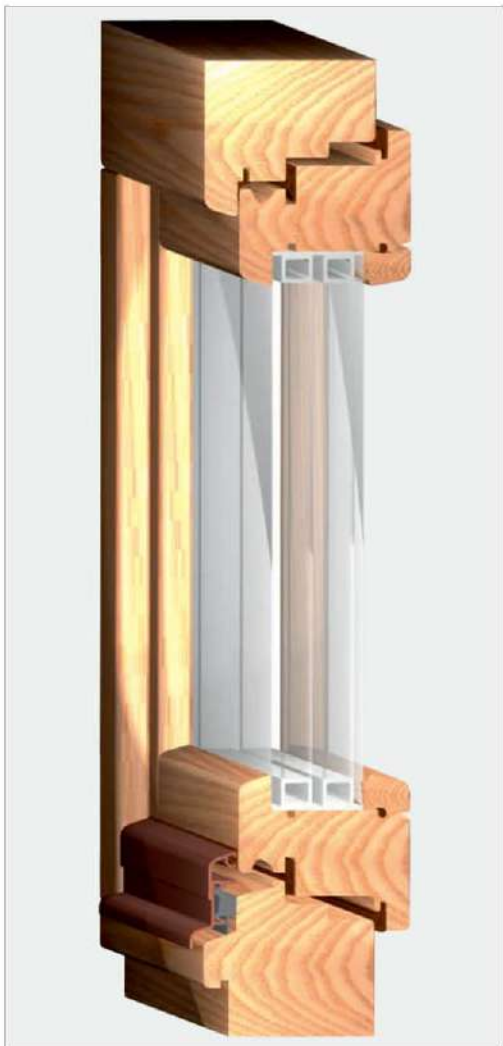

ECONOMY OKNO 78-88			HW	
$\varnothing D$	$\varnothing d$	Z	Nr SET	€
160-320	30 (40,50)	2	615K88	5 840,00

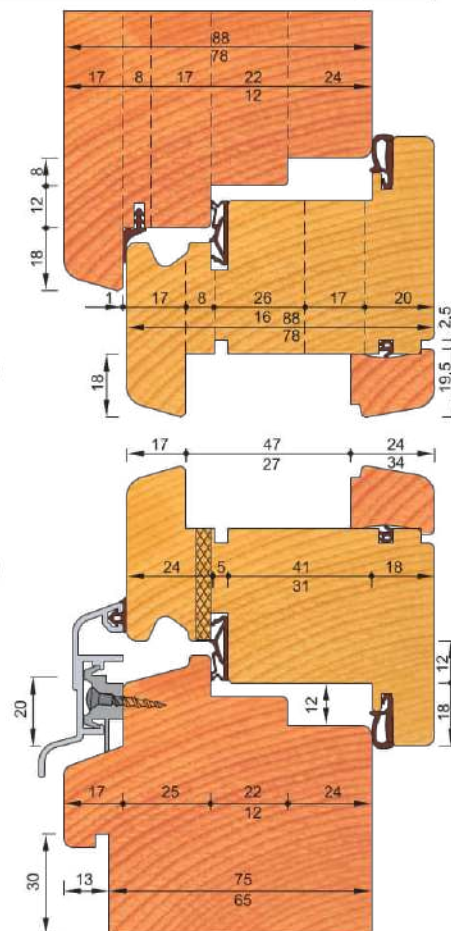
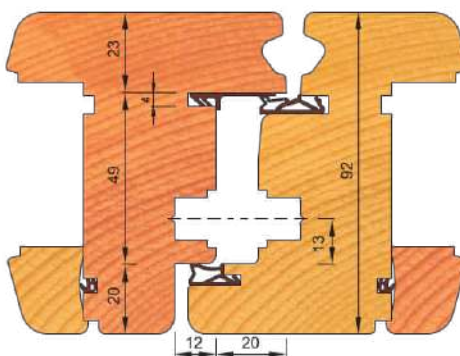

Technicky vyspelý a nadčasový okenný profil. Žiletkové nástroje so samocentrickým upínaním uložené v puzdre. Logický priemer a výška nástroja (netreba nastavovať bočné pravítko, ani výšku hriadeľa). Skladanie nástrojov bez možnosti omylu. Podrobný 3D manuál.



ECONOMY VCHODOVÉ DVERE 92			HW	
$\varnothing D$	$\varnothing d$	Z	Nr SET	€
160	30 (40,50)	2	615K92	1 320,00

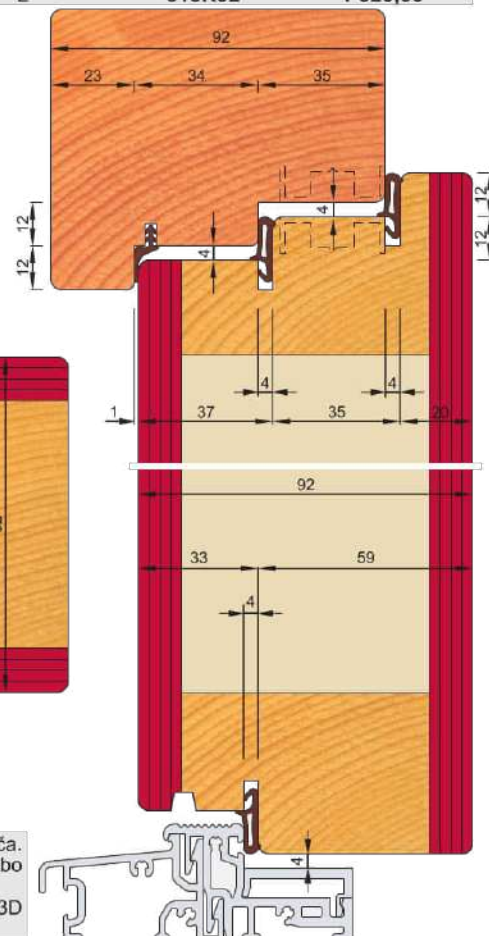
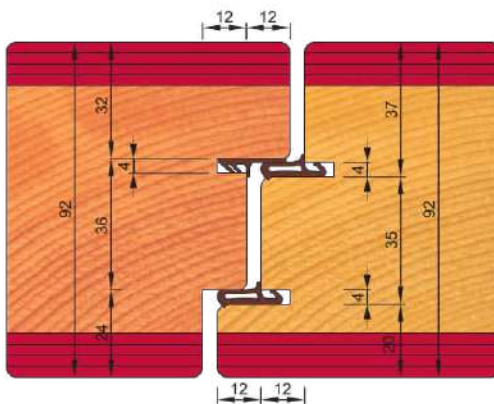

Prepracovaná dverová konštrukcia zo sendviča. Žiletkové nástroje v puzdre (spodná fréza), alebo za príplatok v HSK upínáku (CNC centrum). Neomylné prestavovanie nástroja. Podrobný 3D manuál.



DVEROVÝ SYSTÉM INTEGROVANÝ HW

HW



DVEROVÝ SYSTÉM 92 HW

HW

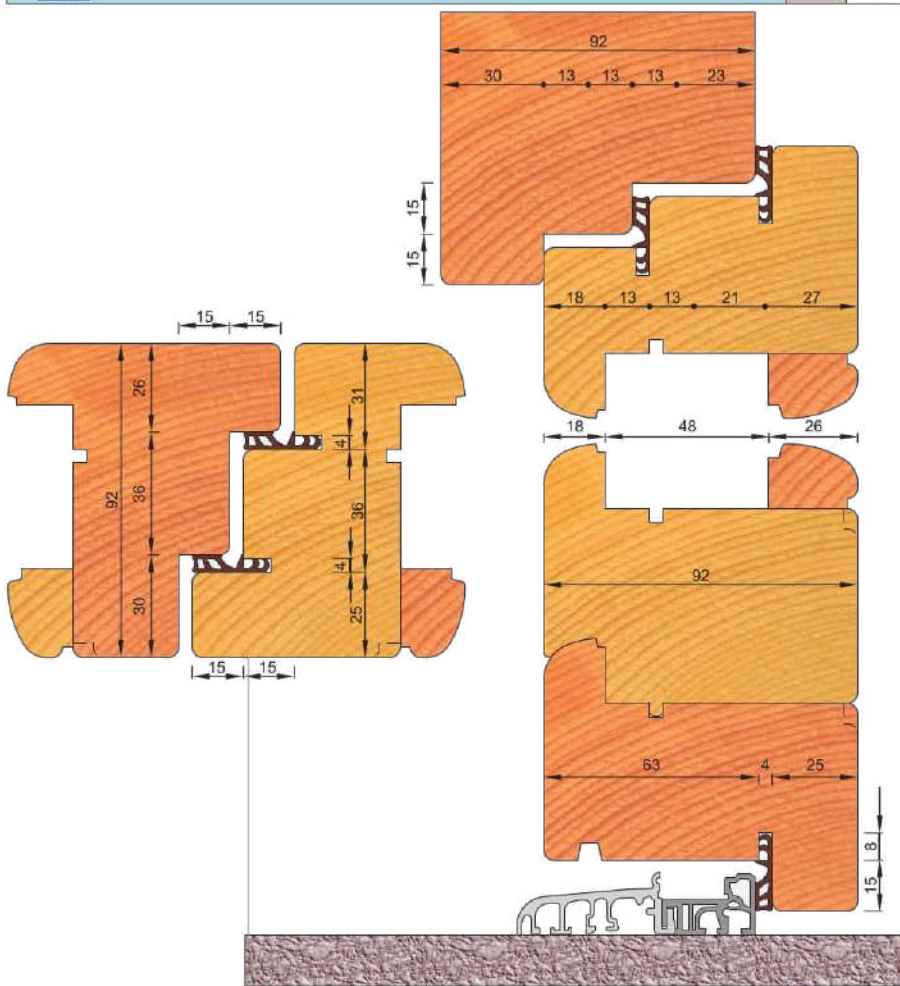

OBSAH

DREVOHLINÍKOVÉ OKNO INTEGRAL HW

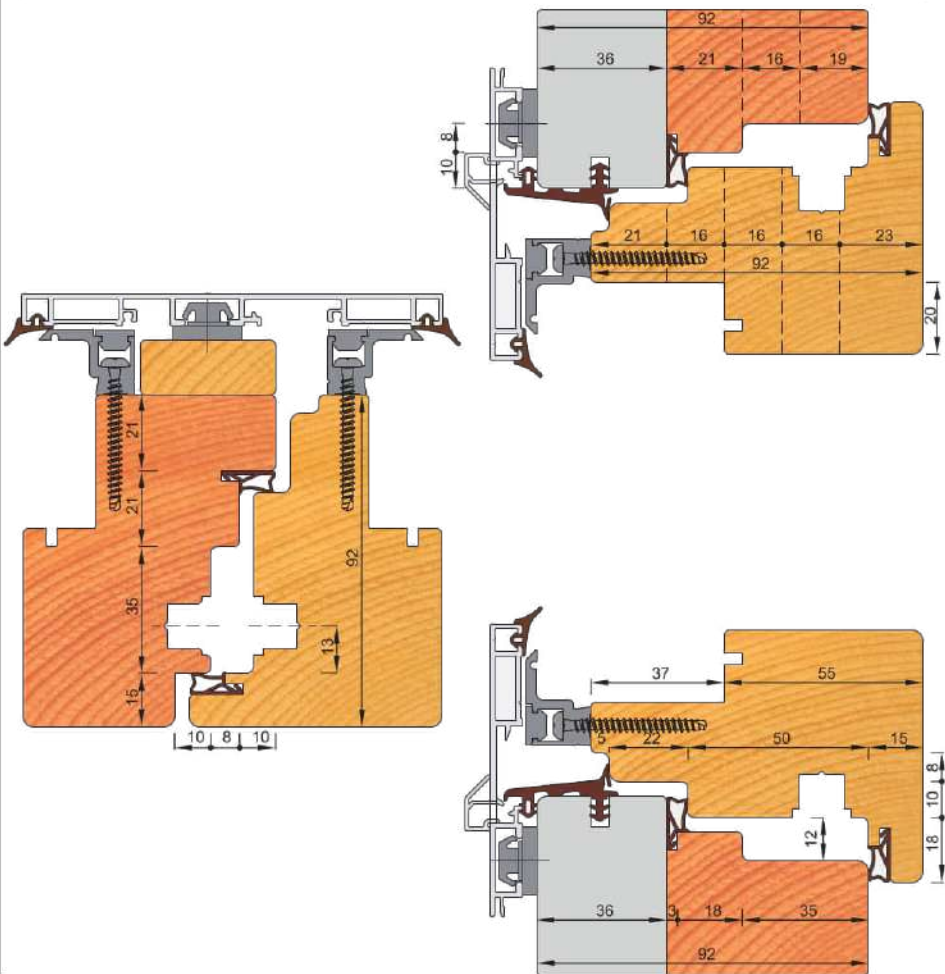

DREVOHLINÍKOVÉ OKNO KLASIK HW

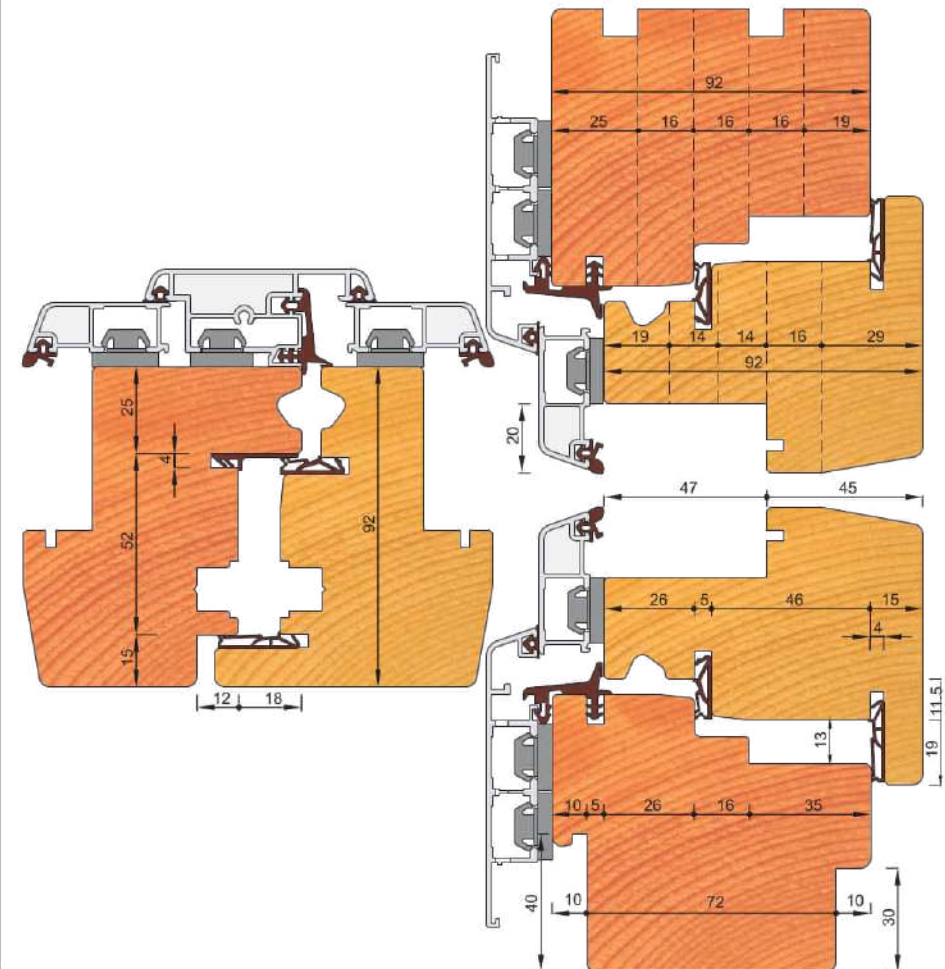



OKENNÝ SYSTÉM PASÍV

HW

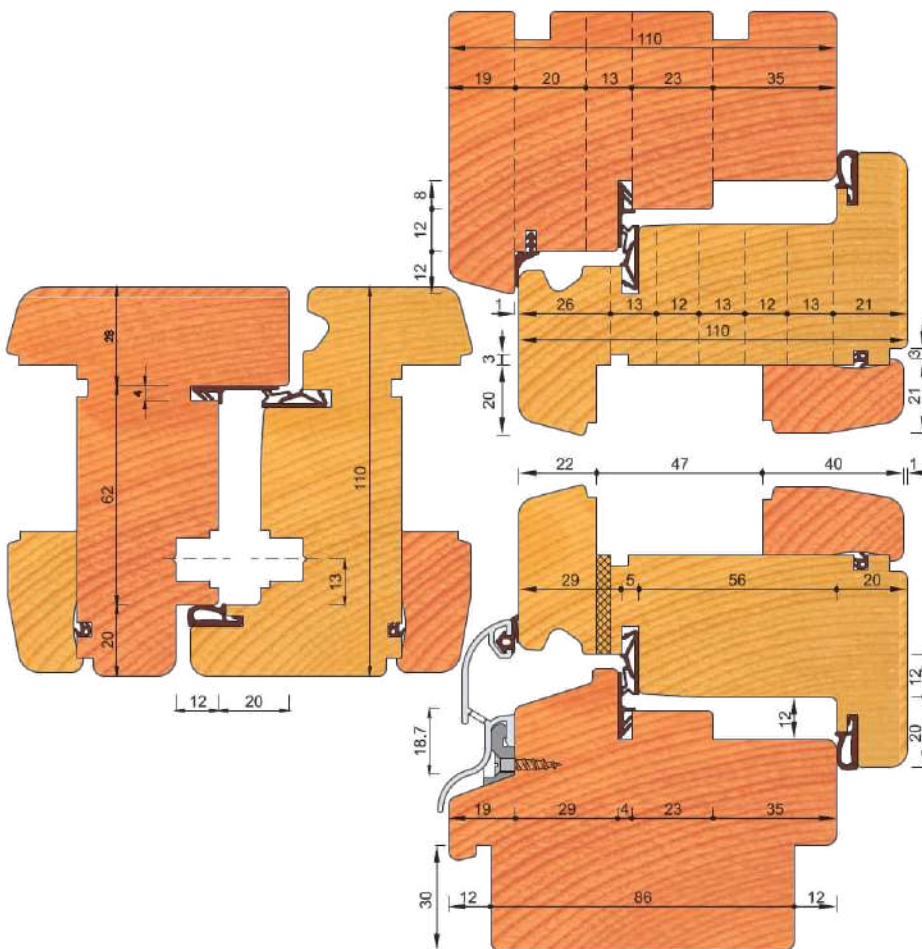

OKENNÝ SYSTÉM UNI

HW

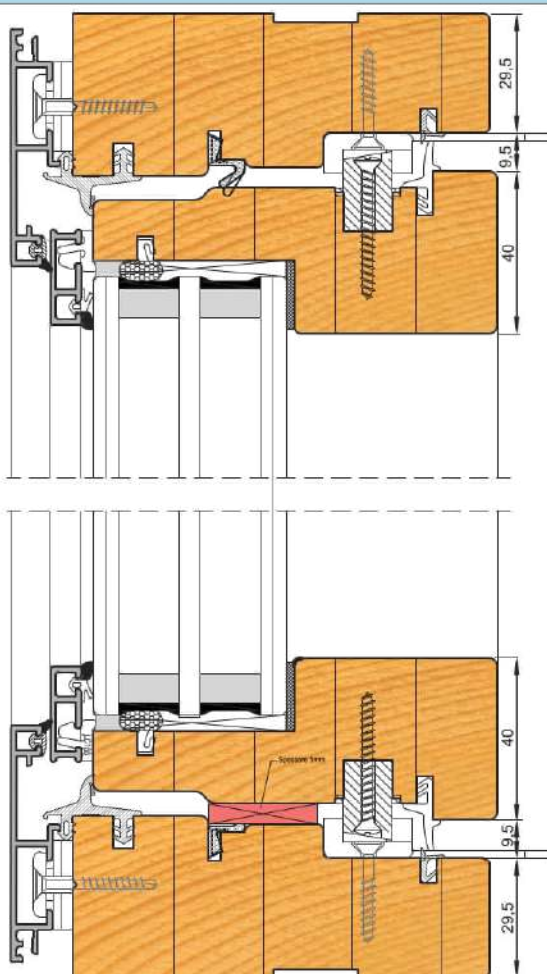



OKENNÝ SYSTÉM 78-92

HW

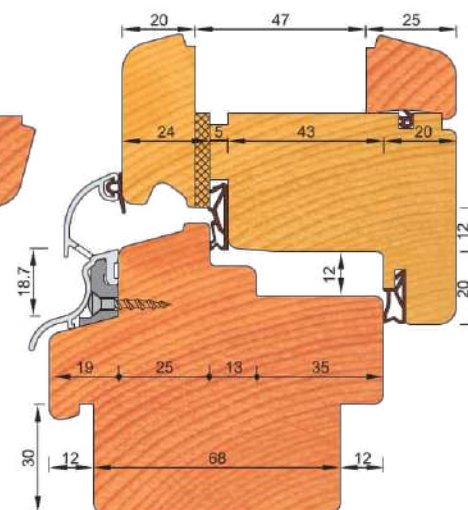
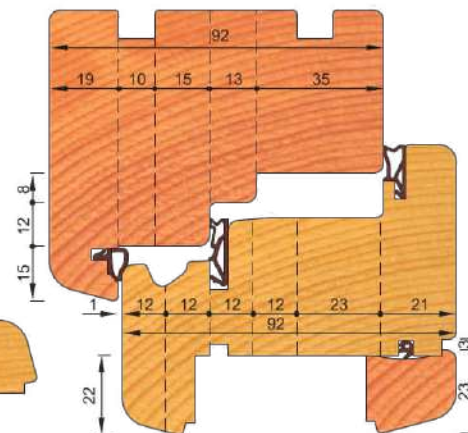
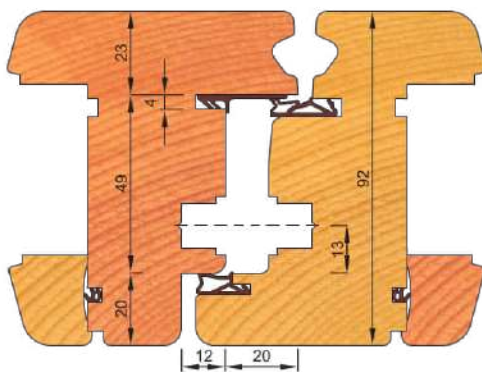

OKENNÝ SYSTÉM RUSTIK

HW

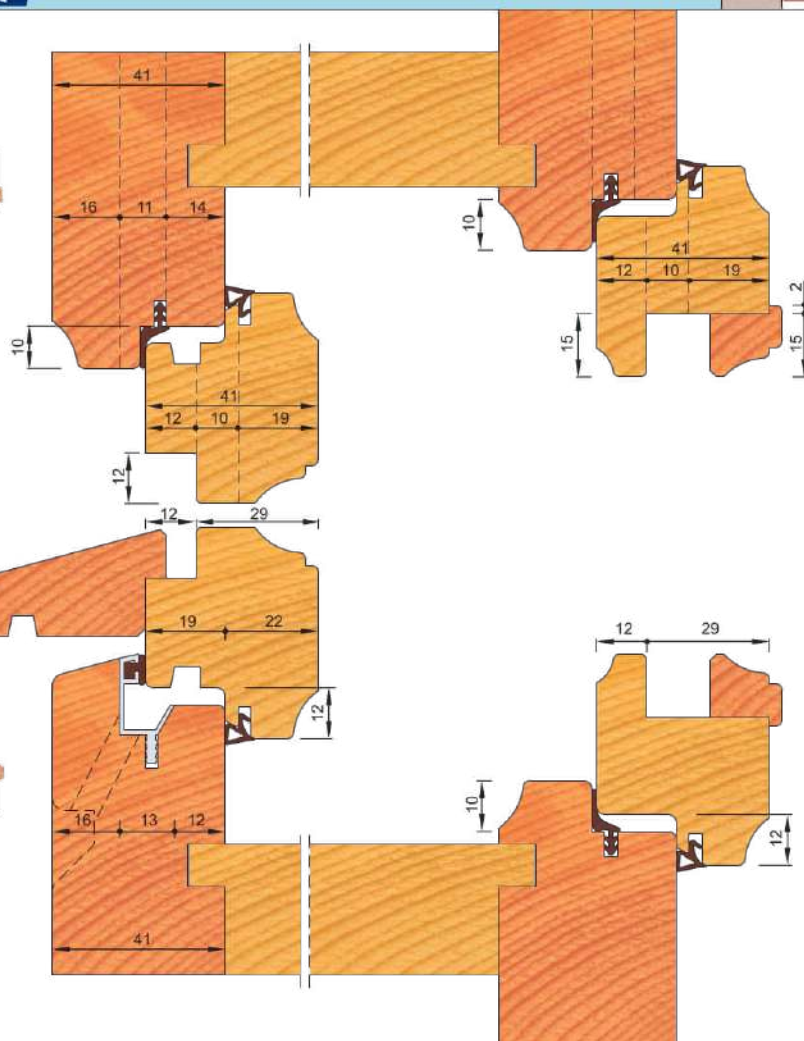

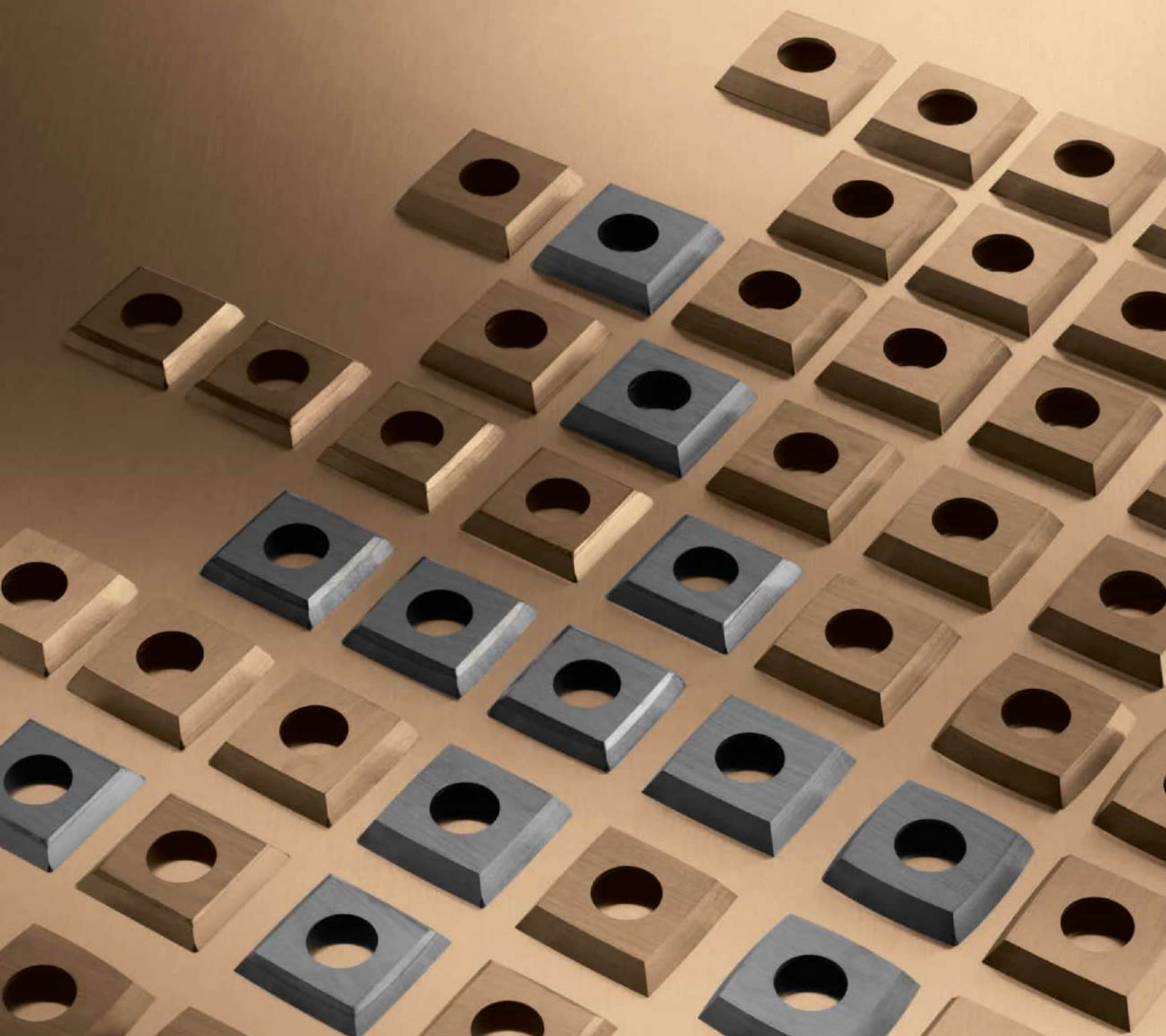

FRÉZOVACIE NOŽE





HOBLOVACIE NOŽE - ECONOMY

HSS

L	Nr	€
60	228H060303	6,05
80	228H080303	6,05
100	228H100303	6,05
120	228H120303	6,05
130	228H130303	6,60
140	228H140303	7,04
150	228H150303	7,59
160	228H160303	8,03
170	228H170303	8,58
180	228H180303	9,02
190	228H190303	9,57
200	228H200303	10,12
210	228H210303	10,56
230	228H230303	11,66
240	228H240303	12,10
250	228H250303	12,65
300	228H300303	13,75
310	228H310303	14,19
410	228H410303	16,74
430	228H430303	19,69
510	228H510303	23,43
520	228H520303	23,87
610	228H610303	27,94
630	228H630303	28,82

L	Nr	€
200	228H200353	10,78
210	228H210353	11,33
250	228H250353	13,42
300	228H300353	14,63
310	228H310353	15,18
410	228H410353	20,02
510	228H510353	24,97
550	228H550353	26,95
610	228H610353	29,81
640	228H640353	36,48
710	228H710353	34,76
810	228H810353	39,60
910	228H910353	44,55
1010	228H1010353	48,50

Ekonomická trieda hobľovacích nožov pre nenáročné aplikácie. Vhodné predovšetkým na mäkké druhy dreven a občasné používanie.



HOBLOVACIE NOŽE - INDUSTRY

HSS18%W

L	Nr	€
60	228T060303	6,60
80	228T080303	7,60
100	228T100303	6,60
120	228T120303	6,60
130	228T130303	7,15
140	228T140303	7,59
150	228T150303	8,25
160	228T160303	8,69
170	228T170303	10,80
180	228T180303	11,40
190	228T190303	10,45
200	228T200303	11,00
210	228T210303	11,55
230	228T230303	12,54
240	228T240303	15,20
250	228T250303	14,55
300	228T300303	16,50
310	228T310303	16,94
410	228T410303	23,62
430	228T430303	23,54
510	228T510303	27,90
520	228T520303	28,49
610	228T610303	32,50
630	228T630303	34,54

L	Nr	€
200	228T200353	11,99
210	228T210353	12,65
250	228T250353	15,07
300	228T300353	18,72
310	228T310353	19,30
410	228T410353	24,75
510	228T510353	30,69
550	228T550353	33,11
610	228T610353	38,06
640	228T640353	37,90
710	228T710353	42,79
810	228T810353	51,00
910	228T910353	54,67
1010	228T1010353	63,25

Priemyselná trieda hobľovacích nožov pre štandardné nasadenie. Vhodné na mäkké aj tvrdé druhy tuzemských dreven.



HOBLOVACIE NOŽE - POVLAKOVANÉ „MATRIX“

HSSC

L	Nr	€
100	540M100303	16,70
120	540M120303	20,00
130	540M130303	21,70
150	540M150303	25,10
180	540M180303	30,10
210	540M210303	35,10
230	540M230303	38,40
240	540M240303	40,10
300	540M300303	50,10
310	540M310303	51,80
410	540M410303	68,50
510	540M510303	85,20

L	Nr	€
180	540M200353	32,10
210	540M210353	37,50
240	540M250353	42,90
300	540M300353	53,60
310	540M310353	55,40
410	540M410353	73,30
510	540M510353	91,20
610	540M610353	109,00
640	540M640353	114,40
710	540M710353	126,90
810	540M810353	144,80
1050	540M1010353	178,70

Priemyselná trieda povlakovaných hobľovacích nožov pre vysoké zaťaženie. Vhodné najmä na mäkké dreveny s vypadavými hrčami. Použitý druh povlaku predlžuje životnosť nožov, znižuje trenie a zabráňuje nalepovaniu živíc a triesok na čelnej ploche noža.



HOBLOVACIE NOŽE - TVRDOKOVOVÉ

HW

L	Nr	€
100	540HM100303	20,70
120	540HM120303	24,90
130	540HM130303	26,90
150	540HM150303	31,10
180	540HM180303	37,20
210	540HM210303	43,50
230	540HM230303	47,60
240	540HM240303	49,70
300	540HM300303	58,20
310	540HM310303	60,20
410	540HM410303	79,60
510	540HM510303	99,00

L	Nr	€
200	540HM200353	33,50
210	540HM210353	35,10
250	540HM250353	41,80
300	540HM300353	47,10
310	540HM310353	48,70
410	540HM410353	64,40
510	540HM510353	80,10
610	540HM610353	98,90
640	540HM640353	100,50
710	540HM710353	111,40
810	540HM810353	127,10
1010	540HM1010353	141,20

Hobľovacie nože s naspájkovaným spekaným karbidom. Určené pre abrazívne, tvrdé a exotické druhy materiálov.



HOBLŔOVACIE NOŽE - ŠPECIÁL

HSS

Typ ROJEK			Typ KDR		
b x h x a	Nr	€	b x h x a	Nr	€
200x53x3	222RJK200533	34,20	200x23x3	222KDR200233	16,25
310x30x3	222RJK310303	21,58	250x20x3	222KDR250203	19,20
410x30x3	222RJK410303	27,90			
510x30x3	222RJK510303	41,00			

Hoblňovacie nože s upínacími drážkami pre konkrétny typ stroja. Materiál HSS.

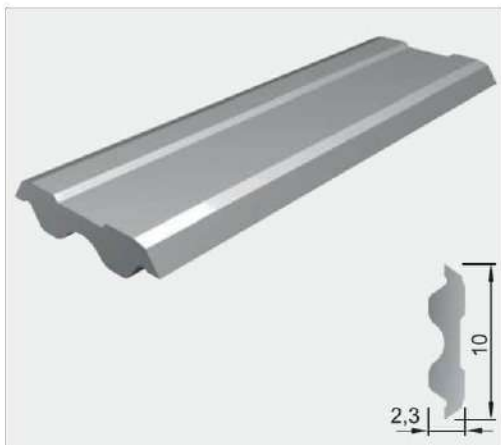

SAMOCENTRICKÉ OBOJSTRANNÉ NOŽE - TERSA

L	HSS mäkké dreveniny		M42 mäkké a tvrdé dreveniny		HW tvrdé a exotické dreveniny	
	Nr	€	Nr	€	Nr	€
100	234TRH100	4,50	234TRM100	5,70	54055509	84,20
110	234TRH110	4,95	234TRM110	6,27	540100849	40,76
130	234TRH130	5,85	234TRM130	7,41	54055510	48,00
135	234TRH135	6,08	234TRM135	7,70	540103823	50,72
180	234TRH180	8,10	234TRM180	10,26	540100854	66,12
185	234TRH185	8,33	234TRM185	10,55	540105070	67,96
230	234TRH230	10,35	234TRM230	13,11	54055511	84,22
235	234TRH235	10,58	234TRM235	13,40	540103824	86,72
410	234TRH410	18,45	234TRM410	23,37	54055513	147,36
520	234TRH520	23,40	234TRM520	29,64	54055516	186,60
1mm	2342010	0,05	2344010	0,06		

Samocentrický systém upínania s vysokým dôrazom na malý rezný odpor a vysokú kvalitu obrobenej plochy. Uvedený je sortiment najčastejšie používaných dĺžok. Nože z materiálov HSS a M42 skracujeme na požadovanú dĺžku.

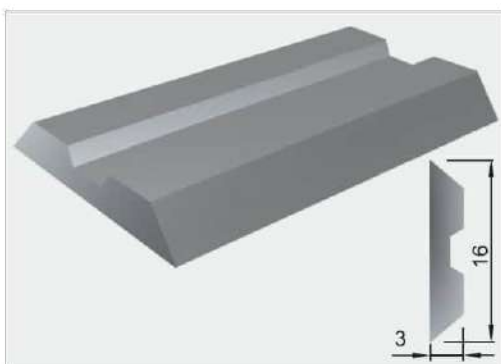

SAMOCENTRICKÉ OBOJSTRANNÉ NOŽE - CENTROLOCK

L	M42 mäkké dreveniny		HW tvrdé a exotické dreveniny	
	Nr	€	Nr	€
50	112B155020050	4,33	540102778	38,96
60	112B155020060	4,33	540100837	20,86
100	112B155020100	6,98	54055502	34,60
130	112B155020130	8,91	54055503	42,80
190	112B155020190	12,89	540100841	61,58
230	112B155020230	15,53	54054753	74,12
240	112B155020240	16,20	54055505	77,60

Samocentrický systém upínania s možnosťou viacnásobného ostrenia a dlhou životnosťou.

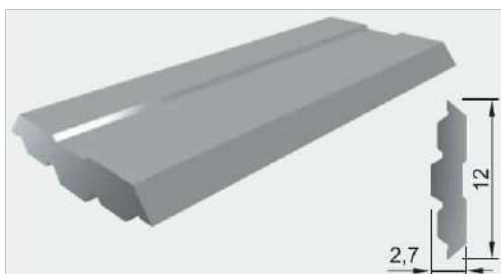

SAMOCENTRICKÉ OBOJSTRANNÉ NOŽE - CENTROFIX/CENTROSTAR

L	HSS 18%W mäkké a tvrdé druhy drevenin		HW tvrdé a exotické dreveniny	
	Nr	€	Nr	€
410	540114777	25,92	54055523	171,72
510	540114781	35,48	54055524	35,48
640	540114786	44,48	540107554	268,00

Samocentrický systém upínania určený prevažne pre zrovnávačky a hrúbkovačky.



SAMOCENTRICKÉ OBOJSTRANNÉ NOŽE - VARIPLAN

L	HSS 18%W mäkké a tvrdé druhy drevenin		HW tvrdé a exotické dreveniny	
	Nr	€	Nr	€
130	540116319	17,44	540109662	79,74
180	540116745	18,80	540116771	90,36
190	540116746	19,88	540116772	95,36
230	540116320	22,94	540116773	106,92
410	540116322	40,78	540107586	213,42
510	540116752	50,76	540116779	260,86

Samocentrický systém upínania určený pre štvorstranné frézovačky a tradičné stroje.



PLANŽETOVÝ SYSTÉM - BARKE

L	2 x oporný nôž + 2x nôž HSS SET		HSS nôž		M42 nôž	
	Nr	€	Nr	€	Nr	€
300	112B01000300-2	43,00	112B00100300	8,60	112B00200300	19,20
310	112B01000310-2	47,00	112B00100310	9,00	112B00200310	21,80
410	112B01000410-2	53,00	112B00100410	11,64	112B00200410	24,05
510	112B01000510-2	63,00	112B00100510	13,35	112B00200510	29,80

Systém oporného noža a noža určený na nahradenie tradičných hoblňovacích nožov. Obojstranné nože so špeciálnou geometriou výrazne redukovávajú rezný odpor, čím umožňujú väčšie hodnoty úberov aj pre menej výkonné stroje. Obrobený povrch je zároveň aj výrazne kvalitnejší.

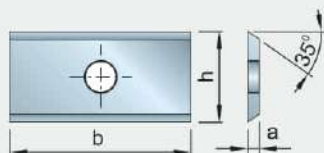

ŠTANDARDNÉ ŽILETKY S JEDNÝM OTVOROM



HW

b x h x a	MDF, DTD	€	MASÍV	€	UNIVERSAL	€
7,5x12x1,5	54013811	1,42	54013963	1,42	54012001	1,28
9x12x1,5					54012043	2,32
9,6x12x1,5	54013850	1,78	54014010	1,78	54012015	1,65
10x12x1,5					54013165	5,08
11x12x1,5					54013168	3,32
11,6x12x1,5					54013183	3,46
15x12x1,5	54013819	1,76	54013972	1,76	54012003	1,50
18x12x1,5					54013174	4,44
20x12x1,5	54013823	2,00	54013977	2,00	54012004	1,76
25x12x1,5	54013853	2,62	54014013	2,62	54012025	2,28

ŠTANDARDNÉ ŽILETKY S DVOMA OTVORMI



HW

b x h x a	MDF, DTD	€	MASÍV	€	UNIVERSAL	€
25x12x1,5	54013843	2,62	54014001	2,62	54012011	2,28
30x12x1,5	54013828	2,00	54013982	2,50	54012005	2,20
35x12x1,5					54013208	5,10
40x12x1,5	54013847	2,98	54014006	2,98	54012014	2,66
50x12x1,5	54013834	3,50	54013987	3,50	54012006	2,98
60x12x1,5	54013839	4,12	54013994	4,12	54012007	3,58

ŠTANDARDNÉ ŽILETKY S DVOMA OTVORMI PERFORMANCE

HWC

b x h x a	POVLAKOVANÉ	€
30x12x1,5	606Z055008NKD	10,62
50x12x1,5	606Z055010NKD	12,01

Diamantový povlak. Predĺženie životnosti oproti štandardným žiletkám až 5 násobne.

ZOŠIKMENÉ ŽILETKY S DVOMA OTVORMI



HW

b x h x a	UNIVERSAL	€
30x12x1,5 RH	54013437	4,80
30x12x1,5 LH	54013442	4,80
50x12x1,5 RH	54013438	5,56
50x12x1,5 LH	54013443	5,56

OBDĽŽNIKOVÉ ŽILETKY - ŠTVORSTRANNE BRÚSENÉ, S DVOMA OTVORMI



HW

b x h x a	MDF, DTD	€	MASÍV	€	UNIVERSAL	€
29,5x12x1,5	54013952	3,56	54014088	3,56	54013507	3,08
49,5x9x1,5	54013956	4,78			54013517	4,16
49,5x12x1,5	54013957	4,78	54014090	4,78	54013520	4,16

OBDĽŽNIKOVÉ ŽILETKY - ŠTVORSTRANNE BRÚSENÉ, S TROMI OTVORMI



HW

b x h x a	MDF, DTD	€	MASÍV	€	UNIVERSAL	€
50x9x1,5	54035425	9,06			54016950	7,86
50x12x1,7	54013866	5,50	54014030	5,50	54013327	4,78

HOBLŮVACIE ŽILETKY S DVOMA OTVORMI



HW

b x h x a	MDF, DTD	€	MASÍV	€	UNIVERSAL	€
80x13x2,2	54013841	14,42	54013997	14,42	540106831	13,82
100x13x2,2	54030831	20,44	54013998	20,44	540106832	19,52
120x13x2,2	54030832	24,86	54013999	24,86	540106833	23,76

ŽILETKY PRE ELEKTRICKÉ RUČNÉ HOBLÍKY



HW

b x h x a	MASÍV	€
82x5,5x1,1	54013020	2,83

ŽILETKY S KRÍŽOVÝM FIXAČNÝM VÝBRUSOM



HW

b x h x a	MDF, DTD	€	UNIVERSAL	€
30x5,5x1,1	54013914	3,50	54013397	2,98
50x5,5x1,1	54013918	4,50	54013401	3,90

ŽILETKY WERSOFIX - TIN POVLAKOVANÉ



HWC

b x h x a	MDF, DTD	€	MASÍV	€
20x5,5x1,1	54049525	8,60	54049526	8,62
30x6,5x1,1	540101074	8,00	540101075	8,00
50x10x1,1	54014277	10,86	54030843	10,86

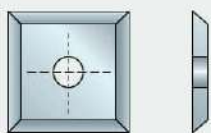

ŠTVORCOVÉ ŽILETKY - ŠTVORSTRANNE BRÚSENÉ



HW

b x h x a	MDF, DTD	€	MASÍV	€	UNIVERSAL	€
12x12x1,5	54013815	1,80	54013968	1,80	54012002	1,34
17x17x2	54013864	3,86	54030830	3,64	54013265	3,34
19x19x2					54013264	5,94

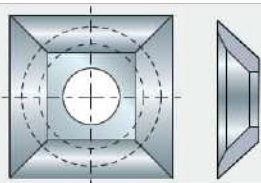

ŠTVORCOVÉ ŽILETKY PRE HOBLOVACIE HLAVY "HUNDEGGER"

HW

b x h x a	MDF, DTD	€	MASÍV	€
21x21x5,5			54022695	8,08

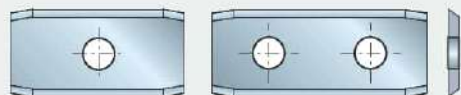

OBDLŽNIKOVÉ ŽILETKY PRE ŠPIRÁLOVÉ HOBLOVACIE HLAVY - ZRAZENÉ



HW

b x h x a	MDF, DTD	€	MASÍV	€	UNIVERSAL	€
24x12x1,5	s jedným otvorom		54041060	4,24	540104119	3,68
30x12x1,5	s dvoma otvormi		54013984	4,22	540112875	3,68

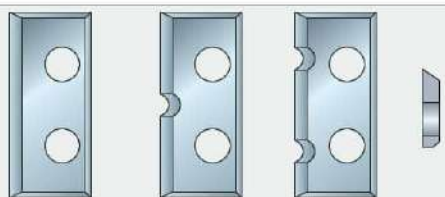

ŽILETKY PRE DLABACIE CNC FRÉZY



HW

b x h x a	MDF, DTD	€	MASÍV	€	UNIVERSAL	€
16x7x1,5 hladká					54016934	4,70
16x7x1,5 s jednou drážkou					54048995	7,82
16x7x1,5 s dvoma drážkami					54048996	7,38



ŠTVORCOVÉ ŽILETKY - PREDREZY



HW

b x h x a	MDF, DTD	€	MASÍV	€	UNIVERSAL	€
14x14x1,2					54013295	1,56
14x14x2	54013865	1,80	54014028	1,92	54013260	1,42



ŠTVORCOVÉ ŽILETKY - PREDREZY PERFORMANCE

HWC

b x h x a	POVLAKOVANÉ	€
14x14x2	606Z055007NKD	9,00

Diamantový povlak. Predĺženie životnosti oproti štandardným žiletkám až 5 násobne.

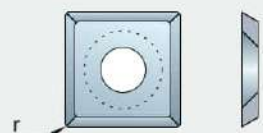

ŠTVORCOVÉ ŽILETKY PRE ŠPIRÁLOVÉ HOBLOVACIE HLAVY S ROHOVÝM RÁDIUSOM



HW

b x h x a	MDF, DTD	€	MASÍV	€
14x14x2			540104117	2,88

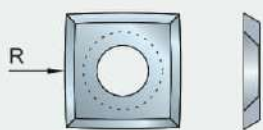

RÁDIUSOVÉ ŠTVORCOVÉ ŽILETKY PRE ŠPIRÁLOVÉ HOBLOVACIE HLAVY



HW

b x h x a	MDF, DTD	€	MASÍV	€
15x15x2,5 R100			540101180	4,00
15x15x2,5 R150			540100791	3,40

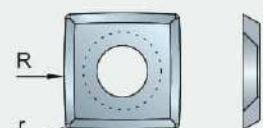

RÁDIUSOVÉ ŠTVORCOVÉ ŽILETKY PRE ŠPIRÁLOVÉ HOBLOVACIE HLAVY S ROHOVÝM RÁDIUSOM



HW

b x h x a	MDF, DTD	€	MASÍV	€
15x15x2,5 R50			54043895	3,44

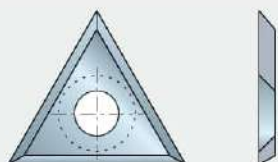

TROJUHOLNÍKOVÉ ŽILETKY - PREDREZY



HW

b x h x a	MDF, DTD	€	UNIVERSAL	€
22x19x2			54013271	4,16

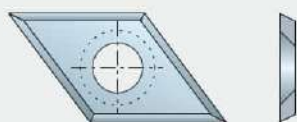

KOSOŠTVORCOVÉ ŽILETKY - PREDREZY



HW

b x h x a	MDF, DTD	€	UNIVERSAL	€
14x28x2			54013258	4,36

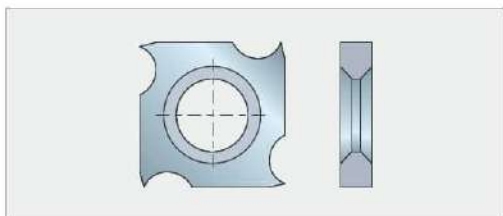

DRÁŽKOVACIE ELEMENTY - ŠTVORBRITÉ



HW

b x h x a	UNIVERSAL	€
18x18x1,95	54013293	4,30
18x18x2,45	54013291	4,84
18x18x2,95	54013305	7,56
18x18x3,7	54013289	9,24

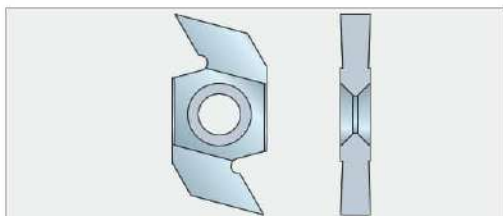

DRÁŽKOVACIE ELEMENTY - DVOJBRITÉ



HW

b x h x a	UNIVERSAL	€
34x16x3	54013277	17,70
34x16x4	54013278	18,86
34x16x5	54013279	20,92
34x16x6	54013280	30,06
34x16x7	54013281	30,06

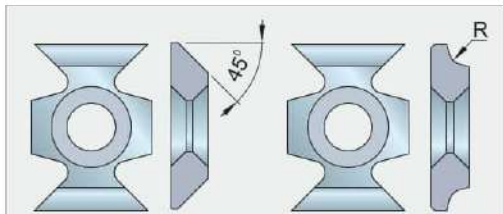

ZAOBĽOVACIE A ZRÁŽACIE ELEMENTY JEDNOSTRANNÉ



HW

b x h x a	MASÍV	€
16x22x5 R=1,5	54032294	12,26
16x22x5 R=2	54032295	12,26
16x22x5 R=2,5	54032296	12,26
16x22x5 R=3	54032297	12,26
16x22x5 R=4	54032299	12,26
16x22x6 R=5	54032301	13,42
16x22x5 45°	54032292	12,26

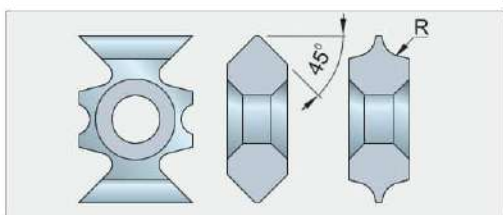

ZAOBĽOVACIE A ZRÁŽACIE ELEMENTY OBOJSTRANNÉ



HW

b x h x a	MASÍV	€
15x20x7 R=1,5	54032310	85,96
15x20x7,3 R=2	54032308	85,96
15x22,3x9 R=3	54032306	85,96
15x20x8 45°	54032304	70,56

Y200
MAGNETICKÝ USTAVOVAČ NOŽOV

ø D	Nr	€
80	606Y200080N	63,90
100	606Y200100N	63,90
120	606Y200120N	63,90

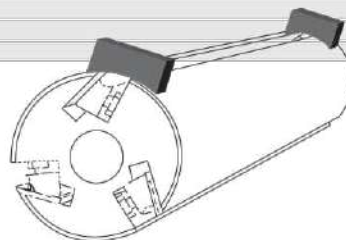

Silný magnet fixuje ustavovač na hobľovacom valci. Pre každý priemer valca používajte samostatný ustavovač.

BARKE
UNIVERZÁLNY USTAVOVAČ NOŽOV

ø D	Nr	€
127	112B8250180	91,00

Rekifikačná skrutka

Magnet

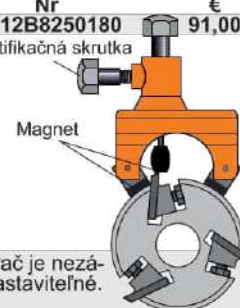

Univerzálny nastavovač hobľovacích nožov vo valcoch. Ustavovač je nezávislý na priemere valcov. Vysunutie hobľovacích nožov je prednastaviteľné. V cene je dvojica ustavovačov.

CALIBRE
KALIBROVACÍ USTAVOVAČ NOŽOV

ø D	Nr	€
35	2492017031	195,50
40	2492017032	195,50

Univerzálny nastavovač hobľovacích valcov. Pre valce s upínacím otvorom 35 a 40mm a priemery 100 až 180mm. Nastavenie nožového pravítka umožňuje aj uhlovú korekciu pri odchýlke hriadeľa voči stolu stroja.



PÍLOVÉ KOTÚČE



eshop.woodb.sk



STROJE

NÁSTROJE

NÁRADIE

KOVANIE

CHÉMIA

SPOJOVACÍ MATERIAL

DIELŇA

DOM-ZÁHRADA

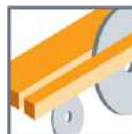
*Kotúče na lamino*

3.4 , 3.11 , 3.13

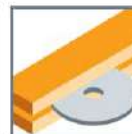
*Kotúče drážkovacie*

3.19

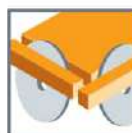
*Kotúče univerzálne*

3.3 , 3.10

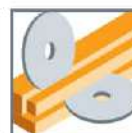
*Kotúče pre uhlové píly*

3.2 , 3.8

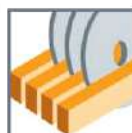
*Kotúče rozmietačie*

3.1 , 3.7

*Kotúče stavebné*

3.5

*Kotúče na elektrické
nástroje*

3.6 , 3.17

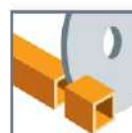
*Kotúče na
hliník a kovy*

3.5

*Kotúče na nárezové
centrá*

3.14

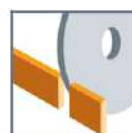
*Kotúče na plasty*

3.12

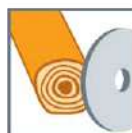
*Kotúče na palivové
drevo*

3.2 , 3.5 , 3.9

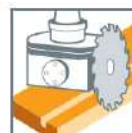
*Kotúče pre obrábacie
centrá*

3.19

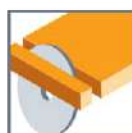
*Kotúče na masív
priečne*

3.4 , 3.10

*Príslušenstvo*

3.19

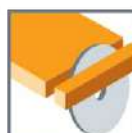
*Kotúče na masív
pozdĺžne*

3.2

*Kotúče ostríme
v najvyššej kvalite*

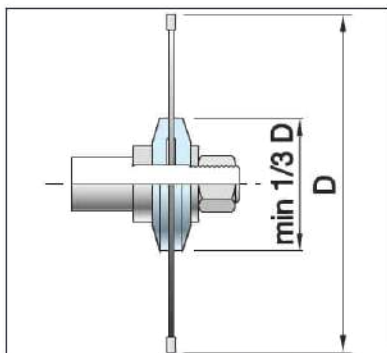

Mínimálny priemer prírub

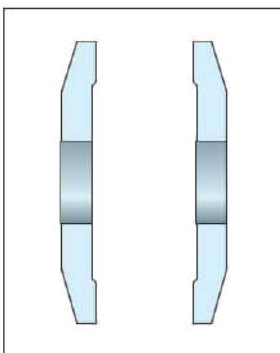

Presnosť prírub

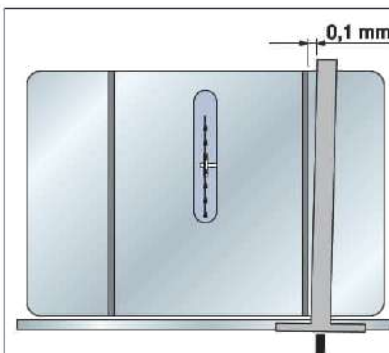

„Otvorené“ paralelné pravítko

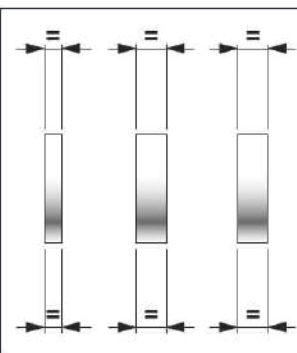

Rovnoběžnosť medzikružkov

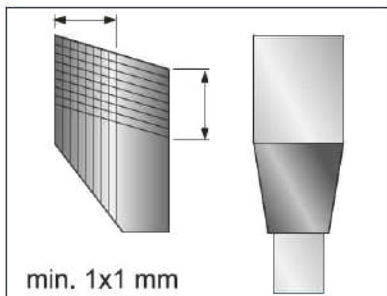

min. 1x1 mm

Počet ostrení

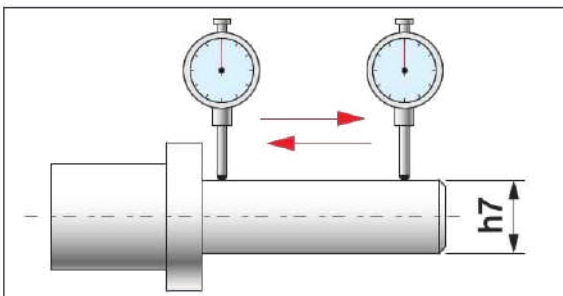

Presnosť hriadeľa a otvoru pílového kotúča

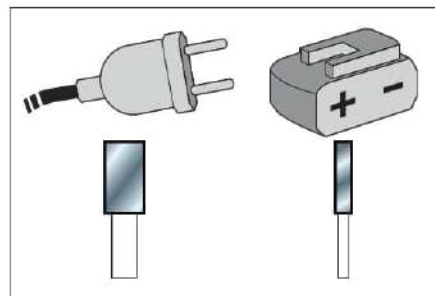

Znižovanie merného rezného odporu

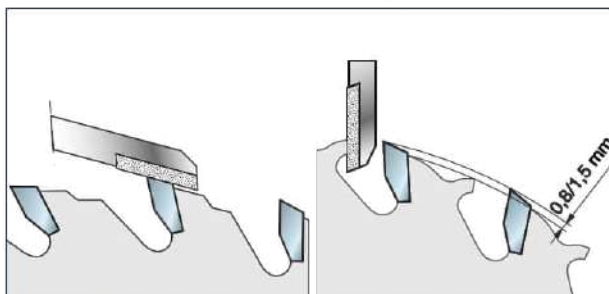

Ostrenie pílových kotúčov s obmedzovačom

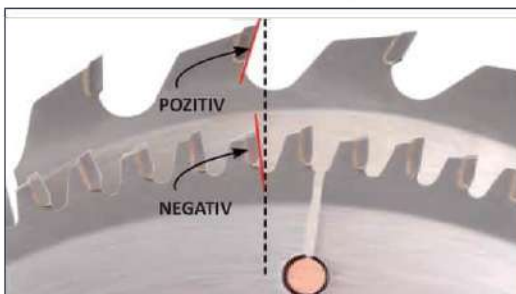

Pozitívna - negatívna geometria



Kvalita rezaného povrchu obrobku



Čistenie kotúčov PULITOOLOM

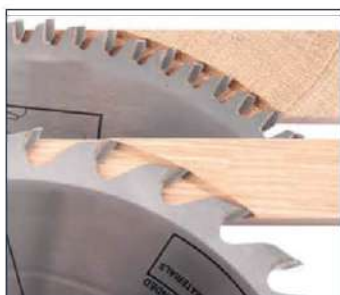

Pozdĺžne - priečne rezanie masívu

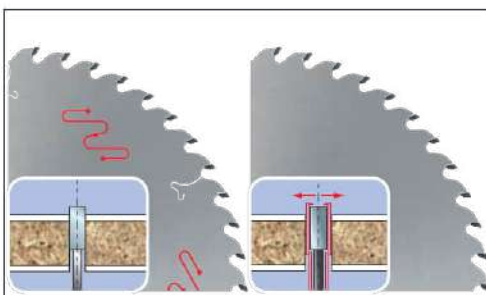

Antivibračné otvory v tele kotúča

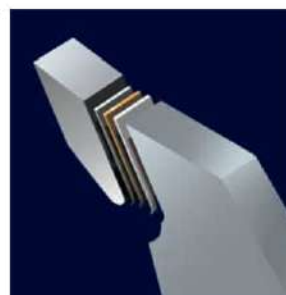

Navarenie plátky na telo kotúča

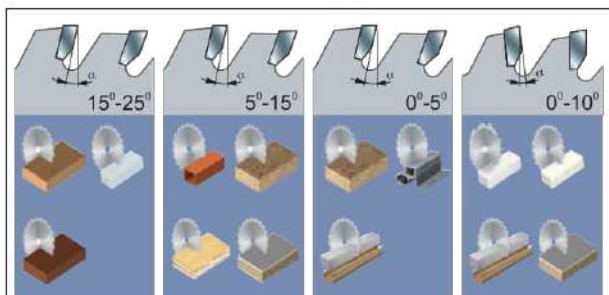

Uhol čela

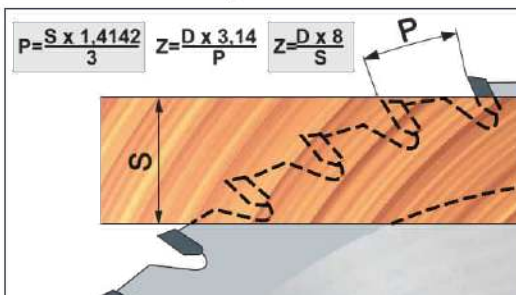

Závislosť hrúbky obrobku na počte zubov

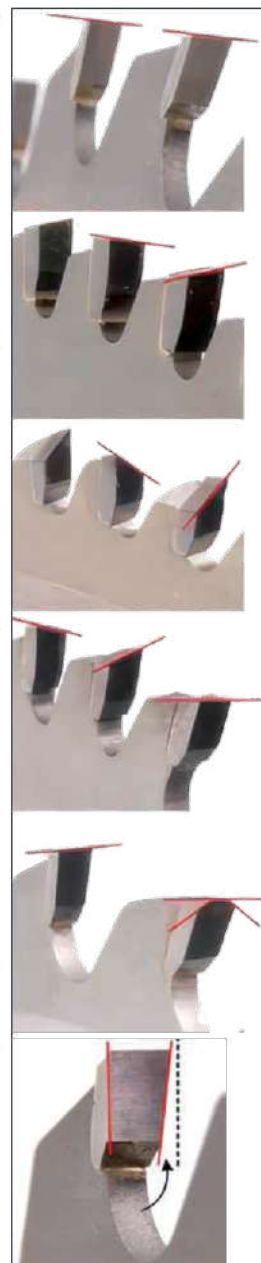

Tvar zuba





5394 FZ						HW	
ROZMIETACIE PÍLOVÉ KOTÚČE - 2 VYHADZOVAČE							
ø D	B	b	ø d	Z	Nr	€	
250	3,6	2,5	70 DKN	16+2	22194000250	53,28	
250	3,6	2,5	80 DKN	16+2	22194000251	53,28	
300	4	2,8	30	18+2	22194000300	65,20	
300	4	2,8	70 DKN	18+2	22194000301	65,20	
300	4	2,8	80 DKN	18+2	22194000302	65,20	
315	4	2,8	80 DKN	18+2	22194000315	68,33	
350	4	2,8	70 DKN	20+2	22194000350	77,27	
350	4	2,8	80 DKN	20+2	22194000351	77,27	
400	4	2,8	80 DKN	24+2	22194000400	94,00	



Rozmietacie pílové kotúče, štandardná kvalita rezu. Určené pre nižšie výšky rezu.

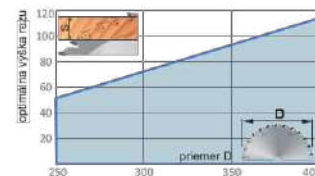

5394.1 FZ						HW	
ROZMIETACIE PÍLOVÉ KOTÚČE - 4 VYHADZOVAČE							
ø D	B	b	ø d	Z	Nr	€	
300	3,2	2,2	80 DKN	18+4	22194100300	66,60	
300	3,2	2,2	80 DKN	24+4	22194100301	66,60	
315	3,2	2,2	80 DKN	18+4	22194100315	79,13	
400	4	2,8	80 DKN	24+4	22194100401	92,30	
450	4,4	3,2	80 DKN	20+4	22194100450	98,10	
450	4,4	3,2	80 DKN	28+4	22194100451	116,80	
500	4,4	3,2	30	22+6	22194100500	158,53	
550	5	3,5	30	32+6	22194100550	215,27	



Rozmietacie pílové kotúče, štandardná kvalita rezu. Určené pre stredné výšky rezu.

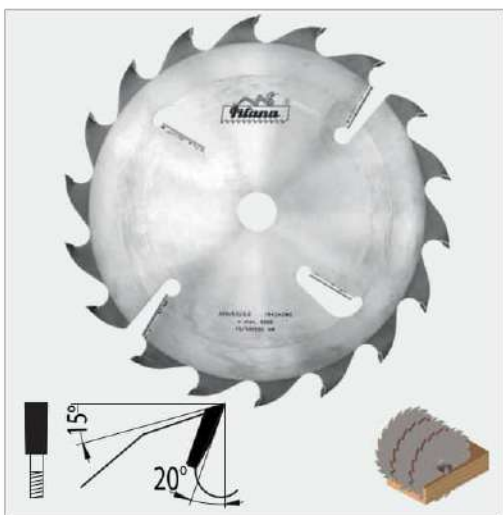
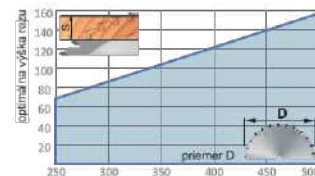

5394.1 MASSIVE FZ						HW	
ROZMIETACIE PÍLOVÉ KOTÚČE - STABIL							
ø D	B	b	ø d	Z	Nr	€	
300	4	2,8	30	18+2	221941M0300	77,90	
300	4	2,8	70 DKN	18+2	221941M0301	77,90	
300	4	2,8	80 DKN	18+2	221941M0302	77,90	
315	4	2,8	80 DKN	18+2	221941M0315	79,13	
350	4	2,8	30	20+4	221941M0350	83,40	
350	4	2,8	70 DKN	20+4	221941M0351	83,40	
350	4	2,8	80 DKN	20+4	221941M0352	83,40	
400	4,2	3	30	20+4	221941M0400	85,50	
400	4,2	3	80 DKN	20+4	221941M0401	99,27	
450	5	3,5	30	20+4	221941M0450	131,27	
500	5	3,5	30	22+6	221941M0500	149,50	
550	5,5	3,5	30	22+6	221941M0550	192,70	



Zosilnené rozmietacie pílové kotúče, štandardná kvalita rezu. Určené pre vyššie výkony a náročnejšie typy rezania.

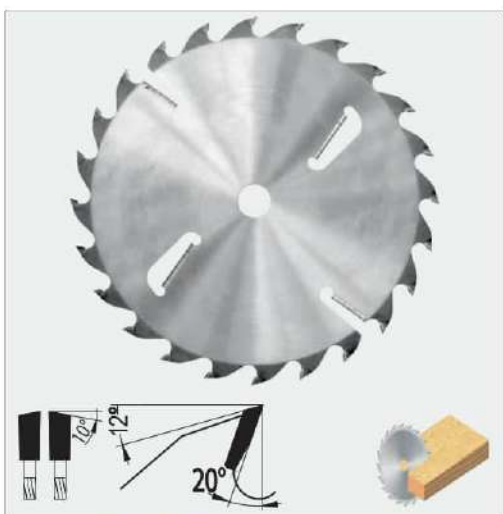
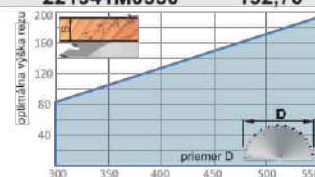

320 WZ						HW	
ROZMIETACIE PÍLOVÉ KOTÚČE PRE STOLOVÉ PÍLY							
ø D	B	b	ø d	Z	Nr	€	
250	3,2	2,2	30	20+2	6150320253020	56,80	
300	3,2	2,2	30	24+4	6150320303024	64,80	
350	3,5	2,5	30	28+4	6150320353028	83,20	
400	4	2,8	30	32+6	6150320403032	117,60	



Rozmietacie pílové kotúče určené pre jednokotúčové píly. Vhodné na omietanie reziva na formátovacích pilách. Vyššia kvalita rezu.

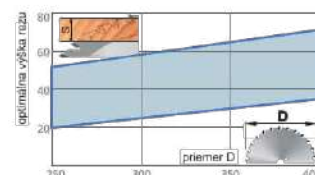

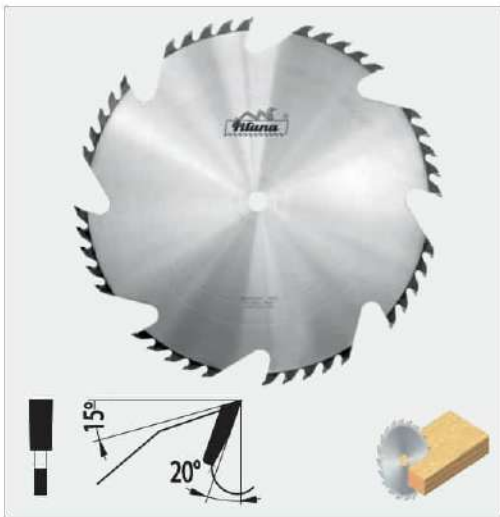

5333.1 FZ PÍLOVÉ KOTUČE HANIBAL						HW		
ø D	B	b	ø d	Z	Nr	€		
600	5,5	3,5	30	8x5	22133100600	231,67		
700	5,5	3,5	35	8x5	22133100700	288,87		
800	6,5	4,5	35	8x5	22133100800	368,40		

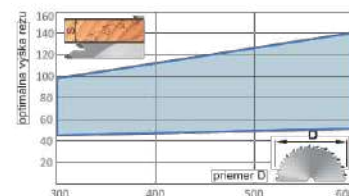

Rozmietacie pilové kotúče, štandardná kvalita rezu. Určené pre väčšie hrúbky materiálu.

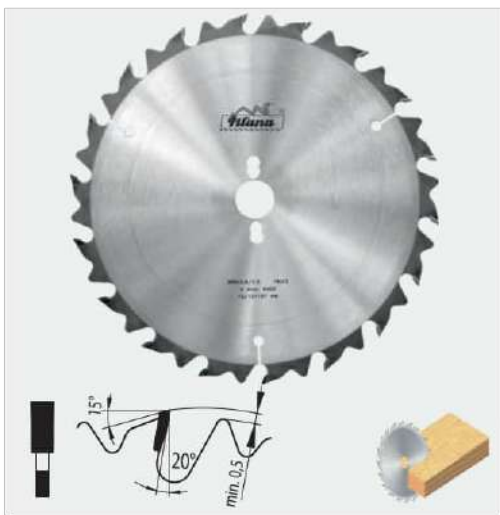

5383-55 LFZ PÍLOVÉ KOTUČE NA POZDĽŽNE REZANIE MASÍVU						HW		
ø D	B	b	ø d	Z	Nr	€		
300	3,6	2,5	20	18	22183550300	35,33		
350	4	2,8	30	20	22183550350	46,67		
400	4	2,8	30	24	22183550400	57,33		
600	4,2	2,8	30	36	22183550600	122,73		

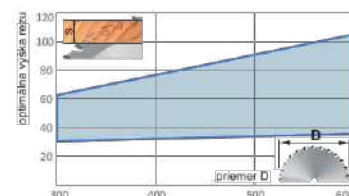

Pozdĺžne rezanie masívu. Konštrukcia kotúča je s obmedzovačom triesky.



5383-35 LWZ KOTUČE NA POZDĽŽNE A PRIEČNE REZANIE MASÍVU						HW		
ø D	B	b	ø d	Z	Nr	€		
250	3,2	2,2	30	24	22183350250	33,27		
300	3,2	2,2	30	28	22183350300	41,00		
350	3,6	2,5	30	32	22183350350	49,13		
400	3,6	2,5	30	36	22183350400	58,60		
450	4	2,8	30	40	22183350450	74,93		
500	4	2,8	30	44	22183350500	87,27		
600	5,2	3,5	30	54	22183350600	155,07		

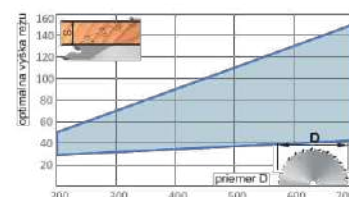

Pozdĺžne a priečne rezanie masívu. Konštrukcia kotúča je s obmedzovačom triesky.



5380-40 FZ PÍLOVÉ KOTUČE NA POZDĽŽNE REZANIE MASÍVU						HW		
ø D	B	b	ø d	Z	Nr	€		
200	2,5	1,6	20	16	22180400200	23,33		
250	3,2	2,2	30	20	22180400250	32,40		
300	3,2	2,2	30	24	22180400300	40,20		
350	3,6	2,5	30	28	22180400350	47,47		
400	3,6	2,5	30	32	22180400400	59,13		
450	4	2,8	30	36	22180400450	72,73		
500	4	2,8	30	40	22180400500	85,33		
600	5,5	3,5	30	48	22180400600	201,73		
700	5,5	3,5	35	56	22180400700	258,00		

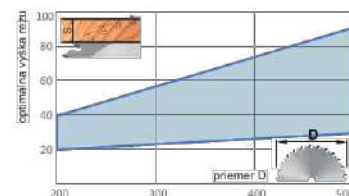

Pozdĺžne rezanie masívu väčších hrúbok na stolových kotúčových pilách.





5381-26 WZ		PÍLOVÉ KOTUČE NA POZDĹŽNE REZANIE MASÍVU		HW		
ø D	B	b	ø d	Z	Nr	€
250	3,2	2,2	30	32	22181260250	34,80
300	3,2	2,2	30	36	22181260300	42,07
350	3,6	2,5	30	40	22181260350	57,13
400	3,6	2,5	30	48	22181260400	66,67
450	4	2,8	30	56	22181260450	86,67
500	4	2,8	30	64	22181260500	102,07

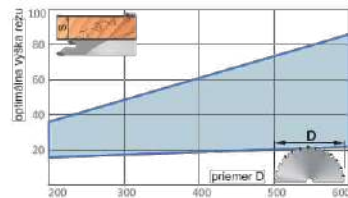

Pozdĺžne rezanie masívu, preglejky, bidosky a aglomerovaných materiálov.



5381-20 WZ		PÍLOVÉ KOTUČE NA UNIVERZÁLNE POUŽITIE		HW		
ø D	B	b	ø d	Z	Nr	€
250	3,2	2,2	30	40	22181200250	40,33
300	3,2	2,2	30	48	22181200300	49,00
350	3,6	2,5	30	54	22181200350	63,80
400	3,6	2,5	30	64	22181200400	70,07
450	4	2,8	30	72	22181200450	92,93
500	4	2,8	30	84	22181200500	110,20
600	5,2	3,5	30	90	22181200600	199,87

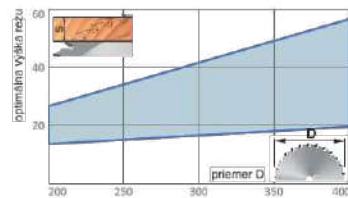

Pozdĺžne a priečne rezanie masívu, preglejky, bidosky, termoplastov a aglomerátov.



5381-16 WZ		PÍLOVÉ KOTUČE NA UNIVERZÁLNE POUŽITIE		HW		
ø D	B	b	ø d	Z	Nr	€
250	3,2	2,2	30	48	22181160250	45,07
300	3,2	2,2	30	64	22181160300	52,67
350	3,6	2,5	30	72	22181160350	67,87
400	3,6	2,5	30	84	22181160400	89,93

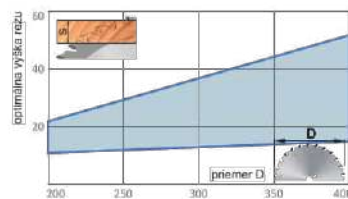

Priečne a pozdĺžne rezanie masívu, preglejky, bidosky a aglomerovaných materiálov.



5381-13 WZ		PÍLOVÉ KOTUČE NA UNIVERZÁLNE POUŽITIE		HW		
ø D	B	b	ø d	Z	Nr	€
250	3,2	2,2	30	64	22181130250	45,20
300	3,2	2,2	30	72	22181130300	54,67
350	3,6	2,5	30	84	22181130350	66,13
400	3,6	2,5	30	96	22181130400	78,40

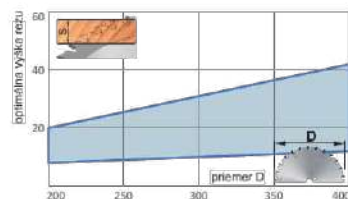

Priečne a pozdĺžne rezanie masívu, preglejky, bidosky a aglomerovaných materiálov.





5381-11 WZ HW  
PÍLOVÉ KOTUČE NA UNIVERZÁLNE POUŽITIE

ø D	B	b	ø d	Z	Nr	€
250	3,2	2,2	30	72	22181110250	50,80
300	3,2	2,2	30	96	22181110300	67,27
350	3,6	2,5	30	108	22181110350	77,20
400	3,6	2,5	30	120	22181110400	89,47



Rezanie preglejky a aglomerovaných materiálov. Skracovanie masívu.



5390 DHZ HW  
PÍLOVÉ KOTUČE PRE FORMÁTOVACIE PÍLY - DUTÝ ZUB

ø D	B	b	ø d	Z	Nr	€
220	3,2	2,5	30	42	22190DZ0220	71,73
250	3,2	2,8	30	48	22190DZ0250	82,00
303	3,2	2,8	30	60	22190DZ0303	102,73
350	3,6	2,8	30	72	22190DZ0350	125,13



Pilové kotúče na rezanie laminovaných alebo dýhovaných materiálov. Vysoká kvalita rezu bez potreby použitia predrezávacieho kotúča.



5397-11 TFZ HP HW  
KOTUČE PRE FORMÁTOVACIE PÍLY - HIGH PROF

ø D	B	b	ø d	Z	Nr	€
250	3,2	2,2	30	80	22197110250	68,87
300	3,2	2,2	30	96	22197110300	83,67
350	3,6	2,5	30	108	22197110350	102,87



Pilové kotúče na rezanie laminovaných, dýhovaných materiálov a exotických drevín. Zvýšená tuhosť a presnosť tela pilového kotúča.



5381-OPTI WZ HW  
PÍLOVÉ KOTUČE PRE OPTIMALIZAČNÉ PÍLY

ø D	B	b	ø d	Z	Nr	€
400	3,8	2,8	30	60	221810P0400	94,67
400	4,5	3,2	30	120	221810P0401	127,27
450	4,8	3,5	30	138	221810P0450	159,07
500	5	3,2	30	96	221810P0500	152,67
500	5,2	3,2	30	120	221810P0501	160,33
500	4,8	3,5	30	144	221810P0502	174,20
550	4,8	3,5	30	144	221810P0550	190,20
600	5,8	4	30	120	221810P0600	256,53
600	5,4	4	30	172	221810P0601	296,67



Priečne delenie masívu. Konštrukcia pilového kotúča je určená pre optimalizačné píly.





5387 TFZ P						HW	
PÍLOVÉ KOTÚČE NA NEŽELEZNÉ KOVY - TRAPÉZ POZ.							
ø D	B	b	ø d	Z	Nr	€	
200	3,2	2,5	30	48	2218711P200	43,30	
250	3,2	2,5	30	60	2218711P250	54,30	
300	3,2	2,5	30	96	2218711P300	86,80	
350	3,6	2,8	30	108	2218711P350	98,73	
400	3,6	2,8	30	96	2218711P400	99,00	

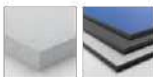

Určené na hliník, plast, HPL dosky. Rezanie plyných materiálov. Strojný posuv.



5387 TFZ N						HW	
PÍLOVÉ KOTÚČE NA NEŽELEZNÉ KOVY - TRAPÉZ NEG.							
ø D	B	b	ø d	Z	Nr	€	
200	3,2	2,5	30	60	2218711N200	52,20	
250	3,2	2,5	30	80	2218711N250	71,13	
300	3,2	2,5	30	96	2218711N300	86,80	
350	3,6	2,8	30	108	2218711N350	98,73	
400	3,6	2,8	30	120	2218711N400	113,73	



Určené na hliník, plast, HPL dosky. Rezanie tenkostenných materiálov. Vhodné aj na ručný posuv.



5388 WZ/FA - DRY CUT						HW	
PÍLOVÉ KOTÚČE NA OCEĽ A KOMPOZIT							
ø D	B	b	ø d	Z	Nr	€	
200	2,4	1,8	30	40	22188WF0200	39,33	
216	2,4	1,8	30	40	22188WF0216	40,33	
250	2,4	2	30	48	22188WF0250	51,40	
300	2,4	2	30	60	22188WF0300	61,33	
300	2,4	2	30	80	22188WF0301	74,33	
305	2,4	2	30	80	22188WF0305	74,80	
350	2,6	2	30	80	22188WF0350	85,10	

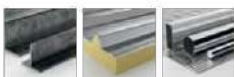

Určené na abrazívne materiály, tenkostenné oceľové profily, sendvičové materiály.



5388 TZ						HW	
PÍLOVÉ KOTÚČE NA STAVEBNÉ MATERIÁLY							
ø D	B	b	ø d	Z	Nr	€	
250	3,2	2,2	30	18	22188TZ0250	27,47	
300	3,2	2,2	30	20	22188TZ0300	33,67	
350	3,6	2,5	30	24	22188TZ0350	48,33	
400	3,6	2,5	30	28	22188TZ0400	55,80	
450	4	2,8	30	32	22188TZ0450	71,40	
500	4	2,8	30	36	22188TZ0500	84,40	
600	5,2	3,8	30	42	22188TZ0600	162,07	



Určené na stavebné materiály - heraklít, pórobetón, stavebné bednenie.



5391 WZ - EN		POZDĽŽNÉ REZANIE		HW		
KOTUČE PRE RUČNÉ KOTUČOVÉ PÍLY						
ø D	B	ø d	Z	Nr	€	
127	2,6	20	10WZ	221EN012701	13,47	
130	2,6	20	10WZ	221EN013001	14,27	
130	2,6	20	20WZ	221EN013002	18,87	
134	2,6	20	10WZ	221EN013401	13,30	
140	2,6	20	10WZ	221EN014002	14,40	
140	2,6	20	20WZ	221EN014003	19,33	
150	2,6	20	12WZ	221EN015001	15,80	
150	2,6	20	24WZ	221EN015002	19,60	
156	2,6	12,75	24WZ	221EN015601	24,00	
160	2,6	20	12WZ	221EN016001	16,13	
160	2,5	20	16WZ	221EN016002	17,87	
160	2,8	20	18WZ	221EN016003	24,70	
160	2,6	20	24WZ	221EN016004	20,48	
170	2,6	30	12WZ	221EN017001	17,13	
170	2,6	30	24WZ	221EN017002	20,53	
180	2,6	30	12 WZ	221EN018001	17,13	
180	2,5	20	20WZ	221EN018002	20,80	
180	2,5	20	28WZ	221EN018003	25,00	
184	2,6	30	12WZ	221EN018401	17,13	
184	2,6	30	24WZ	221EN018402	21,48	
190	2,6	16	14WZ	221EN019001	18,73	
190	2,6	30	14WZ	221EN019002	18,73	
190	2,6	30	24WZ	221EN019003	22,28	
190	2,6	30	30WZ	221EN019004	25,40	
200	2,5	20	16FZ	221EN020001	23,33	
200	2,8	30	16WZ	221EN020002	20,53	
200	2,5	20	24WZ	221EN020003	23,60	
200	2,8	30	30WZ	221EN020004	25,80	
200	2,5	20	32WZ	221EN020005	27,20	
210	2,8	30	18WZ	221EN021001	22,47	
210	2,8	30	32WZ	221EN021002	26,93	
216	2,8	30	24WZ	221EN021601	26,47	
230	2,8	30	20WZ	221EN023001	23,33	
230	2,8	30	34WZ	221EN023002	29,13	



Píllové kotúče určené na pozdĺžne rezanie.



5391 WZ - EN		PRIEČNÉ REZANIE		HW		
KOTUČE PRE RUČNÉ KOTUČOVÉ PÍLY						
ø D	B	ø d	Z	Nr	€	
127	2,6	20	36WZ	221EN012702	22,60	
140	2,6	20	42WZ	221EN014004	25,20	
150	2,6	20	48WZ	221EN015003	28,60	
160	2,5	20	36WZ	221EN016005	23,93	
160	2,5	20	48WZ	221EN016007	29,07	
160	2,6	20	48WZ	221EN016008	28,80	
180	2,5	20	36WZ	221EN018004	28,13	
180	2,6	30	40WZ	221EN018005	26,40	
180	2,5	20	56WZ	221EN018006	33,60	
190	2,6	30	56WZ	221EN019006	33,67	
200	2,5	20	40WZ	221EN020006	31,33	
200	2,8	30	40WZ	221EN020007	30,53	
200	2,5	20	48WZ	221EN020008	32,33	
200	3	30	48WZ	221EN020009	79,80	
200	2,5	20	64WZ	221EN020010	39,60	
200	2,8	30	64WZ	221EN020011	40,27	
210	2,8	30	40WZ	221EN021003	31,87	
210	2,8	30	64WZ	221EN021004	38,07	
210	2,8	30	48WZN	221EN021005	37,13	
216	2,8	30	48WZ	221EN021602	31,87	
230	2,8	30	64WZ	221EN023003	43,20	



Píllové kotúče na univerzálne použitie.



5391 TFZ - EN		LAMINO		HW		
KOTUČE PRE RUČNÉ KOTUČOVÉ PÍLY						
ø D	B	ø d	Z	Nr	€	
160	2,8	20	48TFZ	221EN016009	33,40	
160	2,8	30	48TFZN	221EN016010	37,27	
190	2,8	30	54TFZ	221EN019007	38,27	
190	2,8	30	56TFZN	221EN019008	44,50	

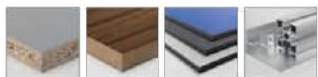

Píllové kotúče na laminované materiály a hliník.

5391 WZ/FA - EN		STAVBA		HW		
KOTUČE PRE RUČNÉ KOTUČOVÉ PÍLY						
ø D	B	ø d	Z	Nr	€	
150	2,2	20	30WZ/FA	221EN015004	28,73	
190	2,4	20	38WZ/FA	221EN019005	37,40	



Píllové kotúče na sendvičové materiály a stavebné rezivo.

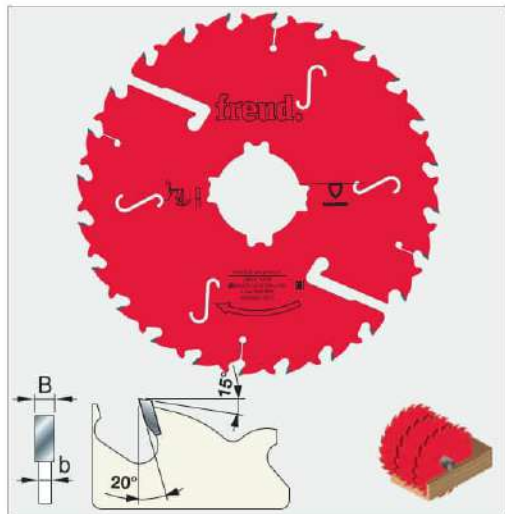

LM01 FZ		ROZMIETACIE PÍLOVÉ KOTÚČE - TENKÝ PREREZ		HW	frend	
ø D	B	b	ø d	Z	Nr	€
180	2,2	1,6	40 DKN	16+2	280LM010100	39,20
200	2,2	1,6	40 DKN	16+2	280LM010200	40,80
225	2,2	1,6	70 DKN	16+2	280LM010500	43,60
250	2,2	1,6	60 DKN	20+2	280LM010700	50,00
300	2,5	1,8	60 DKN	24+2	280LM011100	60,40
300	2,5	1,8	80 DKN	24+2	280LM011300	60,40



Kotúče vhodné do rozmietačiek a štvorstranných frézo-vačiek. Určené pre sušené rezivo s maximálnou vlhkosťou 10-12%.

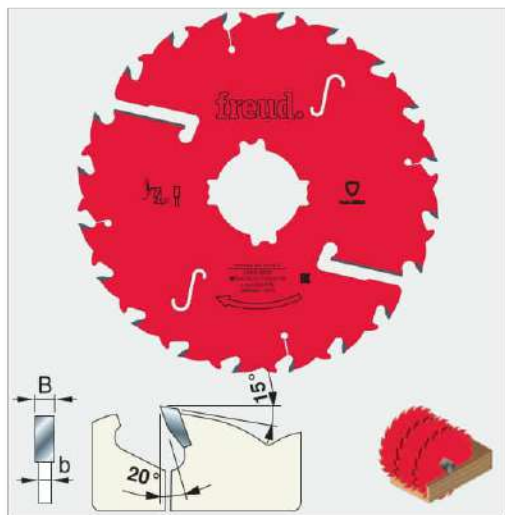
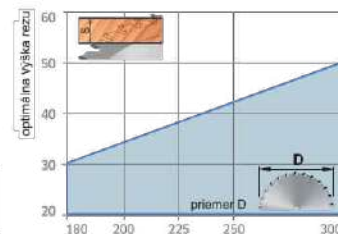

LM02 FZ		ROZMIETACIE PÍLOVÉ KOTÚČE - TENKÝ PREREZ		HW	frend	
ø D	B	b	ø d	Z	Nr	€
250	2,8	2	30 DKN	16+2	280LM020100	51,20
250	2,8	2	70 DKN	16+2	280LM020300	51,20
300	2,8	2	30 DKN	20+2	280LM020600	66,80
300	2,8	2	70 DKN	20+2	280LM020800	66,80
350	3	2,2	30 DKN	24+4	280LM021200	98,40



Kotúče vhodné do rozmietačiek a štvorstranných frézo-vačiek. Určené pre sušené rezivo s maximálnou vlhkosťou 15%.

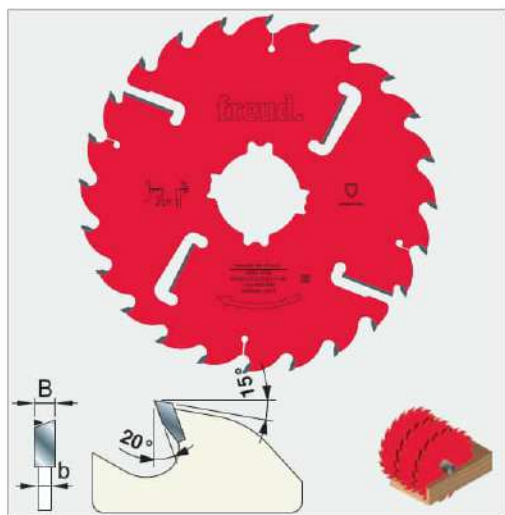
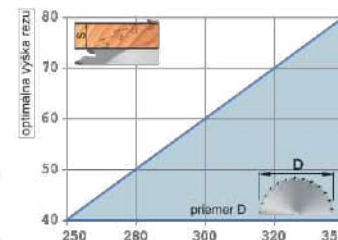

LM04 WZ		ROZMIETACIE PÍLOVÉ KOTÚČE - ŠTANDARD		HW	frend	
ø D	B	b	ø d	Z	Nr	€
250	3,2	2,2	70 DKN	20+4	280LM040300	67,20
250	3,2	2,2	80 DKN	20+4	280LM040400	67,20
300	3,2	2,2	70 DKN	24+4	280LM040700	78,40
300	3,2	2,2	80 DKN	24+4	280LM040800	82,00
350	3,5	2,5	70 DKN	24+6	280LM042400	107,60
350	3,5	2,5	80 DKN	24+6	280LM042500	107,60
400	4	2,8	70 DKN	28+6	280LM041600	130,80
400	4	2,8	80 DKN	28+6	280LM041700	130,80



Pílové kotúče do rozmietačiek. Určené pre sušené rezivo s maximálnou vlhkosťou do 15%.

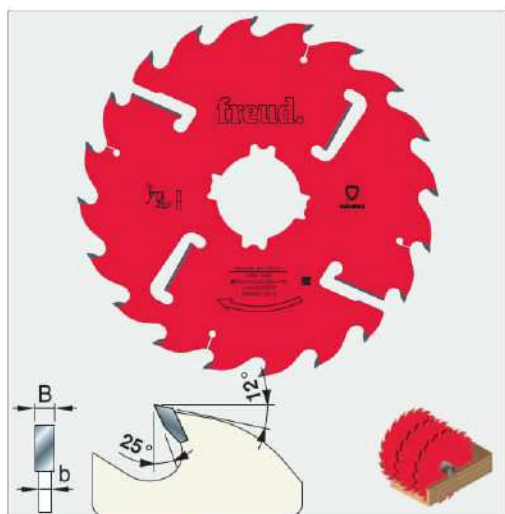
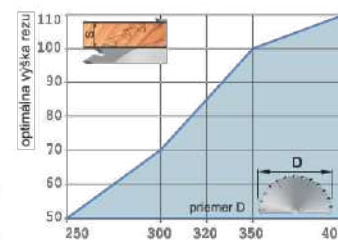

LM05 FZ		ROZMIETACIE PÍLOVÉ KOTÚČE - ŠTANDARD		HW	frend	
ø D	B	b	ø d	Z	Nr	€
250	3,4	2,2	30 DKN	16+4	280LM050100	65,20
300	3,4	2,2	30 DKN	20+4	280LM050500	79,20
300	3,4	2,2	70 DKN	20+4	280LM050700	79,20
300	3,4	2,2	80 DKN	20+4	280LM050800	79,20
350	3,7	2,5	30 DKN	20+6	280LM051100	104,00
350	3,7	2,5	70 DKN	20+6	280LM051400	104,00
350	3,7	2,5	80 DKN	20+6	280LM051500	104,00
400	4	2,8	30 DKN	24+6	280LM051900	128,00
400	4	2,8	80 DKN	24+6	280LM052100	128,00
450	4,4	3	30 DKN	24+6	280LM052400	190,40
500	4,8	3,5	30 DKN	28+6	280LM052900	244,00
500	4,8	3,5	30 DKN	28+6	280LM052901	244,00
500	4,8	3,5	50 DKN	28+6	280LM053000	244,00
550	4,8	3,5	30 DKN	28+6	280LM053400	277,60



Pílové kotúče do rozmietačiek. Určené na tvrdé aj mäkké dreveniny s vlhkosťou nad 10%.

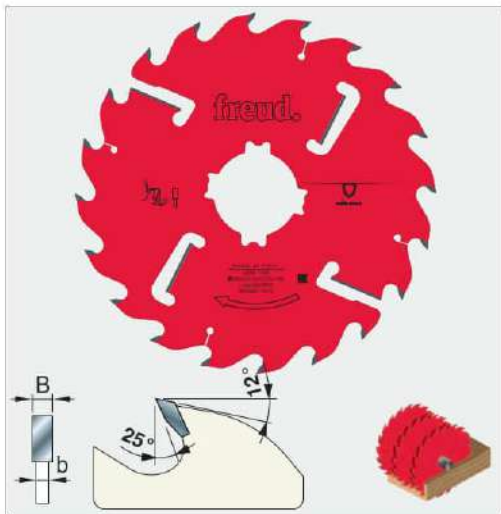

LM06 FZ					HW freud	
ROZMIETACIE PÍLOVÉ KOTUČE - STABIL						
ø D	B	b	ø d	Z	Nr	€
250	4,2	3	70 DKN	16+4	280LM060300	76,00
250	4,2	3	80 DKN	16+4	280LM060400	76,00
300	4,2	3	70 DKN	20+4	280LM060700	98,00
300	4,2	3	80 DKN	20+4	280LM060800	98,00
320	4,2	3	80 DKN	20+4	280LM061000	109,20
350	4,2	3	70 DKN	20+6	280LM061300	124,40
350	4,2	3	80 DKN	20+6	280LM061400	124,40



Pílové kotúče so zvýšenou stabilitou do rozmietačiek. Určené na tvrdé aj mäkké dreveny s vlhkosťou nad 10%.

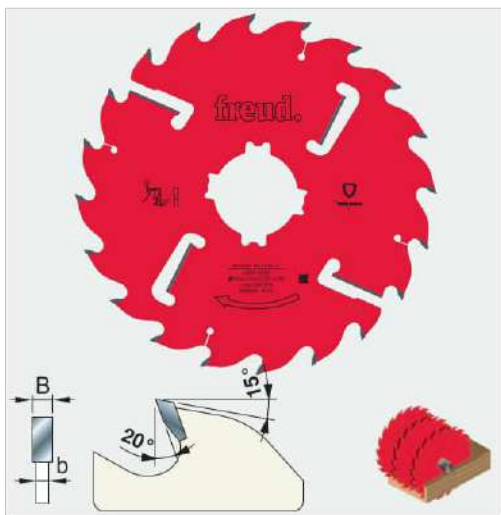
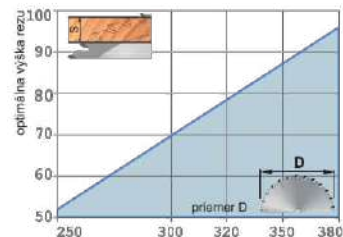

LM07 FZ					HW freud	
ROZMIETACIE PÍLOVÉ KOTUČE - KRAJOVÉ						
ø D	B	b	ø d	Z	Nr	€
250	5,5	3,5	70 DKN	16+4	280LM070300	129,60
250	5,5	3,5	80 DKN	16+4	280LM070400	129,60
300	5,5	3,5	70 DKN	20+4	280LM070700	136,80
300	5,5	3,5	80 DKN	20+4	280LM070800	136,80
320	5,5	3,5	80 DKN	20+4	280LM071000	149,60
350	5,5	3,5	70 DKN	24+6	280LM071300	165,20
350	5,5	3,5	80 DKN	24+6	280LM071400	165,20



Pílové kotúče so zvýšenou stabilitou do rozmietačiek. Určené na tvrdé aj mäkké dreveny s vlhkosťou nad 10%.

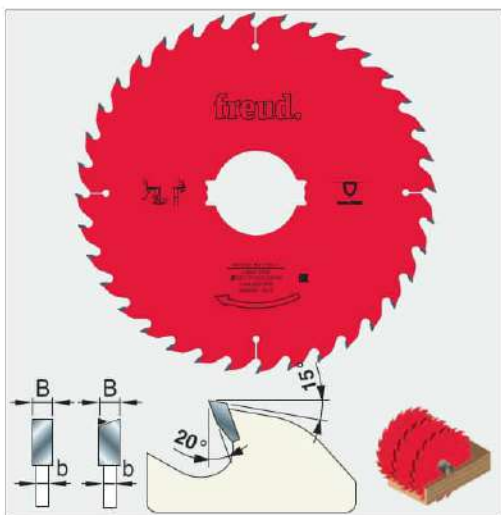
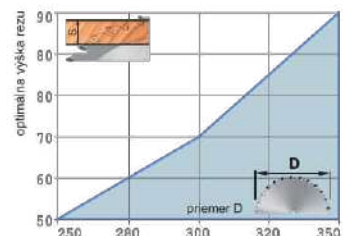

LM08					HW freud	
ROZMIETACIE PÍLOVÉ KOTUČE - ULTRA TENKÉ						
ø D	B	b	ø d	Z	Nr	€
180	1,5	1	40 DKN	24 FZ	280LM080100	42,80
200	1,5	1	40 DKN	28 FZ	280LM080300	48,40
225	1,5	1	40 DKN	28 FZ	280LM080700	49,60
225	1,5	1	40 DKN	36 WZ	280LM081000	52,80
250	1,7	1,2	40 DKN	24 FZ	280LM081400	48,80
250	1,7	1,2	40 DKN	36 WZ	280LM081700	55,60



Pílové kotúče pre štvorstrannú frézozačku a rozrezávacie stroje.

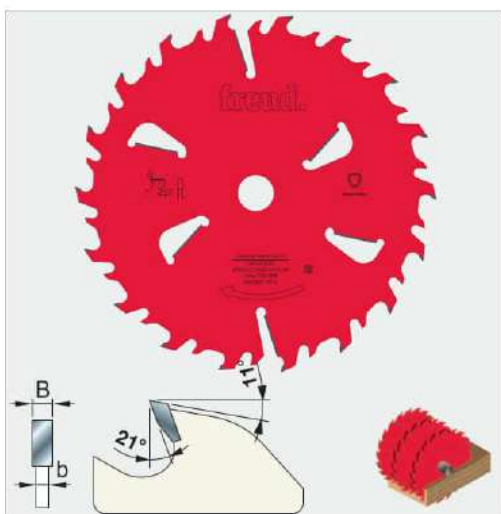
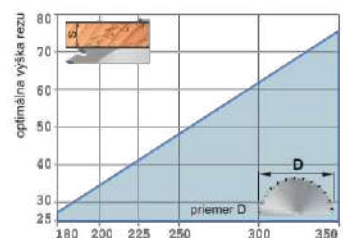

LM10 FZ					HW freud	
ROZMIETACIE PÍLOVÉ KOTUČE - PRE VEĽKÉ HRÚBKÝ						
ø D	B	b	ø d	Z	Nr	€
350	3,9	2,5	50	18+4	280LM1035001	97,60
400	4,4	3	50	18+4	280LM1040001	123,20
450	4,8	3	50	18+6	280LM1045001	157,60
500	5,2	3,5	50	18+6	280LM1050001	146,00
560	5,5	3,5	50	18+6	280LM1056001	231,20



Pílové kotúče špeciálne na mäkké druhy dreven ako topol a pre dreveny s väčším obsahom živice.

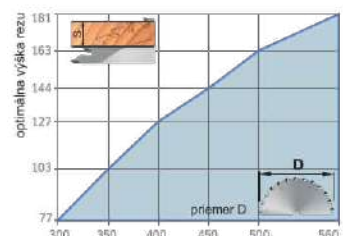

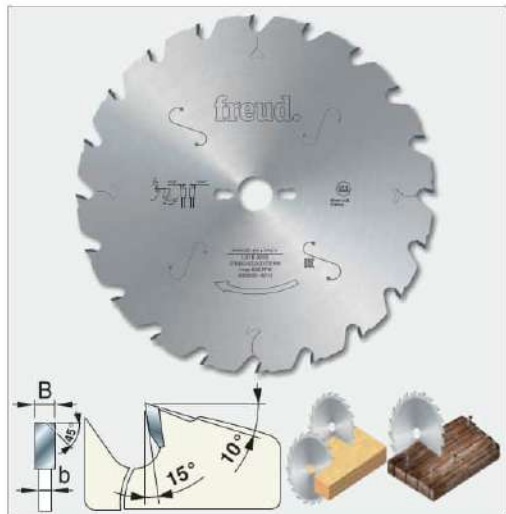

LU1B FZF					HW freud	
PÍLOVÉ KOTUČE NA STAVEBNÉ A ODPADOVÉ DREVO						
ø D	B	b	ø d	Z	Nr	€
250	3,4	2,2	30	18	280LU1B0100	41,20
300	3,4	2,2	30	20	280LU1B0200	48,40
350	3,7	2,5	30	24	280LU1B0400	64,00
400	4	2,8	30	28	280LU1B0500	84,80
450	4,2	3	30	32	280LU1B0600	144,00
500	4,4	3,2	30	36	280LU1B0700	175,20
600	5,2	4	30	48	280LU1B0900	265,60
700	5,6	4,2	30	60	280LU1B1100	477,60



Pílové kotúče na priečne a pozdĺžne rezanie stavebného a znečisteného dreva. Vhodné aj na stavebné materiály.

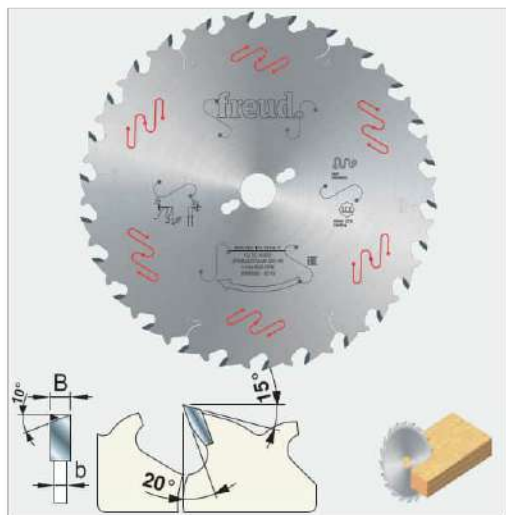
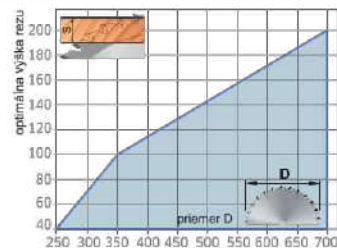

LU1C WZ					HW freud	
KOTUČE NA POZDĹŽNE REZANIE S OBMEDZOVAČOM						
ø D	B	b	ø d	Z	Nr	€
250	3,2	2,2	30	22	280LU1C0100	48,00
300	3,2	2,2	30	26	280LU1C0400	48,60
350	3,5	2,5	30	30	280LU1C1000	61,00
400	4	2,8	30	34	280LU1C1300	92,00
450	4,4	3	30	38	280LU1C1400	152,80
500	4,4	3,2	30	42	280LU1C1500	182,40
550	4,4	3,5	30	48	280LU1C1600	233,60



Pílové kotúče na pozdĺžne rezanie. Vhodné na tvrdé aj mäkké dreviny aj s vypadavými hrčami.

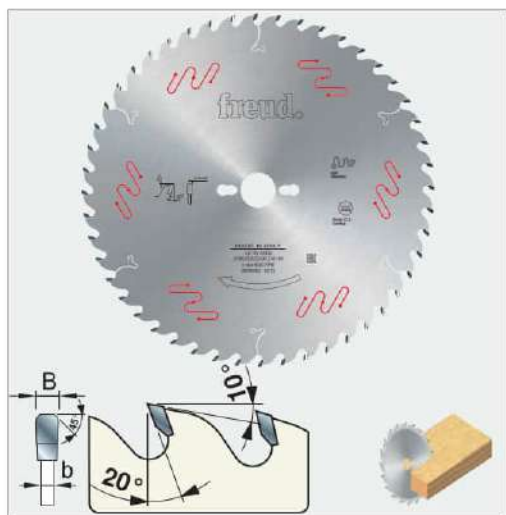
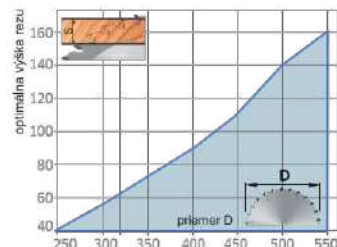

LU1G ABZ					HW freud	
KOTUČE NA POZDĹŽNE REZANIE S OBLÝM BOKOM						
ø D	B	b	ø d	Z	Nr	€
250	3	2	30	40	280LU1G0100	56,00
300	3	2	30	48	280LU1G0200	70,40
350	3,2	2,2	30	60	280LU1G0300	83,20

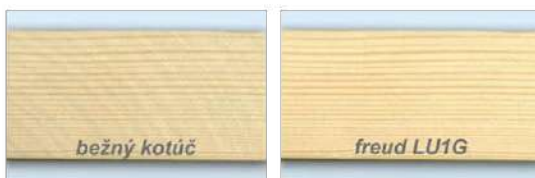

Pílové kotúče na pozdĺžne rezanie mäkkých drevin a vysokými požiadavkami na kvalitu rezu.

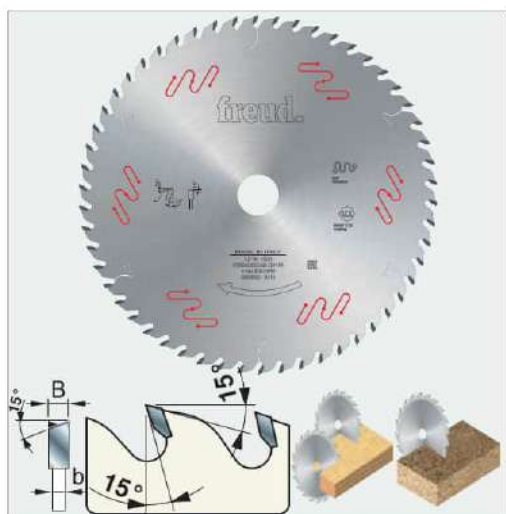
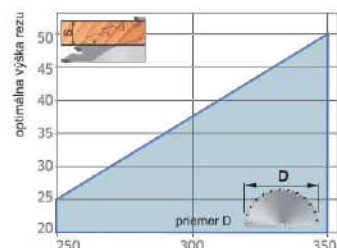

LU1H WZ					HW freud	
PÍLOVÉ KOTUČE UNIVERZÁLNE - TENKÝ PREREZ						
ø D	B	b	ø d	Z	Nr	€
180	1,5	1	30	40	280LU1H0100	38,00
200	1,5	1	30	40	280LU1H0300	42,40
200	1,5	1	30	60	280LU1H0400	52,40
250	2,5	1,6	30	48	280LU1H0700	51,20
250	2,8	2	30	30	280LU1H1500	44,40
250	2,8	2	30	40	280LU1H1600	53,60
300	2,8	2	30	36	280LU1H1400	56,00
300	2,8	2	30	54	280LU1H0900	67,20
350	3	2,2	30	60	280LU1H1200	80,00
350	3	2,2	30	84	280LU1H1300	94,40



Pílové kotúče na priečne a pozdĺžne rezanie dreva a lepeného dreva. Redukovaná hodnota prerezu uľahčuje rezanie vďaka menšiemu reznému odporu.

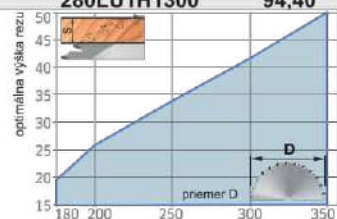



LU2A WZ 15° PÍLOVÉ KOTÚČE NA UNIVERZÁLNE POUŽITIE						HW	freud
ø D	B	b	ø d	Z	Nr	€	
200	3,2	2,2	30	24	280LU2A0700	41,20	
250	3,2	2,2	30	30	280LU2A1600	47,20	
300	3,2	2,2	30	36	280LU2A1900	57,20	
350	3,5	2,5	30	42	280LU2A2500	78,00	
400	4	2,8	30	48	280LU2A3100	101,60	



Píllové kotúče na priečne a pozdĺžne rezanie dreva, surovej drevotriesky a preglejky.

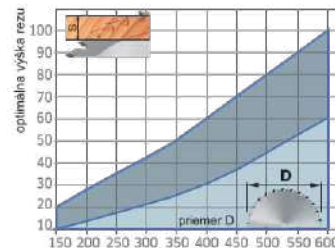

LU2A WZ 10° PÍLOVÉ KOTÚČE NA UNIVERZÁLNE POUŽITIE						HW	freud
ø D	B	b	ø d	Z	Nr	€	
200	3,2	2,2	30	34	280LU2A0800	45,60	
250	3,2	2,2	30	40	280LU2A1700	56,40	
300	3,2	2,2	30	48	280LU2A2100	62,00	
350	3,5	2,5	30	54	280LU2A2800	81,00	
400	4	2,8	30	60	280LU2A3300	124,00	
450	4,4	3	30	66	280LU2A3600	188,00	



Píllové kotúče na priečne a pozdĺžne rezanie dreva, surovej drevotriesky a preglejky s vyššími nárokmi na kvalitu rezu.

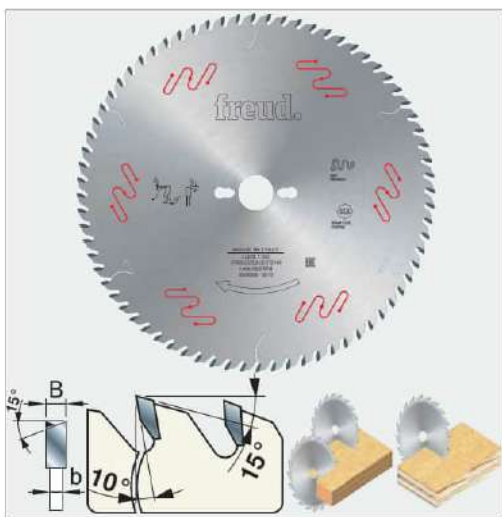
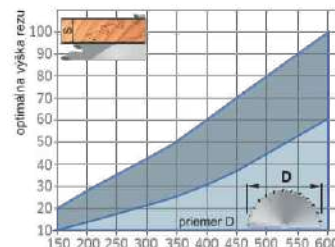

LU2B WZ PÍLOVÉ KOTÚČE NA UNIVERZÁLNE POUŽITIE						HW	freud
ø D	B	b	ø d	Z	Nr	€	
200	3,2	2,2	30	48	280LU2B0300	49,20	
250	3,2	2,2	30	48	280LU2B0500	57,20	
300	3,2	2,2	30	72	280LU2B1100	83,20	
315	3,2	2,2	30	72	280LU2B1300	85,20	
350	3,5	2,5	30	72	280LU2B1400	86,00	
350	3,5	2,5	30	84	280LU2B1600	109,60	
400	4	2,8	30	96	280LU2B1900	136,00	
450	4,4	3	30	96	280LU2B2000	184,80	
500	4,4	3,2	30	108	280LU2B2100	220,00	



Píllové kotúče na priečne a pozdĺžne rezanie dreva, exotických drevín, surovej drevotriesky a preglejky.

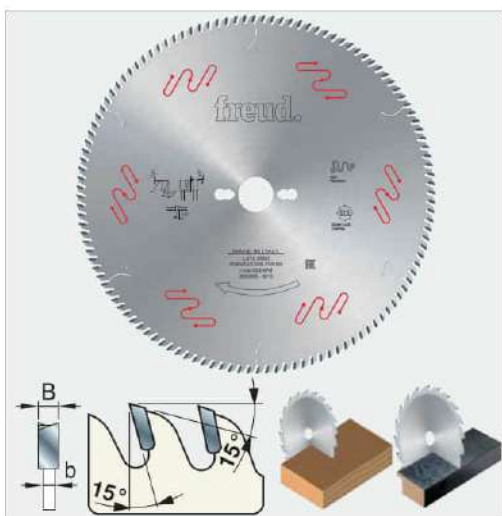
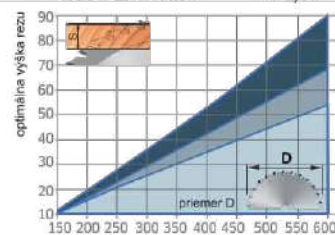

LU1I WZ PÍLOVÉ KOTÚČE NA PRIEČNE REZY						HW	freud
ø D	B	b	ø d	Z	Nr	€	
200	2,95	2,5	30	64	280LU110100	66,00	
250	2,95	2,5	30	80	280LU110300	82,40	
250	2,95	2,5	30	96	280LU110400	95,20	
275	2,95	2,5	20	84	280LU110500	92,00	
300	2,95	2,5	30	96	280LU110600	97,60	
300	2,95	2,5	30	112	280LU110700	115,60	
350	3,45	3	30	108	280LU110900	120,40	



Píllové kotúče na priečne rezanie dreva, profilových listů a rámových profilů s vysokými nárokmi na kvalitu rezu.

OBSAH

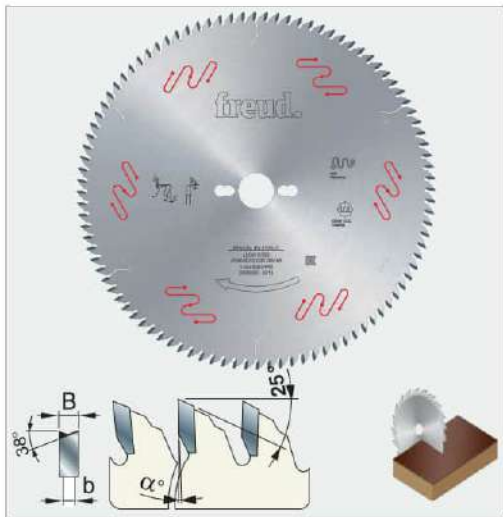

LU3A WZ EXTREMNE ŠIKMÉ PÍLOVÉ KOTUČE PRE FORMÁTOVACIE PÍLY HW freud

ø D	B	b	ø d	Z	Nr	€
220	3.2	2.2	30	64	280LU3A0100	76,80
250	3.2	2.2	30	80	280LU3A0200	85,60
300	3.2	2.2	30	96	280LU3A0300	105,20
350	3.5	2.5	30	108	280LU3A0400	132,00



Pílové kotúče na formátovanie veľkoplošných materiálov - laminovaných, dýhovaných. Vhodné aj bez použitia predrezávacieho kotúča.

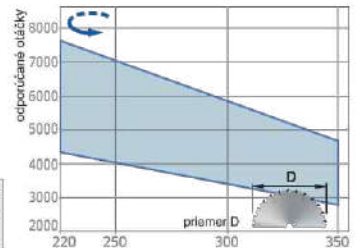

LU3B DHZ DUTÝ ZUB PÍLOVÉ KOTUČE PRE FORMÁTOVACIE PÍLY HW freud

ø D	B	b	ø d	Z	Nr	€
220	3.2	2.2	30	42	280LU3B0100	70,40
250	3.2	2.2	30	48	280LU3B0200	82,40
303	3.2	2.2	30	60	280LU3B0300	103,20
350	3.2	2.2	30	72	280LU3B0400	119,20



Pílové kotúče na formátovanie veľkoplošných materiálov - laminovaných, dýhovaných. Vhodné aj bez použitia predrezávacieho kotúča.

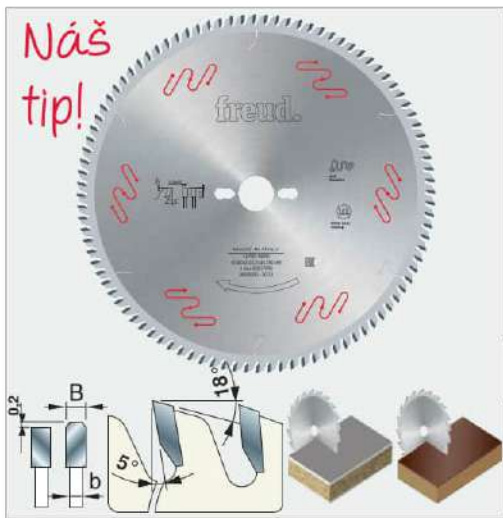
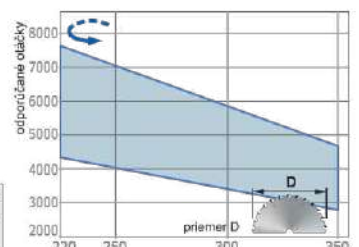

Naš tip!

LU3D TFZ TRAPÉZ POZ. PÍLOVÉ KOTUČE PRE FORMÁTOVACIE PÍLY HW freud

ø D	B	b	ø d	Z	Nr	€
250	3.2	2.2	30	80	280LU3D0400	84,80
280	3.2	2.2	30	84	280LU3D0402	102,00
300	3.2	2.2	30	96	280LU3D0600	80,00
350	3.5	2.5	30	108	280LU3D0900	129,60

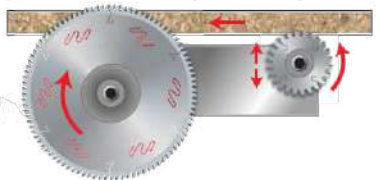

Pílové kotúče na formátovanie veľkoplošných materiálov - laminovaných, dýhovaných s dlhou životnosťou. Pre obojstranne čistý rez je potrebné použiť predrezávací kotúč.

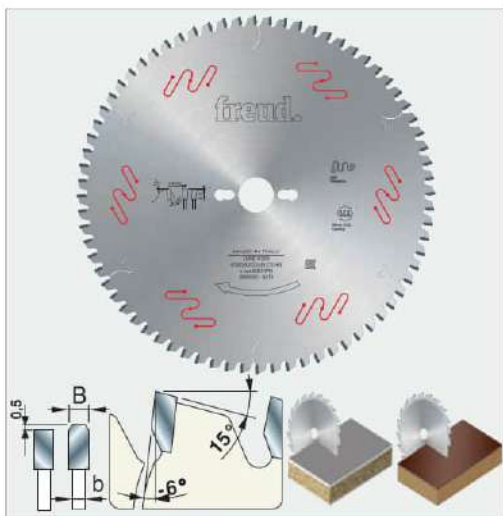
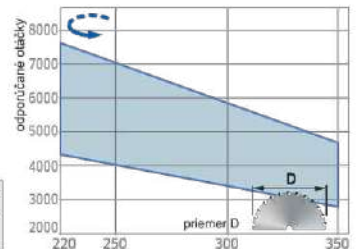

LU3E TFZN TRAPÉZ NEG. PÍLOVÉ KOTUČE PRE FORMÁTOVACIE PÍLY HW freud

ø D	B	b	ø d	Z	Nr	€
220	3.2	2.2	30	56	280LU3E0100	63,60
250	3.2	2.2	30	60	280LU3E0200	69,60
300	3.2	2.2	30	72	280LU3E0300	85,60
350	3.5	2.5	30	84	280LU3E0400	106,80

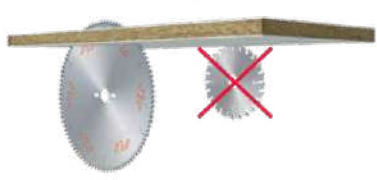

Pílové kotúče na formátovanie veľkoplošných materiálov - laminovaných, dýhovaných hrúbok 25-40mm (pracovné dosky). Vhodné aj bez použitia predrezávacieho kotúča.

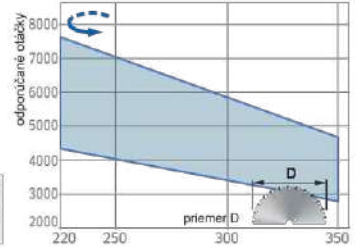



LU4A TFZN		PÍLOVÉ KOTÚČE NA PLASTY A PLEXISKLO		HW	freud	
ø D	B	b	ø d	Z	Nr	€
250	2,8	2,2	30	80	280LU4A0100	83,20
300	2,8	2,2	30	96	280LU4A0200	92,80



Pílové kotúče na rezanie plastov a plexiskla. Pre optimálnu kvalitu rezu musí kotúč presahovať cca 30mm nad rezaný materiál.

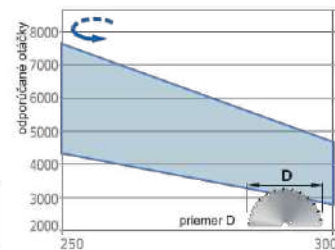

LU4D TTZ		PÍLOVÉ KOTÚČE NA TERMOSETY A HPL		HW	freud	
ø D	B	b	ø d	Z	Nr	€
250	3,2	2,5	30	80	280LU4D0100	97,60
300	3,2	2,5	30	96	280LU4D0200	118,40
350	3,5	2,8	30	108	280LU4D0300	148,80



Pílové kotúče na rezanie vysokoabrazívnych plošných materiálov ako Corian, Fundermax, Trespa.

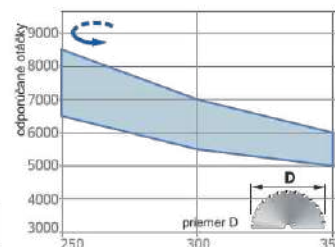

LU5D TFZN		PÍLOVÉ KOTÚČE NA NEŽELEZNÉ MATERIÁLY A PVC		HW	freud	
ø D	B	b	ø d	Z	Nr	€
230	3	2,5	30	64	280LU5D0700	65,60
250	3,5	3	30	80	280LU5D0800	82,40
300	3,5	3	30	96	280LU5D1200	100,00
330	3,5	3	30	104	280LU5D1500	113,60
350	3,5	3	30	108	280LU5D1700	116,40
400	3,5	3	30	120	280LU5D2300	130,40
450	4	3,2	30	128	280LU5D2900	195,20
500	4	3,2	30	140	280LU5D3400	223,20



Pílové kotúče prevažne na skracovanie ťahaných profilov z neželezných kovov a plastov s hrúbkou steny nepresahujúcou 3mm.

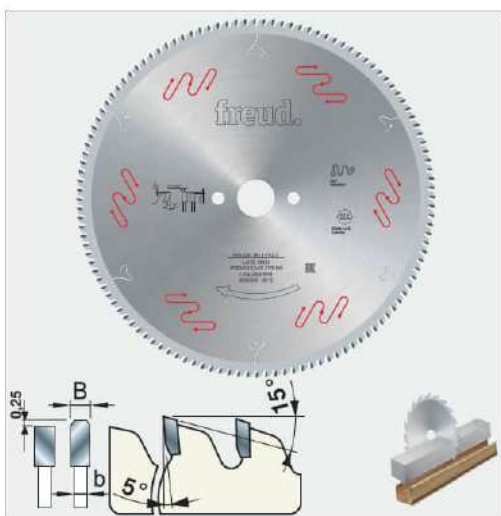
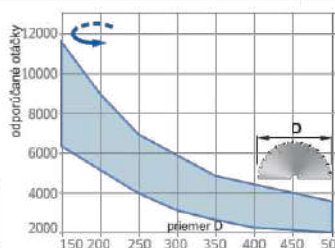

LU5E TFZ		PÍLOVÉ KOTÚČE NA NEŽELEZNÉ MATERIÁLY		HW	freud	
ø D	B	b	ø d	Z	Nr	€
250	2,8	2,2	32	100	280LU5E0200	76,80
255	2,8	2,2	25,4	100	280LU5E0300	76,00
300	3	2,5	30	100	280LU5E0500	87,20
300	3	2,5	30	120	280LU5E0700	95,20
305	3	2,5	25,4	120	280LU5E0600	95,20
350	3	2,5	30	100	280LU5E0900	88,80
350	3	2,5	30	120	280LU5E1100	96,00



Pílové kotúče na rezanie tenkostenných profilov z hliníka a neželezných kovov. Potrebná mechanická fixácia rezaného materiálu.

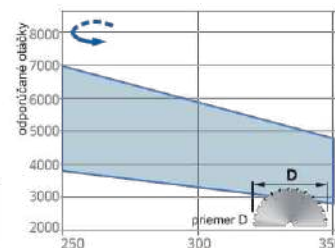



LI16M WZ		DELENÉ PREDREZÁVACIE PÍLOVÉ KOTUČE			HW	freud
ø D	B	ø d	Z	Nr	€	
80	2,8-3,6	20	10+10	280LI16MHA3	75,20	
100	2,8-3,6	20	12+12	280LI16MBA3	64,80	
100	2,8-3,7	22	12+12	280LI16MBB3	69,00	
105	2,8-3,6	20	10+10	280LI16MCA3	75,20	
120	2,8-3,6	20	12+12	280LI16MAA3	64,80	
120	2,8-3,6	22	12+12	280LI16MAB3	64,80	
125	2,8-3,6	20	12+12	280LI16MFA3	82,80	
125	2,8-3,6	22	14+14	280LI16MEB3	89,60	



Predrezávacie pilové kotúče - delené. Nastavenie šírky rezu +0,1 až +0,2 mm oproti hlavnej pile priloženými krúžkami. Hĺbka rezu max. 2mm.

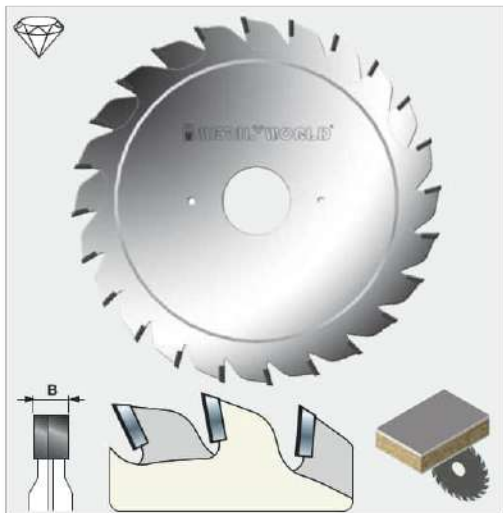

LI21B FZ		DELENÉ PREDREZÁVACIE PÍLOVÉ KOTUČE - PKD			DIA	METAL WORLD
ø D	B	ø d	Z	Nr	€	
80	2,8-3,6	20	10+10	235LI21B0802020	258,30	
100	2,8-3,6	20	10+10	235LI21B1002020	258,30	
100	2,8-3,6	22	10+10	235LI21B1002220	258,30	
120	2,8-3,6	20	12+12	235LI21B1202024	310,00	
120	2,8-3,6	22	12+12	235LI21B1202224	283,30	



Diamantové predrezávacie pilové kotúče - delené. Hĺbka rezu max. 2mm. Možná až 50 násobne vyššia životnosť oproti HM verzii.



LC16D TFZ		PÍLOVÉ KOTUČE PRE FORMÁTOVACIE PÍLY - PKD			DIA	METAL WORLD
ø D	B	ø d	Z	H	Nr	€
250	3,2	30	48	4	235LC16D250048AH4	448,00
250	3,2	30	48	6	235LC16D250048AH6	498,00
300	3,2	30	72	4	235LC16D300072AH4	794,00
300	3,2	30	72	6	235LC16D300072AH6	882,00



Diamantové pilové kotúče na rezanie laminovaných, dýhovaných a fóliovaných materiálov s dlhou životnosťou. Vhodné aj na perez abrazívnych materiálov.

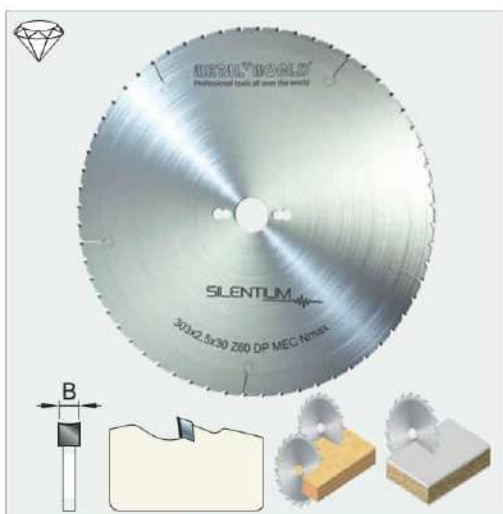

LC71D		UNIVERZÁLNE PÍLOVÉ KOTUČE - SILENIUM PKD			DIA	METAL WORLD
ø D	B	ø d	Z	H	Nr	€
303	2,5	30	54	3	235LC71D303054A	433,30
303	2,5	30	60	3	235LC71D303060A	483,30



Diamantové pilové kotúče na rezanie masívu, laminovaných, dýhovaných a fóliovaných materiálov, abrazívnych materiálov s vysokými požiadavkami na kvalitu rezu a životnosť.



LSBX TFZ PÍLOVÉ KOTUČE PRE NÁREZOVÉ CENTRÁ					HW	freud	
ø D	B	b	ø d	Z	Nr	€	
300	4,4	3	65 SELCO	60	280LSB30002X	130,40	
300	4,4	3	80 SCM	60	280LSB30004X	130,40	
300	4,4	3	65 SELCO	72	280LSB30006X	134,40	
300	4,4	3	75 HOLZMA	72	280LSB30007X	134,40	
300	4,4	3	80 SCM	72	280LSB30008X	134,40	
300	4,4	3	60 HOLZMA	72	280LSB30012X	134,40	
320	4,4	3,2	65 SELCO	72	280LSB32001X	148,80	
320	4,4	3,2	30	60	280LSB32005X	143,20	
320	4,4	3,2	80 SCM	72	280LSB32007X	148,80	
350	4,4	3,2	30 PANHANS	54	280LSB35001X	122,40	
350	4,4	3,2	30 PANHANS	72	280LSB35003X	151,20	
350	4,4	3,2	60 HOLZMA	72	280LSB35004X	137,00	
350	4,4	3,2	80 SCM/GABBIANI	72	280LSB35005X	151,20	
370	4,4	3,2	30 SCHELLING	72	280LSB37001X	166,40	
380	4,4	3,2	80 SCM/GABBIANI	72	280LSB38010X	170,40	
380	4,4	3,2	30	72	280LSB38011X	170,40	
400	4,4	3,2	30	72	280LSB40007X	174,40	
400	4,4	3,2	80 SCM/GABBIANI	72	280LSB40012X	174,40	
430	4,4	3,2	80 SCM/GABBIANI/SELCO	72	280LSB43009X	231,20	
450	4,4	3,2	30 PANHANS/SCM	72	280LSB45007X	233,60	
450	4,8	3,5	60 HOLZMA	72	280LSB45017X	247,20	

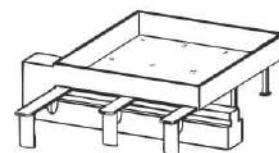

Píllové kotúče pre nárezové centrá prémiovej triedy. Zvýšená tuhosť tela kotúča, tvar zubov a druh spekaného karbidu pre zvýšenú životnosť a kvalitu rezu.

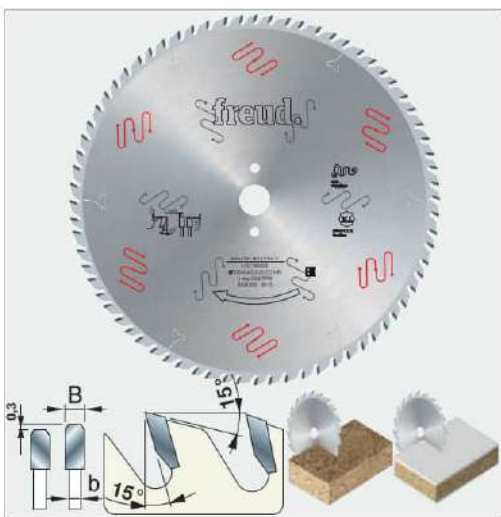

LSC TTZ PÍLOVÉ KOTUČE PRE NÁREZOVÉ CENTRÁ - SUPERCUT					HW	freud	
ø D	B	b	ø d	Z	Nr	€	
300	4,4	3	65 SELCO	60	280LSC30002	122,00	
300	4,4	3	75 HOLZMA	60	280LSC30003	102,20	
300	4,4	3	80 SCM	60	280LSC30004	122,00	
350	4,4	3,2	60 HOLZMA	72	280LSC35004	150,40	
380	4,4	3,2	80 SCM/GABBIANI	72	280LSC38010	165,60	
400	4,4	3,2	80 SELCO	72	280LSC40009	166,40	
400	4,4	3,2	80 SCM/GABBIANI	72	280LSC40012	166,40	

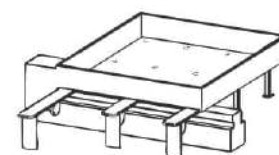

Píllové kotúče pre nárezové centrá s nerovnomerným rozostupom. Určené pre vysoké posuvy a produktivitu pri vysokých nárokoch na kvalitu rezu.

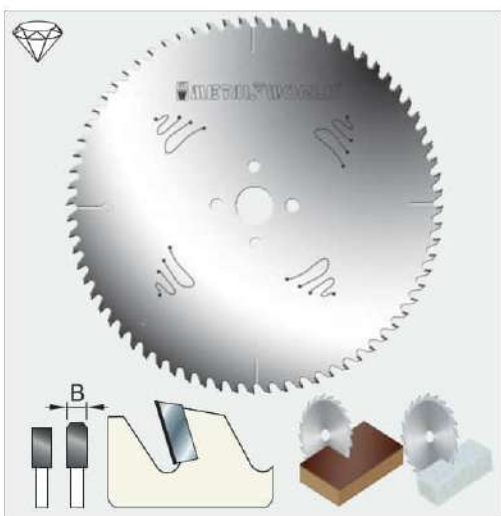

LS16D TFZ PÍLOVÉ KOTUČE PRE NÁREZOVÉ CENTRÁ - PKD, H=6					DIA	METAL WORLD	
ø D	B	b	ø d	Z	Nr	€	
300	4,4	3,2	65 SELCO	60	235LS16D30060SE	912,50	
300	4,4	3,2	75 HOLZMA	60	235LS16D30060HO	912,50	
300	4,4	3,2	80 SCM	60	235LS16D30060SC	912,50	
350	4,4	3,2	60 HOLZMA	72	235LS16D35072HO	1 105,00	
380	4,4	3,2	80 SCM/GABBIANI	72	235LS16D38072GA	1 105,00	
400	4,4	3,2	80 SELCO/SCM/GABBIANI	72	235LS16D40072SE	1 130,10	

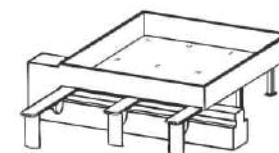

Píllové kotúče pre nárezové centrá v predevení DIA. Určené predovšetkým na materiály na báze MDF a abrazívne materiály.





LI25M KWZ		KÓNICKÉ PREDREZÁVACIE KOTUČE		HW	freud	
ø D	B	b	ø d	Z	Nr	€
80	3,1-4,3	2,2	20	12	280LI25M31AA3	37,60
115	3,1-4,3	2,2	20	24	280LI25M31DA3	42,80
120	2,8-4,0	2,2	22	24	280LI25M28EA3	36,66
120	3,1-4,3	2,2	20	24	280LI25M31EA3	40,00
125	3,1-4,3	2,2	20	24	280LI25M31FA3	41,60
125	4,3-5,5	3,2	20	24	280LI25M43FA3	50,40
150	4,3-5,6	3,2	30 SCM	36	280LI25M43KC3	66,00
150	4,3-5,6	3,2	45 SCM/HOLZMA	38	280LI25M43KE3	66,00
160	3,1-4,3	2,2	20	36	280LI25M31LA3	69,60
160	4,3-5,5	3,2	55 SCM/GABBIANI	36	280LI25M43LG3	72,00
180	3,1-4,3	2,2	16	42	280LI25M31NM3	88,40
180	4,3-5,5	3,2	30 PANHANS	28	280LI25M43NC3	66,80
180	4,3-5,5	3,2	30 HOLZHER	36	280LI25M43XN3	72,80
180	4,3-5,5	3,2	45 HOLZMA	36	280LI25M43NE3	74,40
200	4,3-5,5	3,2	45 HOLZMA	36	280LI25M43PE3	75,20
200	4,3-5,5	3,2	65 SELCO	36	280LI25M43PI3	75,20
200	4,3-5,5	3,2	80 SCM/GABBIANI	36	280LI25M43PL3	75,20
200	4,5-5,7	3	65 SELCO	36	280LI25M45PI3	78,80

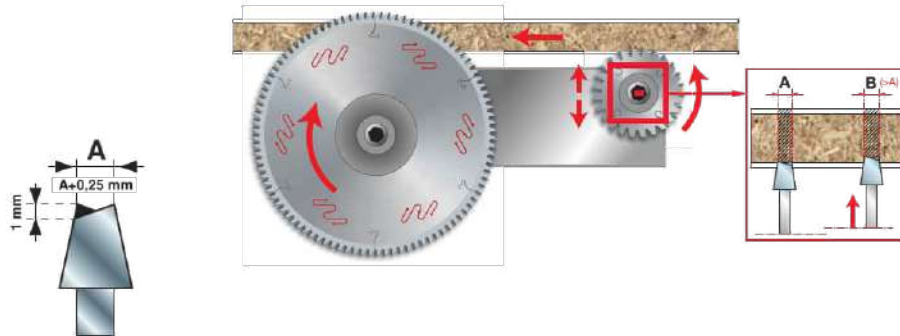

Predrezávacie pilové kotúče pre nárezové centrál aj pre formátovacie pily. Zdvihom o 1mm sa šírka rezu zväčší o 0,25mm.



LI11D KZ		KÓNICKÉ PREDREZÁVACIE KOTUČE - PKD, H=6		DIA	METAL WORLD	
ø D	B	b	ø d	Z	Nr	€
160	4,4-5,5	3,2	55 SCM	36	235LI11D16043SC	510,00
200	4,4-5,5	3,2	45 HOLZMA	36	235LI11D20043HO	510,00
200	4,4-5,5	3,2	80 SCM/GABBIANI	36	235LI11D20043SC	510,80
200	4,4-5,5	3,2	65 SELCO	36	235LI11D20043SE	510,00



Predrezávacie DIA pilové kotúče pre nárezové centrál. Maximálna hĺbka rezu 2mm. Čelo zubov superfinišované.



PL 36		QUICK SET NA DVOJDIELNE PREDREZOVÉ KOTUČE		HW		
ø D	B	b	ø d	Z	Nr	€
120	2,8-3,8	15,1	15 ALTENDORF	12+12	241P3612015	625,00
120	2,8-3,8	22	20 SCM	12+12	241P3612020	625,00
120	2,8-3,8	15,1	20 GRIGGIO	12+12	241P3612120	625,00

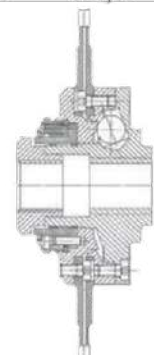

Set je možné namontovať do formátovacej pily. Použitý je zosilnený dvojdielny predrezávaci kotúč. Šírka rezu sa nastavuje pootáčaním matice prípravku priamo na hriadele pily bez potreby demontáže.



TR10M SEGMENTOVÉ ROZTRIESKOVAČE - KÓNICKÉ HW **METAL WORLD**

ø D	B	ø d	Z	€
250	34,6	80	4x7	závislý od tech.špecifikácie
300	34,6	80	6x7	závislý od tech.špecifikácie
350	34,6	80	8x7	závislý od tech.špecifikácie

PRÍKLADY UPNUTIA

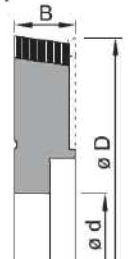
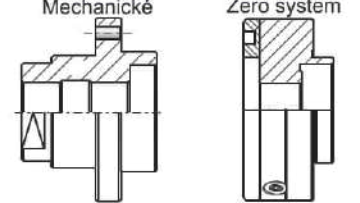

Roztrieskovače pre čapovacie a cinkovacie stroje. Možnosť použiť aj v olejovacích linkách. Okrem upnutia na presný otvor a montážne skrutky, je možné nástroj osadiť aj na iné typy pneumatických, hydraulických, mechanických a kombinovaných upínacích prírub. Krajový pilový kotúč môže byť vo vyhotovení HW alebo DIA.



TR20M SEGMENTOVÉ ROZTRIESKOVAČE - ROVNÉ HW **METAL WORLD**

ø D	B	ø d	Z	€
250	19,6	80	6x4	závislý od tech.špecifikácie
250	19,6	80	6x4	závislý od tech.špecifikácie

PRÍKLADY UPNUTIA

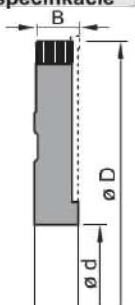
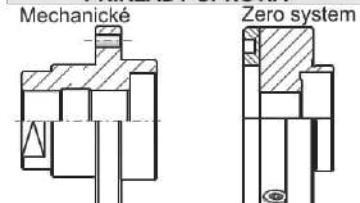

Roztrieskovače pre uhlové formátovacie linky. Okrem upnutia na presný otvor a montážne skrutky, je možné nástroj osadiť aj na iné typy pneumatických, hydraulických, mechanických a kombinovaných upínacích prírub. Krajový pilový kotúč môže byť vo vyhotovení HW alebo DIA.



FT06D ROZTRIESKOVAČE - PKD DIA **METAL WORLD**

Upínací otvor + 4 drážky na rýchloupínací systém D150 a 6 otvorov na priamu montáž D120

ø D	B	ø d	Z	€
250	16	80	24+24	závislý od tech.špecifikácie
250	16	80	30+30	závislý od tech.špecifikácie

Upínací otvor + 4 drážky na rýchloupínací systém D130.

ø D	B	ø d	Z	€
250	16	60	24+24	závislý od tech.špecifikácie
250	16	60	30+30	závislý od tech.špecifikácie

PRÍKLADY UPNUTIA

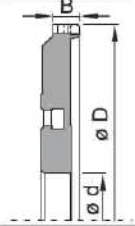
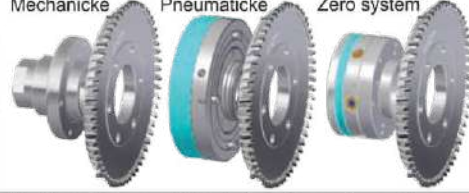

Univerzálne roztrieskovače pre uhlové formátovacie a olejovacie linky. Vysoká životnosť nástroja, optimálny pomer cena / výkon.



FT70D ROZTRIESKOVAČE EVOLUTION - PKD DIA **METAL WORLD**

Upínací otvor + 4 drážky na rýchloupínací systém D150 a 6 otvorov na priamu montáž D120

ø D	B	ø d	Z	€
250	15,4	80	16+8+4+4	závislý od tech.špecifikácie
250	15,4	80	20+10+5+5	závislý od tech.špecifikácie

Upínací otvor + 4 drážky na rýchloupínací systém D130.

ø D	B	ø d	Z	€
250	15,4	60	16+8+4+4	závislý od tech.špecifikácie
250	15,4	60	20+10+5+5	závislý od tech.špecifikácie

PRÍKLADY UPNUTIA

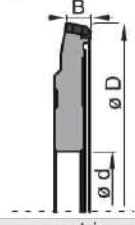

Vysoko výkonné roztrieskovače s nerovnomerným rozstupom a premenlivou geometriou. Vďaka unikátnej konštrukcii sa vyznačujú tichým chodom a vysokou kvalitou obrobenej plochy.

OBSAH



LP20 WZ		POZDĽŽNE REZANIE		KOTUČE PRE RUČNÉ KOTUČOVÉ PÍLY		HW	frend
ø D	B	b	ø d	Z	Nr	€	
* 150	2,4	1,6	16	12	280LP20M004PKZ	21,90	
* 150	2,4	1,6	20	12	280LP20M005PKZ	21,90	
* 160	2,4	1,6	16	12	280LP20M006PKZ	21,90	
160	2,4	1,6	20	12	280LP20M007PKZ	26,80	
* 160	2,4	1,6	30	12	280LP20M008PKZ	21,90	
* 180	2,4	1,6	20	12	280LP20M010PKZ	21,90	
180	2,4	1,6	30	12	280LP20M011PKZ	29,00	
184	2,4	1,6	16	12	280LP20M012PKZ	30,50	
* 190	2,4	1,6	16	12	280LP20M013PKZ	24,70	
* 190	2,4	1,6	20	12	280LP20M014PKZ	24,70	
190	2,4	1,6	30	12	280LP20M015PKZ	32,00	
200	2,4	1,6	30	16	280LP20M016PKZ	33,60	
* 210	2,4	1,6	25	16	280LP20M017PKZ	29,50	
210	2,4	1,6	30	16	280LP20M018PKZ	35,30	
* 216 negatív	2,4	1,6	30	24	280LP20M019PKZ	43,00	
220	2,4	1,6	30	16	280LP20M020PKZ	31,40	
230	2,8	1,8	30	20	280LP20M021PKZ	41,00	
235	2,8	1,8	30	24	280LP20M023PKZ	42,10	
* 240	2,8	1,8	30	24	280LP20M024PKZ	36,10	
250	2,8	1,8	30	24	280LP20M025PKZ	44,10	



* skladom do vypredania zásob

Pilové kotúče určené na pozdĺžne rezanie dreva. Vhodné aj na rezanie aglomerátov s nízkou požiadavkou na kvalitu rezu. Kotúč s negatívnou geometriou je vhodný aj do skrakovacích píľ.



LP30 WZ		UNIVERZÁLNE POUŽITIE		KOTUČE PRE RUČNÉ KOTUČOVÉ PÍLY		HW	frend
ø D	B	b	ø d	Z	Nr	€	
* 125	2,4	1,6	20	24	280LP30M001PKC	28,50	
130	2,4	1,6	20	24	280LP30M002PKC	29,90	
140	2,4	1,6	20	24	280LP30M003PKC	29,90	
150	2,4	1,6	16	24	280LP30M004PKC	29,90	
150	2,4	1,6	20	24	280LP30M005PKC	29,90	
160	2,4	1,6	16	24	280LP30M006PKC	30,70	
160	2,4	1,6	20	24	280LP30M007PKC	30,70	
160	2,4	1,6	30	24	280LP30M008PKC	30,70	
* 170	2,4	1,6	30	24	280LP30M009PKC	30,40	
180	2,4	1,6	20	24	280LP30M010PKC	33,30	
180	2,4	1,6	30	24	280LP30M011PKC	33,30	
* 184	2,4	1,6	16	24	280LP30M012PKC	30,40	
* 190	2,4	1,6	16	24	280LP30M013PKC	35,90	
190	2,4	1,6	20	24	280LP30M014PKC	35,90	
190	2,4	1,6	30	24	280LP30M015PKC	35,90	
200	2,4	1,6	30	30	280LP30M016PKC	35,90	
* 210	2,4	1,6	25	30	280LP30M017PKC	33,30	
210	2,4	1,6	30	30	280LP30M018PKC	37,70	
* 216 negatív	2,4	1,6	30	48	280LP30M019PKC	59,80	
220	2,4	1,6	30	30	280LP30M020PKC	35,90	
230	2,8	1,8	30	34	280LP30M021PKC	45,40	
* 235	2,8	1,8	25	34	280LP30M022PKC	34,17	
235	2,8	1,8	30	34	280LP30M023PKC	38,80	
* 240	2,8	1,8	30	36	280LP30M024PKC	41,50	
250	2,8	1,8	30	40	280LP30M025PKC	60,90	



* skladom do vypredania zásob

Pilové kotúče určené na priečne a pozdĺžne rezanie dreva. Pozdĺžne rezanie menších hrúbok pri zvýšených nárokoch na kvalitu rezu. Vhodné aj na rezanie aglomerátov.



LP40 WZ		PRIEČNE REZANIE		KOTUČE PRE RUČNÉ KOTUČOVÉ PÍLY		HW	frend
ø D	B	b	ø d	Z	Nr	€	
160	2,4	1,6	16	40	280LP40M006PKM	37,00	
160	2,4	1,6	20	40	280LP40M007PKM	37,00	
160	2,4	1,6	30	40	280LP40M008PKM	37,00	
170	2,4	1,6	30	40	280LP40M009PKM	36,00	
180	2,4	1,6	20	40	280LP40M010PKM	39,80	
180	2,4	1,6	30	40	280LP40M011PKM	39,80	
184	2,4	1,6	16	40	280LP40M012PKM	38,10	
190	2,4	1,6	16	40	280LP40M013PKM	43,40	
190	2,4	1,6	20	40	280LP40M014PKM	43,40	
190	2,4	1,6	30	40	280LP40M015PKM	43,40	
200	2,4	1,6	30	40	280LP40M016PKM	43,90	
210	2,4	1,6	25	40	280LP40M017PKM	38,00	
210	2,4	1,6	30	40	280LP40M018PKM	41,70	
220	2,4	1,6	30	40	280LP40M020PKM	44,20	
230	2,8	1,8	30	48	280LP40M021PKM	50,40	
235	2,8	1,8	25	48	280LP40M022PKM	45,20	
235	2,8	1,8	30	48	280LP40M023PKM	51,50	
240	2,8	1,8	30	48	280LP40M024PKM	52,60	
250	2,8	1,8	30	60	280LP40M025PKM	72,40	



Pilové kotúče určené hlavne na priečne rezanie dreva. Vhodné aj na rezanie aglomerátov.



FRLP PÍLOVÉ KOTUČE PRE RUČNÉ KOTUČOVÉ PÍLY - LDTD HW **freud**

Ručné kotúčové píly

$\varnothing D$	B	b	$\varnothing d$	Z	Nr	€
160	2,2	1,6	20	48 TFZN	280FR06L002H	46,40
160	1,8	1,2	20	48 WZN	280FR06L003HC	42,50
165	2,6	1,6	20	48 WZN	280FR07L001H	48,20
165	1,8	1,2	20	48 WZN	280FR07L002HC	44,00
185	2,4	1,6	20	60 WZN	280FR12L001H	51,50
190	2,6	1,6	30	60 WZN	280FR13L001H	59,20
190	2,1	1,4	30	60 WZN	280FR13L002HC	59,00

Pokosové píly

$\varnothing D$	B	b	$\varnothing d$	Z	Nr	€
216	2,8	1,8	30	64 TFZN	280FR16H001M	69,12
250	2,8	1,8	30	80 TFZN	280FR23H001M	86,40
254	2,8	1,8	30	80 TFZN	280FR24H001M	86,40
305	3,2	3,2	30	96 TFZN	280FR29H001M	105,60

Malé stolové píly

$\varnothing D$	B	b	$\varnothing d$	Z	Nr	€
200	2,5	1,8	30	64 WZN	280FR14L001T	55,20
210	2,1	1,4	30	66 WZN	280FR15L001TC	63,36
250	2,8	1,8	30	80 WZN	280FR23L001T	80,80
300	2,8	1,8	30	96 WZN	280FR28L001T	96,80



Vybraný sortiment píllových kotúčov určených na rezanie laminovaných a dýhovaných materiálov.



FRAL PÍLOVÉ KOTUČE PRE RUČNÉ KOTUČOVÉ PÍLY - ALU HW **freud**

Ručné kotúčové píly

$\varnothing D$	B	b	$\varnothing d$	Z	Nr	€
160	2,2	1,6	20	52 TFZN	280FR06A001H	46,40
160	1,8	1,3	20	54 TFZN	280FR06A002HC	44,40
165	2,5	1,6	20	52 TFZN	280FR07A001H	51,50
165	1,8	1,3	20	54 TFZN	280FR07A002HC	49,50
190	2,5	1,6	30	56 TFZN	280FR13A002H	52,00
190	1,8	1,3	30	54 TFZN	280FR13A003HC	51,20

Pokosové píly

$\varnothing D$	B	b	$\varnothing d$	Z	Nr	€
216	2,5	1,8	30	64 TFZN	280FR16A001M	59,20
216	2	1,4	30	66 TFZN	280FR16A002MC	57,60
250	2,8	2	30	80 TFZN	280FR23A001M	79,20
250	2,4	1,8	30	78 TFZN	280FR23A002MC	76,80
254	2,8	2	30	80 TFZN	280FR24A001M	73,60
260	2,3	1,8	30	80 TFZN	280FR26A001M	74,40
300	2,8	2	30	96 TFZN	280FR28A001M	92,80
305	2,8	2	30	96 TFZN	280FR29A001M	94,40
305	2,4	1,8	30	96 TFZN	280FR29A004MC	92,80
315	2,8	2,2	30	96 TFZN	280FR30A001M	107,20

Malé stolové píly

$\varnothing D$	B	b	$\varnothing d$	Z	Nr	€
210	2	1,4	30	66 TFZ	280FR15A001TC	56,80
250	2,8	2	30	68 TFZN	280FR23A001T	73,60
300	3,2	2,2	30	96 TFZ	280FR28H001T	102,60



Kotúče určené na rezanie tenkostenných hliníkových profilov a HPL dosiek.



FRFC PÍLOVÉ KOTUČE PRE RUČNÉ KOTUČOVÉ PÍLY - CONSTRUCT DIA **freud**

Ručné kotúčové píly

$\varnothing D$	B	b	$\varnothing d$	Z	Nr	€
160	2,2	1,6	20	4 TZ	280FR06F001H	59,40
160	1,8	1,2	20	4 TZ	280FR06F002HC	57,60
165	2,2	1,6	20	4 TZ	280FR07F001H	71,30
165	1,8	1,2	20	4 TZ	280FR07F002HC	69,12
190	2,2	1,6	30	4 TZ	280FR13F002H	80,64
190	1,8	1,2	30	4 TZ	280FR13F003HC	80,64
235	2,2	1,6	30	6 TZ	280FR20F001H	120,96

Pokosové píly, malé stolové píly

$\varnothing D$	B	b	$\varnothing d$	Z	Nr	€
216	2,2	1,6	30	6 TZ	280FR16F001M	117,12
216	2	1,4	30	6 TZ	280FR16F002MC	117,10
250	2,4	1,8	30	6 TZ	280FR23F001M	131,50
250	2,2	1,6	30	6 TZ	280FR23F002MC	131,50
254	2,4	1,8	30	6 TZ	280FR24F001M	133,40
260	2,4	1,8	30	6 TZ	280FR26F001M	136,32
300	2,4	1,8	30	8 TZ	280FR28F001M	162,20
305	2,4	1,8	30	8 TZ	280FR29F001M	162,20
305	2,2	1,6	30	8 TZ	280FR29F002MC	162,20



Vybraný sortiment píllových kotúčov určených na rezanie cementotrieskových dosiek, sadrokartónu a stavebných materiálov s minerálnym plnivom.





FRMM		KOTUČE PRE RUČNÉ KOTUČOVÉ PÍLY - MULTICUT		HW	freud	
ø D	B	b	ø d	Z	Nr	€
160	2	1,6	20	30	280FR06M001H	51,80
190	2	1,6	30	38	280FR13M001H	64,32
216	2	1,6	30	40	280FR16M001M	70,10
250	2,4	2	30	48	280FR23M001M	84,50
254	2,4	2	30	48	280FR24M001M	84,50
300	2,6	2	30	80	280FR28M001M	115,20
305	2,6	2	30	80	280FR29M001M	120,00



Univerzálne pilové kotúče určené na rezanie širokého spektra materiálov s vysokou odolnosťou voči poškodeniu zubov, bez zvýšených nárokov na kvalitu rezu.



5392 FZ		DRAŽKOVACIE PÍLOVÉ KOTUČE PRE KOTUČOVÉ PÍLY		HW	Titana	
ø D	B	b	ø d	Z	Nr	€
180	4	2,5	30	16	2219218040	28,27
180	5	3,5	30	16	2219218050	31,53
180	6	3,5	30	16	2219218060	38,00
200	4	2,5	30	32	2219220040	41,00
200	5	3,5	30	32	2219220050	50,27

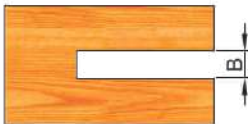

Kompletný sortiment nájdete na strane 1.1.



GL20		DADO SET		HW	freud
ø D	B	ø d	Z	Nr	€
207	6-22	30	12+2+2+2+2+2+12	280GL20701M	249,00

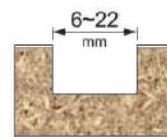

Sada pilových kotúčov pre frézovanie drážok na formátovacích pilách. Sada pozostáva z 2 krajových a 5 stredových kotúčov, pomocou ktorých je možné frézovať drážky požadovanej šírky. Formátovacia píla musí mať predprípravu, aby vedela bezpečne používať tento nástroj.

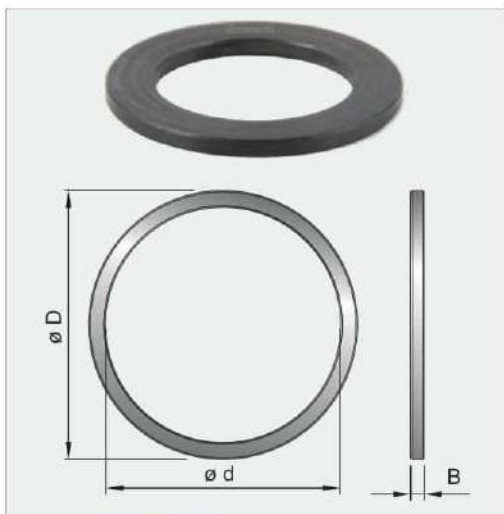

REDUKČNÉ KRUŽKY PRE PÍLOVÉ KOTUČE				
ø D	B	ø d	Nr	€
20	1,4	12,75	221500	1,50
20	1,4	16	221501	1,50
25	1,4	16	221513	1,50
25,4	1,8	20	221508	1,50
30	1,8	12,75	221502	1,50
30	1,8	16	221507	1,92
30	1,8	20	221503	2,33
30	1,8	22	221509	2,33
30	1,8	25	221504	1,50
30	1,8	25,4	221505	2,08
32	2,2	30	221506	2,08
32	1,8	25,4	221511	1,50
32	2,2	25,4	221512	1,50
35	2,2	30	221510	2,00

OBSAH

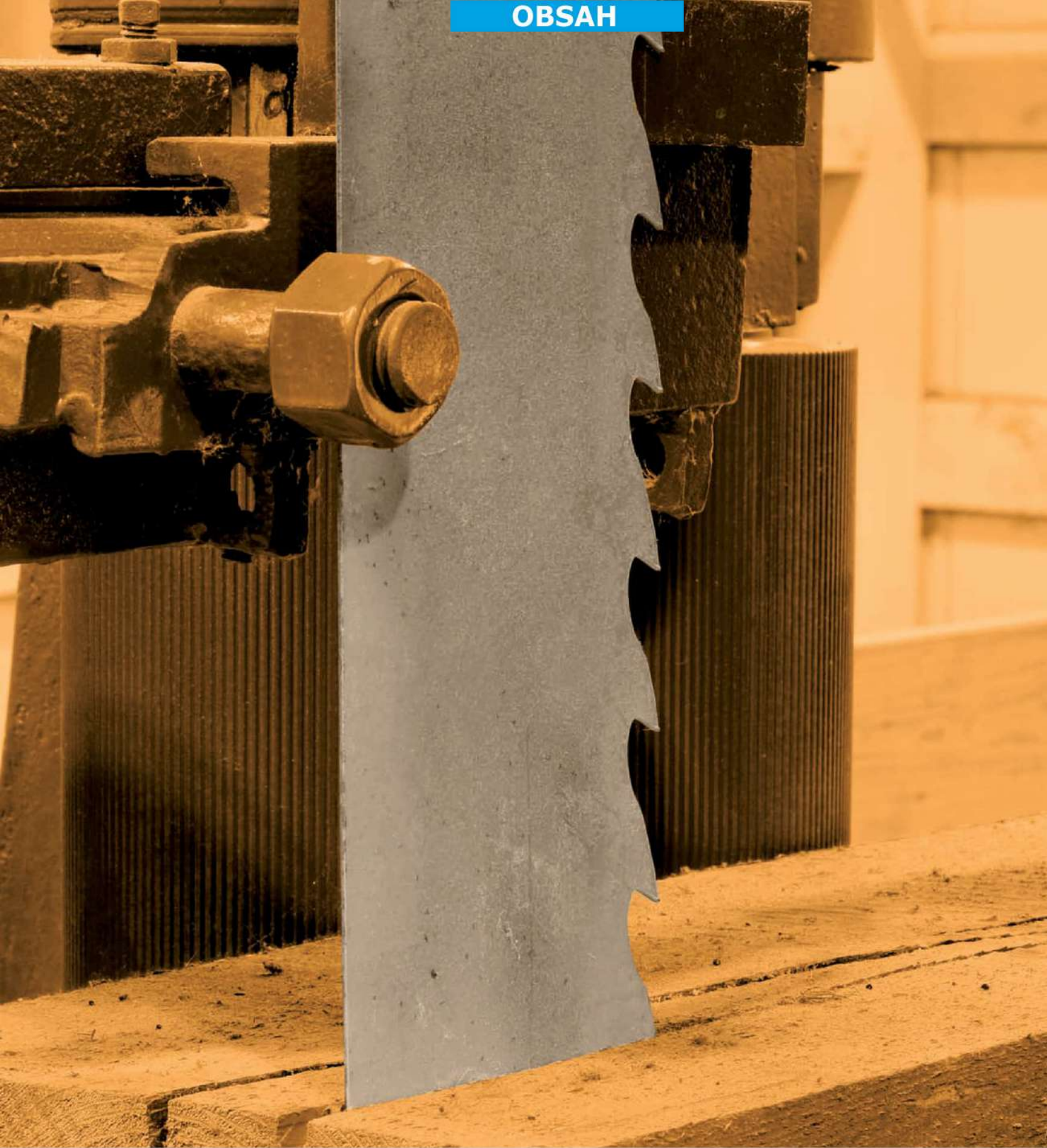

PÍLOVÉ PÁSY



eshop.woodb.sk

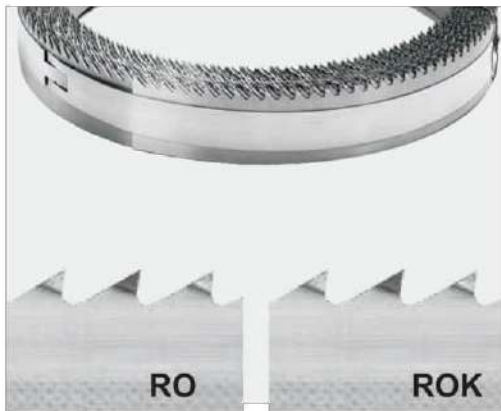

C75 PÍLOVÉ PÁSY STOLÁRSKE



RO rozvedené, ostrené						ROK rozvedené, ostrené, kalené					
H	S	t	Nr	€		H	S	t	Nr	€	
6	0,5	4	223031	0,86		6	0,5	4	223031	0,86	
8	0,5	5	223041	1,04		8	0,5	5	223041	1,04	
10	0,6	6	223051	1,16		10	0,6	6	223051	1,16	
12	0,6	7	223062	1,38		12	0,6	7	223062	1,38	
15	0,6	7	223071	1,38		15	0,6	7	223071	1,38	
20	0,6	8	223081	1,72		20	0,6	8	223081	1,72	
25	0,6	8	223082	1,62		25	0,6	8	223082	1,62	
25	0,7	8	223091	2,20		25	0,7	8	223091	2,20	
30	0,7	10	223101	2,42		30	0,7	10	223101	2,42	
35	0,7	10	223111	2,72		35	0,7	10	223111	2,72	

Pásy sú balené v 25 m. zvitkoch. Zabezpečujeme zváranie pásov, ich rozvedenie a naostrenie. RO-vyzubený, rozvedený, ostrený ROK-vyzubený, rozvedený, ostrený, kalený



FLEXBACK PÍLOVÉ PÁSY STOLÁRSKE

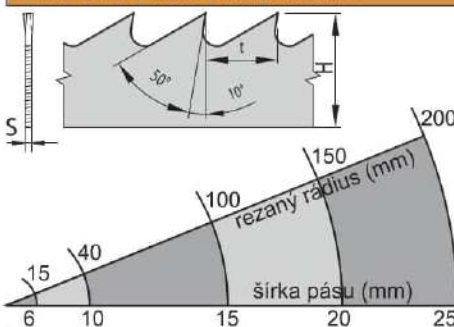
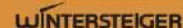

ROK rozvedené, ostrené, kalené					
H	S	t	Nr	€	
6	0,5	6	223WF060506	2,85	
8	0,65	6	223WF080656	2,90	
10	0,5	6	223WF100556	3,10	
12	0,5	4	223WF120504	3,20	
12	0,6	4	223WF120604	3,00	
16	0,5	4	223WF160504	3,20	
16	0,7	4	223WF160704	3,20	
20	0,5	4	223WF200504	3,40	
20	0,65	4	223WF200654	3,82	
25	0,5	4	223WF250504	3,50	
25	0,7	4	223WF250704	3,50	
30	0,7	3	223WF300703	3,70	

Pásy sú balené v 25 m. zvitkoch. Zabezpečujeme zváranie pásov, ich rozvedenie a naostrenie. ROK-vyzubený, rozvedený, ostrený, kalený

FLEXBACK PÍLOVÉ PÁSY STOLÁRSKE ZVÁRANÉ



dĺžka	šírka pilového pásu mm / cena €									
	6mm	€	8mm	€	10mm	€	12mm	€	16mm	€
2240	223W06/2240	12,-	223W08/2240	12,-	223W10/2240	12,-	223W12/2240	12,-	223W14/2240	12,-
2240	223W06/2240	12,-	223W08/2240	12,-	223W10/2240	12,-	223W12/2240	12,-	223W14/2240	12,-
1712	223W06/1712	10,-	223W08/1712	10,-	223W10/1712	10,-	223W12/1712	11,-	223W14/1712	11,-
2215	223W06/2215	11,-	223W08/2215	12,-	223W10/2215	12,-	223W12/2215	12,-	223W14/2215	12,-
2095	223W06/2095	11,-	223W08/2095	11,-	223W10/2095	12,-	223W12/2095	12,-	223W14/2095	12,-
1400	223W06/1400	9,-	223W08/1400	9,-	223W10/1400	9,-	223W12/1400	10,-	223W14/1400	10,-
2946	223W06/2946	14,-	223W08/2946	14,-	223W10/2946	14,-	223W12/2946	15,-	223W14/2946	15,-
3695	223W06/3695	16,-	223W08/3695	16,-	223W10/3695	17,-	223W12/3695	17,-	223W14/3695	17,-
1575	223W06/1575	10,-	223W08/1575	10,-	223W10/1575	10,-	223W12/1575	10,-	223W14/1575	10,-
1712	223W06/1712	10,-	223W08/1712	10,-	223W10/1712	10,-	223W12/1712	11,-	223W14/1712	11,-
2240	223W06/2240	12,-	223W08/2240	12,-	223W10/2240	12,-	223W12/2240	12,-	223W14/2240	12,-
1400	223W06/1400	9,-	223W08/1400	9,-	223W10/1400	9,-	223W12/1400	10,-	223W14/1400	10,-
1826	223W06/1826	10,-	223W08/1826	10,-	223W10/1826	11,-	223W12/1826	11,-	223W14/1826	11,-
1400	223W06/1400	9,-	223W08/1400	9,-	223W10/1400	9,-	223W12/1400	10,-	223W14/1400	10,-
2360	223W06/2360	12,-	223W08/2360	12,-	223W10/2360	12,-	223W12/2360	13,-	223W14/2360	13,-
1490	223W06/1490	9,-	223W08/1490	9,-	223W10/1490	10,-	223W12/1490	10,-	223W14/1490	10,-
2360	223W06/2360	12,-	223W08/2360	12,-	223W10/2360	12,-	223W12/2360	13,-	223W14/2360	13,-
1572	223W06/1572	10,-	223W08/1572	10,-	223W10/1572	10,-	223W12/1572	10,-	223W14/1572	10,-
3454	223W06/3454	15,-	223W08/3454	15,-	223W10/3454	16,-	223W12/3454	16,-	223W14/3454	16,-
2240	223W06/2240	12,-	223W08/2240	12,-	223W10/2240	12,-	223W12/2240	12,-	223W14/2240	12,-
2950	223W06/2950	14,-	223W08/2950	14,-	223W10/2950	14,-	223W12/2950	15,-	223W14/2950	15,-
4085	223W06/4085	17,-	223W08/4085	17,-	223W10/4085	18,-	223W12/4085	18,-	223W14/4085	18,-
5020	223W06/5020	19,-	223W08/5020	20,-	223W10/5020	21,-	223W12/5020	21,-	223W14/5020	21,-
2490	223W06/2490	12,-	223W08/2490	12,-	223W10/2490	13,-	223W12/2490	13,-	223W14/2490	13,-
1720	223W06/1720	10,-	223W08/1720	10,-	223W10/1720	10,-	223W12/1720	11,-	223W14/1720	11,-
1575	223W06/1575	10,-	223W08/1575	10,-	223W10/1575	10,-	223W12/1575	10,-	223W14/1575	10,-
2240	223W06/2240	12,-	223W08/2240	12,-	223W10/2240	12,-	223W12/2240	12,-	223W14/2240	12,-
2950	223W06/2950	14,-	223W08/2950	14,-	223W10/2950	14,-	223W12/2950	15,-	223W14/2950	15,-
3430	223W06/3430	15,-	223W08/3430	15,-	223W10/3430	16,-	223W12/3430	16,-	223W14/3430	16,-
1825	223W06/1825	10,-	223W08/1825	10,-	223W10/1825	11,-	223W12/1825	11,-	223W14/1825	11,-
2560	223W06/2560	12,-	223W08/2560	13,-	223W10/2560	13,-	223W12/2560	13,-	223W14/2560	13,-

Pilové pásy sú dodávané nabrúsené, rozvedené, zvarené. Pri objednávaní iných rozmerov zvarených pásov dbajte na uvedenie správnej dĺžky pásu / stred min – max dĺžky/.

Makita	LB1200F
metabo	BAS317/318
metabo	BAS260/261
DEWALT	DW876
DEWALT	DW738/739
PARKSIDE	PBS350
LAGUNA	1412/14BX
LAGUNA	1412/18BX
JET	JWBS9-X
JET	JWBS-10
JET	JBS-12
Milwaukee	TC-SB200/1
Skarpach	HBS260
Skarpach	HBS30
Skarpach	BASA3
Skarpach	BASA1.0
Skarpach	BASA5
RYOBI	RBS904
HOLZMANN	HBS470
HOLZMANN	HBS300J
HOLZMANN	HBS400
HOLZMANN	HBS610
HOLZMANN	HBS700
PROMA	PP350
PROMA	PP250
PROMA	PP225
PROMA	PP305/312
PROMA	PP400
PROMA	PP500
PROMA	PP254
PROMA	PP340

FLEXBACK PÍLOVÉ PÁSY TESÁRSKE - ZVÁRANÉ



dĺžka	šírka pilového pásu mm / cena €									
	6mm	€	8mm	€	10mm	€	12mm	€	16mm	€
1752	223W06/1752	10,-	223W08/1752	10,-	223W10/1752	11,-	223W12/1752	11,-	223W14/1752	11,-
1592	223W06/1592	10,-	223W08/1592	10,-	223W10/1592	10,-	223W12/1592	10,-	223W14/1592	10,-
1710	223W06/1710	10,-	223W08/1710	10,-	223W10/1710	10,-	223W12/1710	11,-	223W14/1710	11,-
2720	223W06/2720	13,-	223W08/2720	13,-	223W10/2720	14,-	223W12/2720	14,-	223W14/2720	14,-
3650	223W06/3650	16,-	223W08/3650	16,-	223W10/3650	16,-	223W12/3650	17,-	223W14/3650	17,-
2530	223W06/2530	12,-	223W08/2530	12,-	223W10/2530	13,-	223W12/2530	13,-	223W14/2530	13,-
	223W06/0001	14,-	223W08/0001	15,-	223W10/0001	16,-	223W12/0001	18,-	223W14/0001	19,-

Pilové pásy sú dodávané nabrúsené, rozvedené, zvarené. Pri objednávaní iných rozmerov zvarených pásov dbajte na uvedenie správnej dĺžky pásu / stred min – max dĺžky/.

mafell	Z5Ec
mafell	Z4Ec
PROTOCOL	SBP285
INTO DARIO	SN44
INTO DARIO	SW3 MAXI
INTO DARIO	SN33
HOLZ-HER	Holz-Her

PÍLOVÉ PLÁTKY DO PRIAMOČIAREJ PÍLY

rozmer	balenie	Názov	Nr	€
100 mm	1 ks	T101B	513144870	0,63



lamino, drevo, preglejka



rozmer	balenie	Názov	Nr	€
100 mm	1 ks	T101BR	513240545	0,96



lamino, drevo, preglejka



rozmer	balenie	Názov	Nr	€
100 mm	1 ks	T101D	5112608637877	0,79



lamino, drevo, preglejka



rozmer	balenie	Názov	Nr	€
152 mm	1 ks	T344D	5112608633A34	1,25



lamino, drevo, preglejka



rozmer	balenie	Názov	Nr	€
151 mm	5 ks	L10	51386315	6,33



drevo, preglejka, pvc



rozmer	balenie	Názov	Nr	€
77 mm	5 ks	B55	513B31887	8,75



drevo, lamino



rozmer	balenie	Názov	Nr	€
59 mm	5 ks	B54	51310986	9,83



drevo, preglejka, pvc



rozmer	balenie	Názov	Nr	€
73 mm	5 ks	super express B52	51306482	5,00



drevo, preglejka, pvc



rozmer	balenie	Názov	Nr	€
155 mm	5 ks	T313AW	5034932430144	21,61

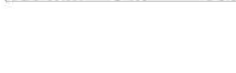

izolácie, peny, kartóny, guma



rozmer	balenie	Názov	Nr	€
50 mm	2 ks	T118AHM	5034932373393	18,70



nerez



rozmer	balenie	Názov	Nr	€
55 mm	5 ks	T118A	5034932254063	3,75



hliník, ocel



LUPIENKOVÉ LISTY

dĺžka	balenie	šírka x hrúbka	ozubenie	Nr	€
130 mm	12 ks	1,5 x 0,48 mm	drevo, plasty, plexisklo, farebné kovy	51328116	3,17
130 mm	12 ks	0,75 x 0,36 mm	hrubé	51328113	4,00
130 mm	12 ks	0,6 x 0,3 mm	kovy, pertinax	51328118	3,17
130 mm	12 ks	0,6 x 0,3 mm	drevo, plasty, plexisklo, farebné kovy	51328118	3,17
130 mm	12 ks	0,8 x 0,34 mm	veľmi jemné	51328114	4,00
130 mm	12 ks	0,8 x 0,34 mm	veľmi jemné	51328114	4,00
127 mm	12 ks	2,61 x 0,51 mm	hrubé	51328741	4,83
127 mm	12 ks	1,76 x 0,25 mm	drevo, plasty, plexisklo, drevotrieska	51328745	4,83
127 mm	12 ks	1,2 x 0,38 mm	stredné	51328117	3,17
127 mm	12 ks	1,86 x 0,24 mm	stredné	51328743	4,83
130 mm	12 ks	0,85 x 0,4 mm	stredné	51328112	4,00
130 mm	12 ks	0,85 x 0,4 mm	stredné	51328112	4,00

VEĽMI JEMNÉ

JEMNÉ

STREDNÉ

HRUBÉ



130 mm	12 ks	1,2 x 1,2 mm	drevo, plasty	okhrúhle	51328747	6,08
--------	-------	--------------	---------------	----------	----------	------



RÁMOVÉ PÍLOVÉ LISTY



L	H	b	t	Olištovanie	Nr	€
1250	160	2,0	26	30 x 140	226125016020	na dopyt
985	140	2,0	26	35 x 120	226098514020	na dopyt
1000	140	2,0	26	35 x 120	226100014020	na dopyt
1200	140	2,0	26	35 x 120	226120014020	na dopyt
1205	140	2,0	26	35 x 120	226120514020	na dopyt
1250	160	2,2	26	35 x 140	226125016022	na dopyt
1345	160	2,2	26	35 x 140	226134516022	na dopyt
1415	160	2,2	26	35 x 140	226141516022	na dopyt
1445	160	2,2	26	35 x 140	226144516022	na dopyt
1485	160	2,2	26	35 x 140	226148516022	na dopyt

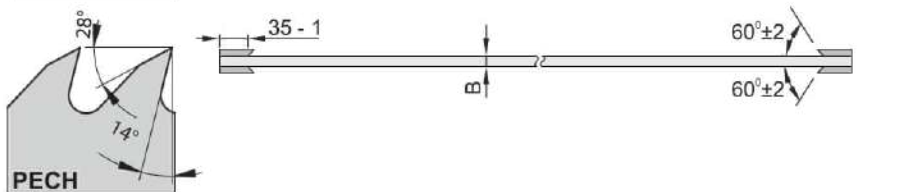
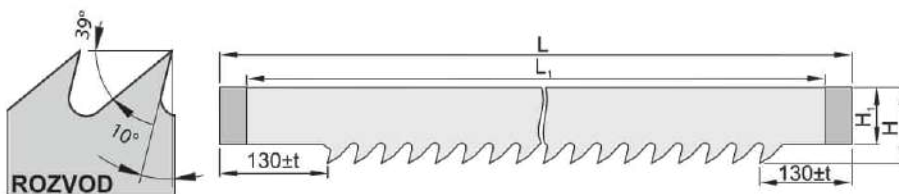

Listy sú dodávané rovnané, vystužené, nerozvedené, neostrené. Možnosť dodávania s olištovaním kalenými lištami v šírke 35,25mm alebo neolištované. Iné rozmery na objednávku.

RÁMOVÉ PÍLOVÉ LISTY - CHROMOVANÉ



L	H	b	t	Olištovanie	Nr	€
1000	140	2,0	26	35 x 120	226CR100014020	na dopyt
1200	140	2,0	26	35 x 120	226CR120014020	na dopyt
1205	140	2,0	26	35 x 120	226CR120514020	na dopyt
1415	160	2,2	26	35 x 140	226CR141516022	na dopyt
1445	160	2,2	26	35 x 140	226CR144516022	na dopyt
1485	160	2,2	26	35 x 140	226CR148516022	na dopyt

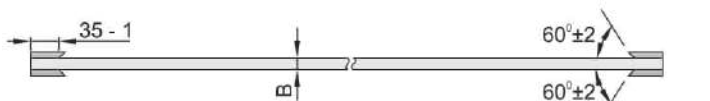
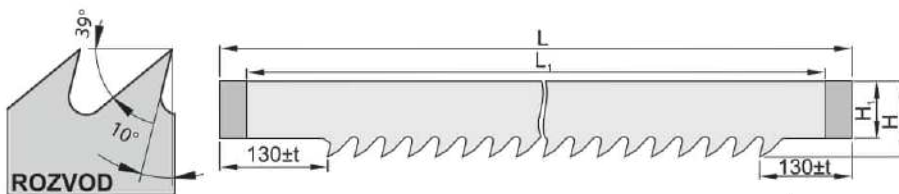

Listy sú dodávané rovnané, vystužené, nerozvedené, neostrené. Tvrdochromová vrstva zvyšuje odolnosť listu proti opotrebovaniu, chráni povrch pred koróziou a pred nalepovaním živoce. Iné rozmery na objednávku.

RÁMOVÉ PÍLOVÉ LISTY - STELITOVANÉ



L	H	b	t	Olištovanie	Nr	€
1000	140	2,0	26	35 x 120	226ST100014020	na dopyt
1205	140	2,0	26	35 x 120	226ST120514020	na dopyt
1415	160	2,2	26	35 x 140	226ST141516022	na dopyt

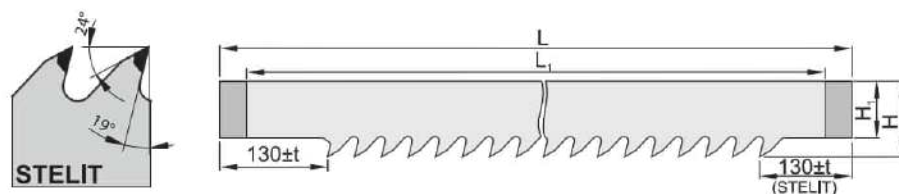

Listy sú dodávané rovnané, vystužené, nerozvedené, neostrené. Vhodné pre spracovanie odkôrneného materiálu. Životnosť ostria je až 6x vyššia oproti nestelitovanému listu. Výhodou je nízka energetická náročnosť pri rezaní, vyššia kvalita, povrchu obročku a možnosť opakovaného navarovania zubov po ich odbrúsení (cca. 15-20x ostrenie). Iné rozmery na objednávku.



C75 KMEŇOVÉ PÍLOVÉ ÚZKE PÁSY 									
H	B	t	V	€	RO	€	ROK	€	
SILVER MASTER - WM1									
35	1,0	22	227S13510V na		227S13510RO na		227S13510ROK na		
35	1,1	22	227S13511V dopyt		227S13511RO dopyt		227S13511ROK dopyt		
40	1,1	22	227S14011V		227S14011RO		227S14011ROK		
SILVER MASTER - WM2									
32	0,9	22,2	227S23209V na		227S23209RO na		227S23209ROK na		
35	1,0	22	227S23510V dopyt		227S23510RO dopyt		227S23510ROK dopyt		
35	1,1	22	227S23511V		227S23511RO		227S23511ROK		
40	1,1	22	227S24011V		227S24011RO		227S24011ROK		
GOLD MASTER - WM2									
38	1,14	22,2					227G238114ROK na		
50	1,1	22,2					227G25011ROK dopyt		

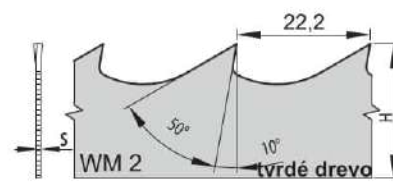
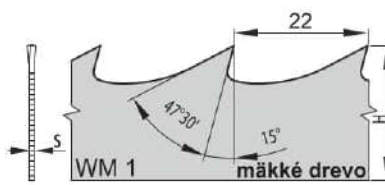

Pásy sú dodávané v 25 metrových zvitkoch s možnosťou zvárania na mieru. Materiál s obsahom chrómu a vanádu o tvrdosti 44-46HRc. Zaoblená spodná hrana proti praskaniu pásu. V-vyzubený RO-vyzubený, rozvedený, ostrený ROK-vyzubený, rozvedený, ostrený, kalený



KMEŇOVÉ PÍLOVÉ ÚZKE PÁSY - BIMETAL 				
H	B	t	ROK	€
BIMETAL - WM2				
34	0,9	22,2		na dopyt
34	1,1	22,2		na dopyt
41	1,1	22,2		na dopyt
50	1,1	22,2		na dopyt

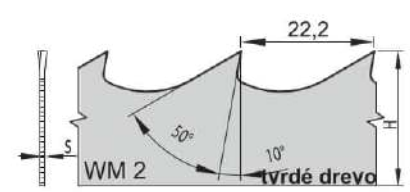

Pásy sú dodávané v 25 metrových zvitkoch s možnosťou zvárania na mieru. Materiál z pružnej legovanej ocele o tvrdosti 50HRc. Zuby HSS vo vyhotovení M42 o tvrdosti 65-67 HRc. Určenie pre rezanie veľmi tvrdého dreva. ROK-vyzubený, rozvedený, ostrený, kalený

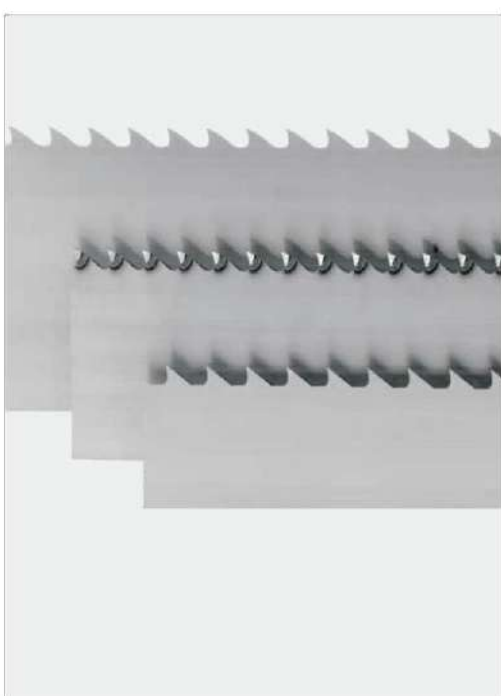

KMEŇOVÉ PÍLOVÉ PÁSY ŠIROKÉ 				
H	S	T	H1	Cena 80NiCr11
80	1	30/30	12/10	na dopyt
90	1	30/30	13/10	na dopyt
100	1,1	35/40	16/12	na dopyt
120	1,1	35/40	16/12	na dopyt
140	1,2	40/50	18/14	na dopyt
160	1,4	40/50	18/14	na dopyt
180	1,45	40/50	18/14	na dopyt
200	1,45	40/50	18/14	na dopyt

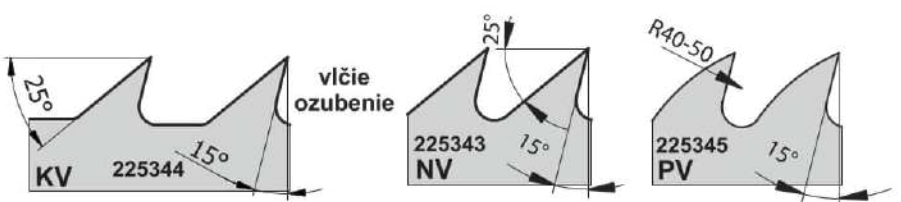

Dodávané v metráži, alebo zvarené na zákazku. Vhodné na rezanie mäkkého, tvrdého, mrazeného a exotického dreva.



AGLOMEROVANÝ KOROK

L	L	b	Nr	€
30	18 M	5	3661589116673	24,00
35	18 M	5	3661589116680	27,00
40	18 M	5	3661589116697	31,00
45	18 M	5	3661589116703	37,00
50	18 M	5	3661589116710	41,00
60	18 M	5	3661589116727	48,00

Aglomerovaný korok na obloženie kotúčov pásovej píly na drevo. Znižuje vplyv hluku. Absorbuje zmeny napätia kotúča počas pilenia.



TENZOMETER RUČNÝ PILANA

€
252,90



Pilový pás	Papätie pilového pásu	Papätie pilového pásu PSI (pre
20 x 0,9 mm	160 N.mm ⁻²	23 500
27 x 0,9 mm	180 N.mm ⁻²	26 500
34 x 1,1 mm	210 N.mm ⁻²	30 500
41 x 1,3 mm	240 N.mm ⁻²	35 000
54 x 1,3 mm	240 N.mm ⁻²	35 000
54 x 1,6 mm	280 N.mm ⁻²	40 600
67 x 1,6 mm	290 N.mm ⁻²	42 000
80 x 1,6 mm	300 N.mm ⁻²	43 500

Tenzomat Pilana určený pre pásové píly, slúži na meranie napnutia pilového pásu. Nasadzuje sa priamo na pilový pás, je teda vhodný pre pásy od rôznych výrobcov píľ.



MERADLO NA ROZVOD PÍLOVÝCH ZUBOV

merací rozsah €
2 mm 99,00

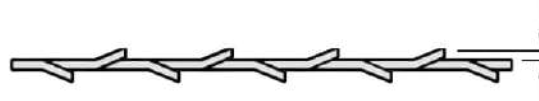

Odčítateľné z obojstranne. Merací rozsah 2 mm, zobrazovací rozsah 1 mm, odčítateľné prostredníctvom dielikov po 0,05 mm, ručička nastaviteľná na bod 0. S dodatočným, nastaviteľným krúžkom ako ukazovateľom požadovanej hodnoty. Rozmery 93 x 54 x 23 mm.



PREDREZÁVACIE PÍLOVÉ KOTÚČE PRE KMEŇOVÉ PÁSOVÉ PÍLY

L	B	d	Nr	€
180	5,0	20	22180FZ0180	45,40

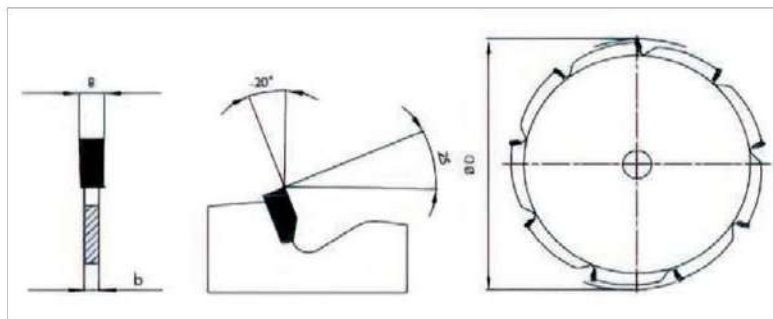

Predrezávacie kotúče odstraňujú znečistenú kôru z kmeňov v mieste rezu, pilový pás sa menej otupuje a má vyššiu životnosť.



Makita

Milwaukee

BOSCH metabo

AEG

FEIN



DEWALT

RYOBI

RIDGID

STANLEY

DREMEL

Rockwell

PARKSIDE

šírka	Nr quick	€	Nr open	€
35	275QJI035025	6,83	275OJI035025	6,13
45			275OJI045010	6,77
55			275OJI055025	7,45
65	275QJI065025	10,1	275OJI065025	8,67

šírka	Nr quick	€	Nr open	€
32	275QSB032025	10,72	275OSB032025	8,07
35	275QSB035010	10,72	275OSB035010	8,18
42	275QSB042010	11,00	275OSB042025	8,73
65	275QSB065010	11,63	275OSB065010	10,32

šírka	Nr quick	€	Nr open	€
35	275QUB035010	10,03	275OUB035010	7,69
65	275QUB065010	11,28		

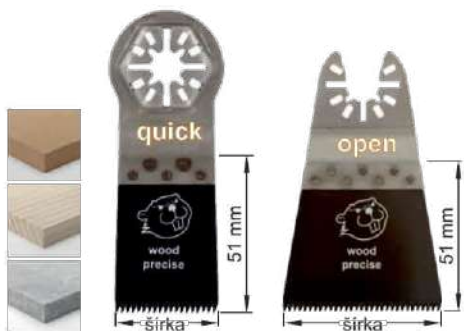

Veľmi čistá hrana, vhodné na precízne práce s masivom či preglejkou.

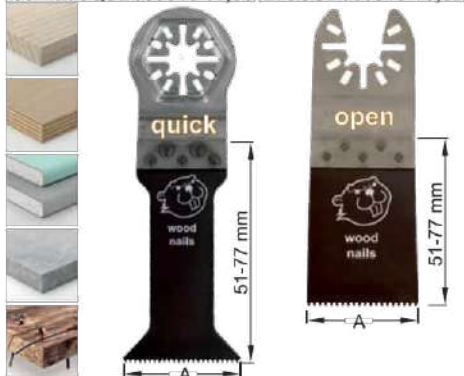

Značne odolné zuby, univerzálne aplikácie. Odporúčame mazanie pri rezaní kovov.

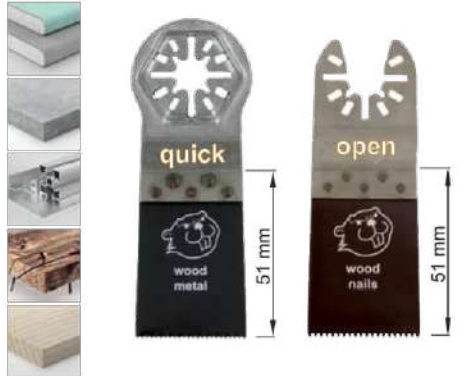

Pre rezanie kovov, pri nižších rýchlostiach. Odporúčame mazanie pri rezaní kovov.

šírka	Nr quick	€	Nr open	€
28	275QUB028025	8,45	275OUB028010	7,22
43	275QUB043025	9,16	275OUB043010	8,00

šírka	Nr quick	€	Nr open	€
35	275QUI035010	7,68	275OUI035010	6,40
65	275QUI065010	8,90	275OUI065010	8,17

šírka	Nr quick	€	Nr open	€
32	275QSI032025	7,38	275OSI032010	6,47
42	275QSI042025	8,43	275OSI042010	7,00



Pre rezanie kovov, pri nižších rýchlostiach. Odporúčame mazanie pri rezaní kovov.

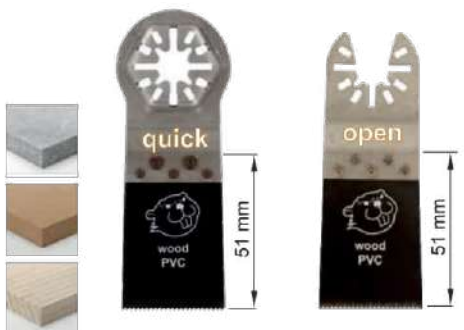

Vhodné na drevo, plasty či hliník. Nevhodné na rezanie kovov.



Hlboký a precízny rez do masívu, preglejky či lamino materiálov.

šírka	Nr quick	€	Nr open	€
32	275QRB032025	9,38	275ORB032025	8,78

šírka	Nr quick	€	Nr open	€
35	275QFM035	22,42	275OFM035	21,40

šírka	Nr quick	€
70	275QFP070	38,60



Hlboký a precízny rez do masívu, preglejky či lamino materiálov.



Rezanie silikónových spojov a rôznych tesnení. Úzky tvar pre lepší prístup do rohov.

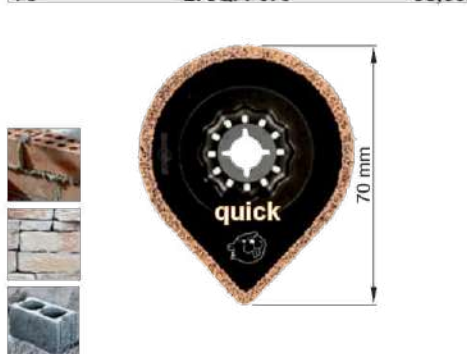

Povlak z tvrdokovu pre rýchlu a presnú prácu s kameňom, maltou či betónom.

šírka	Nr quick	€	brusivo Nr	€
92	275QSA092	15,79	40 510499161	0,39
			60 510499162	0,42
			80 510499163	0,42
			100 510499164	0,33
			120 510499165	0,33
			150 510499166	0,42



Oscilačná brúsna hlava Coram pre brusivo Festool Rubin určené najmä na masív.

šírka	Nr quick	€	Nr open	€
65	275QSS065	17,74	275OSS065	18,50



Pre odstránenie starých lepidiel, silikónov, rôznych tesnení ale aj zvyšky malty a betónu.

šírka	Nr quick	€	Nr open	€
65	275QWS065	26,88	275OWS065	22,76

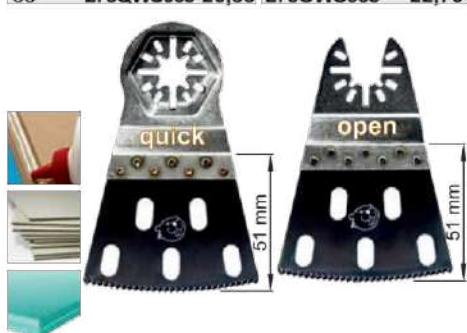

Pre rezanie izolačných materiálov, ale aj pre odstránenie starých lepidiel, silikónov či tesnení.



rozmer	balenie	Nr	€
230 mm	5 ks	50348005016	26,00



Zuby HSS s 8% kobaltu. Pre extrémne presné a rýchle rezanie s čistými hranami do dreva (bez klinčov) a do plastu

rozmer	balenie	Nr	€
150 mm	5 ks	50348005091	16,00
200 mm	5 ks	50348005293	26,33
200 mm	5 ks	50348005093	18,58



Zuby HSS s 8% kobaltu. Tuhá bimetalová konštrukcia pre rýchly rez a dlhú životnosť listu. Univerzálne použitie.

rozmer	balenie	Nr	€
150 mm	5 ks	50348005182	12,42
300 mm	5 ks	50348005189	21,58



Zuby HSS s 8% kobaltu. Lisované zárezy v mieste upínania zosilňujú list v jeho najslabšom mieste. Prerez 0,9 mm.

rozmer	balenie	Nr	€
150 mm	5 ks	50348005184	12,17
230 mm	5 ks	50348005187	17,33



Zuby HSS s 8% kobaltu. Lisované zárezy v mieste upínania zosilňujú list v jeho najslabšom mieste. Prerez 0,9 mm.

rozmer	balenie	Nr	€
230 mm	5 ks	50348005188	17,42



Zuby HSS s 8% kobaltu. Lisované zárezy v mieste upínania zosilňujú list v jeho najslabšom mieste. Prerez 0,9 mm.

rozmer	balenie	Nr	€
150 mm	5 ks	50348005782	16,58
230 mm	5 ks	50348005787	20,75

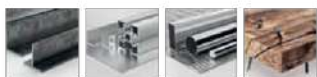

Pilový list s hrúbkou 1,06 mm na presné pílenie do plechu a rúrok. 25mm výška pre lepšiu stabilitu a zníženie vibrácií.

rozmer	balenie	Nr	€
150 mm	5 ks	50448005021	xxx
230 mm	5 ks	50448005026	
300 mm	5 ks	50448005027	



Zuby HSS s 8% kobaltu. Geometria chráni zuby pri náraze na kliniec, hrúbka 1,6 mm zaisťuje maximálnu robustnosť.

rozmer	balenie	Nr	€
230 mm	5 ks	50448005036	xxx



Zuby HSS s 8% kobaltu. Geometria chráni zuby pri náraze na kliniec, hrúbka 1,25 mm ho určuje na presnejšiu prácu.

rozmer	balenie	Nr	€
450 mm	1 ks	50348001460	44,50



Pilový list na rezanie stavebných materiálov. Maximálne kapacity rezania sú: 350 mm pri armovanom betóne a tehle.

rozmer	balenie	Nr	€
230 mm	1 ks	50348001450	19,50



Pilový list s diamantovými zubami. Maximálne kapacity rezania: Priemer 160 mm pri kovových aj liatinových rúrach.

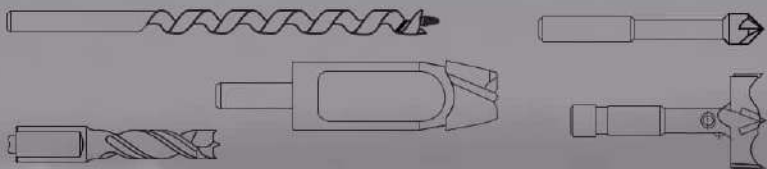

VRTÁKY



eshop.woodb.sk



STROJE

NÁSTROJE

NÁRADIE

KOVANIE

CHÉMIA

SPOJOVACÍ MATERIAL

DIELŇA

DOM-ZÁHRADA

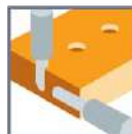
*Kolíkovacie vrtáky*

5.1

*Terasové vrtáky*

5.19

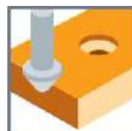
*Záhľbníky do dreva*

5.9 , 5.12 , 5.13 , 5.18

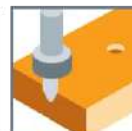
*Hĺbkové dorazy*

5.20

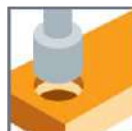
*Sukovníky*

5.7 , 5.15 , 5.17

*Predlžovacie tyče*

5.15

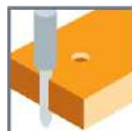
*Vrtáky do masívu*

5.11

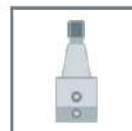
*Kolíkovacie redukcie*

5.10

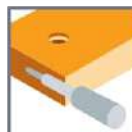
*Špeciálne vrtáky*

5.19

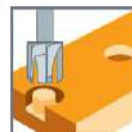
*Zátkovníky*

5.17

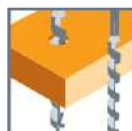
*Tesárske vrtáky*

5.13

*Staviteľné vykružovače*

5.20

*Korunkové vrtáky*

5.23

Máme vrtáky pre
remeselné i
priemyselné nároky



Druhy kolíkových vrtákov pre nepriebežné otvory

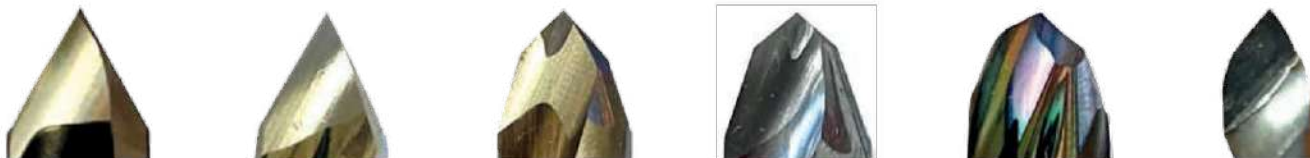

Druhy kolíkových vrtákov pre priebežné otvory



Druhy sukovníkov

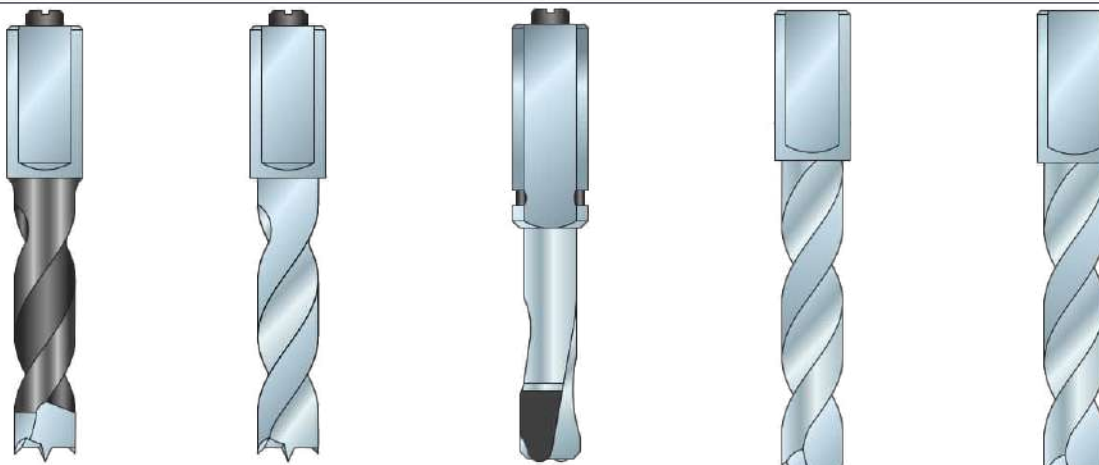

HW

HW solid

DIA

HS

SP

Druhy materiálov



Druh stroja

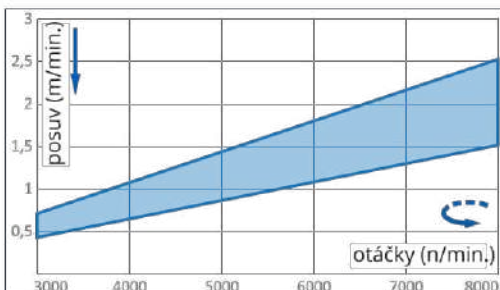

Závislosť otáčok a posuvu

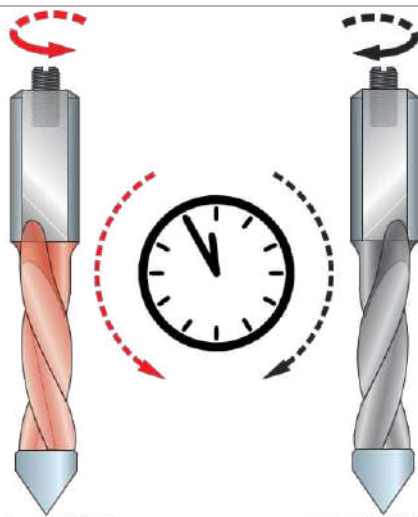

ľavotočivé

pravotočivé

Smer otáčania

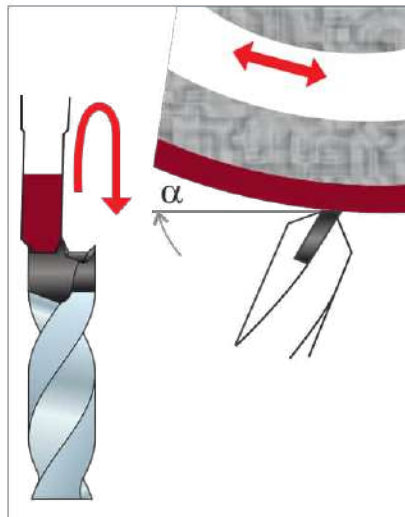

Ostrenie vrtákov



TYP 308		dĺžka L=57,5mm		
ø D	B	Nr RH	Nr LH	€
3,5	27	231.308.035.11	231.308.035.12	18,70
4	27	231.308.040.11	231.308.040.12	10,89
4,5	27	231.308.045.11	231.308.045.12	11,55
5	30	231.308.050.11	231.308.050.12	9,35
5,5	30	231.308.055.11	231.308.055.12	17,05
6	30	231.308.060.11	231.308.060.12	9,79
6,4	30	231.308.064.11	231.308.064.12	18,29
7	30	231.308.070.11	231.308.070.12	10,56
7,5	30	231.308.075.11	231.308.075.12	17,88
8	30	231.308.080.11	231.308.080.12	9,93
8,2	30	231.308.082.11	231.308.082.12	23,80
8,5	30	231.308.085.11	231.308.085.12	13,31
9	30	231.308.090.11	231.308.090.12	12,50
9,5	30	231.308.095.11	231.308.095.12	16,68
10	30	231.308.100.11	231.308.100.12	11,33
11	30	231.308.110.11	231.308.110.12	22,87
12	30	231.308.120.11	231.308.120.12	13,31
12,7	30	231.308.127.11	231.308.127.12	33,66
13	30	231.308.130.11	231.308.130.12	29,50
14	30	231.308.140.11	231.308.140.12	20,50
15	30	231.308.150.11	231.308.150.12	21,67
16	30	231.308.160.11	231.308.160.12	25,20

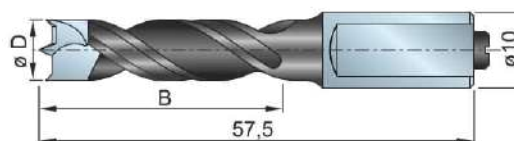

TYP 309		dĺžka L=70mm		
ø D	B	Nr RH	Nr LH	€
3,5	40	231.309.035.11	231.309.035.12	20,37
4	40	231.309.040.11	231.309.040.12	11,77
4,5	40	231.309.045.11	231.309.045.12	12,21
5	43	231.309.050.11	231.309.050.12	10,40
5,5	43	231.309.055.11	231.309.055.12	15,22
6	43	231.309.060.11	231.309.060.12	10,56
6,4	43	231.309.064.11	231.309.064.12	16,47
7	43	231.309.070.11	231.309.070.12	11,33
7,5	43	231.309.075.11	231.309.075.12	19,10
8	43	231.309.080.11	231.309.080.12	10,63
8,2	43	231.309.082.11	231.309.082.12	21,20
8,5	43	231.309.085.11	231.309.085.12	13,53
9	43	231.309.090.11	231.309.090.12	12,21
9,5	43	231.309.095.11	231.309.095.12	19,00
10	43	231.309.100.11	231.309.100.12	11,99
11	43	231.309.110.11	231.309.120.12	25,40
12	43	231.309.110.11	231.309.120.12	25,40
12,7	43	231.309.127.11	231.309.127.12	28,60
13	43	231.309.130.11	231.309.130.12	41,00
14	43	231.309.140.11	231.309.140.12	21,67
15	43	231.309.150.11	231.309.150.12	22,88
16	43	231.309.160.11	231.309.160.12	23,98

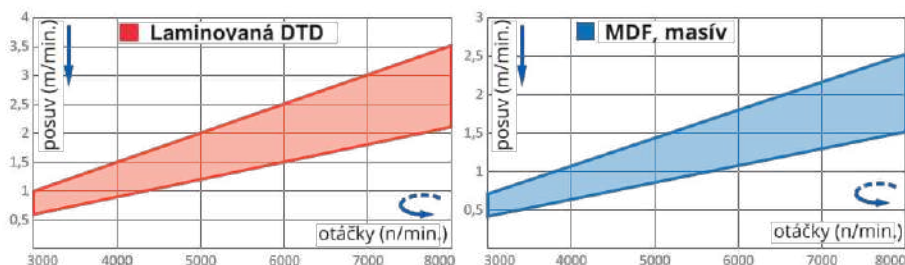
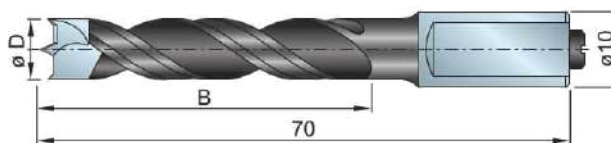

Základný typ kolíkových vrtákov na nepriebežné otvory. Klasická geometria reznej časti s ostrými predrezmi a s ich negatívnym sklonom. Upínacia stopka s plôškou. Priemerná životnosť 1500-2000 otvorov.



KOLÍKOVACIE VRTÁKY - LASER

METAL-WORLD

HW



TYP 310.4		dĺžka L=57,5mm		
ø D	B	Nr RH	Nr LH	€
5	27	231.310.050.41	231.310.050.42	11,11
6	27	231.310.060.41	231.310.060.42	11,33
7	27	231.310.070.41	231.310.070.42	15,90
8	27	231.310.080.41	231.310.080.42	11,78
10	27	231.310.100.41	231.310.100.42	14,41
12	27	231.310.120.41	231.310.120.42	24,26

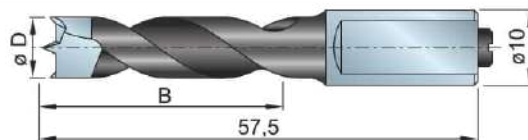

TYP 311.4		dĺžka L=70mm		
ø D	B	Nr RH	Nr LH	€
5	35	231.311.050.41	231.311.050.42	11,33
6	35	231.311.060.41	231.311.060.42	13,40
7	35	231.311.070.41	231.311.070.42	20,91
8	35	231.311.080.41	231.311.080.42	13,53
10	35	231.311.100.41	231.311.100.42	14,85
12	35	231.311.120.41	231.311.120.42	25,06

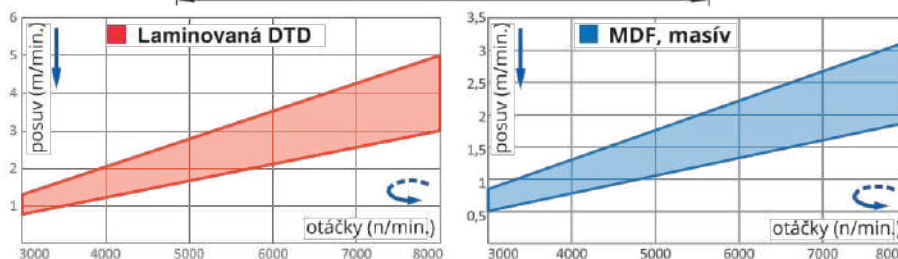
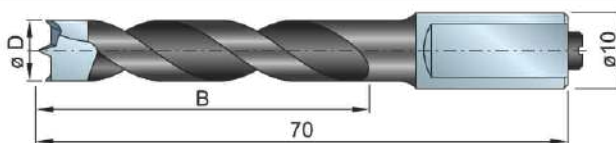

Technicky vyspelejší typ kolíkovacích vrtákov na nepriebežné otvory. Geometria reznej časti s oblými predrezmi pre vyššiu životnosť nástroja a presnejší otvor. Úpinacia stopka s ploškou. Priemerná životnosť 3500-5000 otvorov.



KOLÍKOVACIE VRTÁKY - ELICA

METAL-WORLD

HW



TYP 310.2		dĺžka L=57,5mm		
ø D	B	Nr RH	Nr LH	€
3	18	231.310.030.21	231.310.030.22	11,99
4	22	231.310.040.21	231.310.040.22	13,31
5	22	231.310.050.21	231.310.050.22	14,85
6	22	231.310.060.21	231.310.060.22	16,39
8	22	231.310.080.21	231.310.080.22	21,34
10	22	231.310.100.21	231.310.100.22	22,88

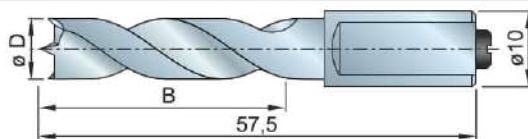

TYP 311.2		dĺžka L=70mm		
ø D	B	Nr RH	Nr LH	€
3	22	231.311.030.21	231.311.030.22	12,43
4	27	231.311.040.21	231.311.040.22	13,75
5	35	231.311.050.21	231.311.050.22	15,29
6	35	231.311.060.21	231.311.060.22	16,83
8	35	231.311.080.21	231.311.080.22	21,89
10	35	231.311.100.21	231.311.100.22	25,30

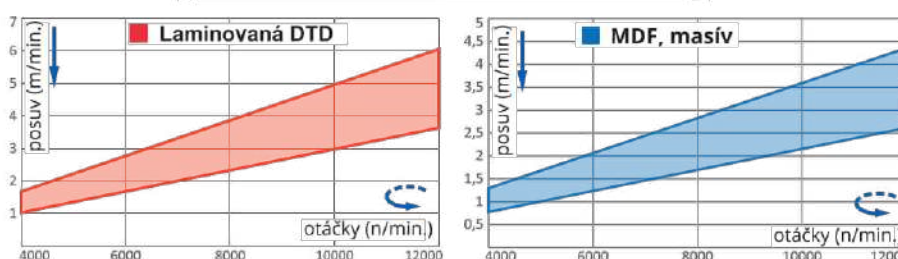
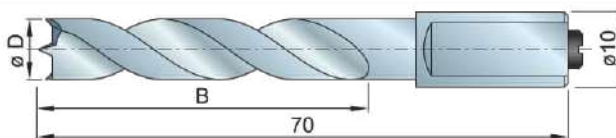

Výkonové vrtáky na nepriebežné otvory. Geometria reznej časti s oblými predrezmi a tvrdokovovým telom nástroja zlučujú požiadavky na vysokú kvalitu otvoru, stabilitu nástroja a jeho životnosť. Úpinacia stopka s ploškou. Priemerná životnosť 7000-8000 otvorov.





TYP 373		dĺžka L=85mm		HW
ø D	B	Nr RH	Nr LH	€
5	50	231.373.050.11	231.373.050.12	16,61
6	50	231.373.060.11	231.373.060.12	17,71
8	50	231.373.080.11	231.373.080.12	19,90
10	50	231.373.100.11	231.373.100.12	21,02
12	50	231.373.120.11	231.373.120.12	23,32

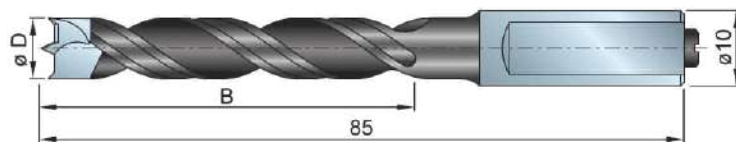

TYP 372		dĺžka L=105mm		HW
ø D	B	Nr RH	Nr LH	€
5	65	231.372.050.11	231.372.050.12	26,80
6	65	231.372.060.11	231.372.060.12	20,46
8	65	231.372.080.11	231.372.080.12	22,11
10	65	231.372.100.11	231.372.100.12	24,20
12	65	231.372.120.11	231.372.120.12	25,40

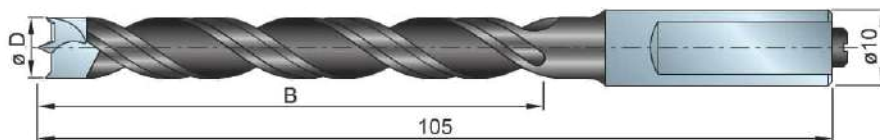

Predĺžené verzie kolíkovacích vrtákov na hlboké nepriebežné otvory. Klasická geometria reznej časti s ostrými predrezmi a s ich negatívnym sklonom. Upínacia stopka s ploškou. Odporúčame vrtanie v postupných krokoch pre zabezpečenie dobrého odvodu triesky.



TYP 306		dĺžka L=55,5mm		METAL WOOD-B	HW
ø D	B	Nr RH	Nr LH	€	
5	30	231.306.050.11	231.306.050.12	9,13	
6	30	231.306.060.11	231.306.060.12	10,34	
7	30	231.306.070.11	231.306.070.12	11,77	
8	30	231.306.080.11	231.306.080.12	10,60	
10	30	231.306.100.11	231.306.100.12	12,43	
12	30	231.306.120.11	231.306.120.12	13,75	

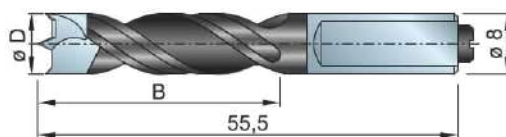

TYP 307		dĺžka L=67mm		HW
ø D	B	Nr RH	Nr LH	€
5	40	231.307.050.11	231.307.050.12	13,00
6	40	231.307.060.11	231.307.060.12	10,56
7	40	231.307.070.11	231.307.070.12	11,99
8	40	231.307.080.11	231.307.080.12	10,90
10	40	231.307.100.11	231.307.100.12	12,50
12	40	231.307.120.11	231.307.120.12	13,97

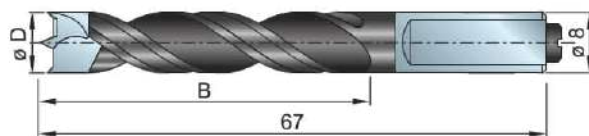

Základný typ kolíkovacích vrtákov na nepriebežné otvory. Klasická geometria reznej časti s ostrými predrezmi a s ich negatívnym sklonom. Upínacia stopka s ploškou. Určené hlavne pre vŕtacie hlavy a prípravky s malým rozstupom otvorov.



TYP P059		dĺžka L=57,5mm		
Ø D	B	Nr RH	Nr LH	€
5	22	235P059M005057R	235P059M005057L	36,96
6	22	235P059M006057R	235P059M006057L	39,16
8	22	235P059M008057R	235P059M008057L	42,30
10	22	235P059M010057R	235P059M010057L	50,70

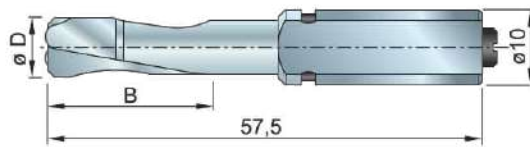

TYP P059		dĺžka L=70mm		
Ø D	B	Nr RH	Nr LH	€
5	33	235P059M005070R	235P059M005070L	37,29
6	33	235P059M006070R	235P059M006070L	39,70
8	33	235P059M008070R	235P059M008070L	43,00
10	33	235P059M010070R	235P059M010070L	51,90

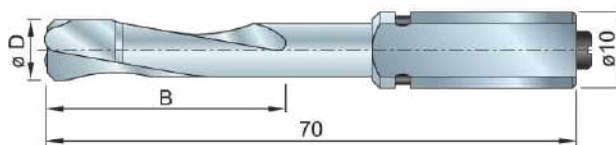

Kolíkované vrtáky s patentovanou geometriou. Vyznačujú sa presnými otvormi a extrémne dlhou životnosťou. Vďaka konštrukcii bez stredového hrotu sú vhodné na otvory blízko spodnej plochy. Zároveň však kladú vyšší dôraz na presnosť vedenia a upnutia vrtákov.



TYP 376		dĺžka L=57,5mm		
Ø D	B	Nr RH	Nr LH	€
8	12	231.376.080.11	231.376.080.12	21,34
8	15	231.376.081.11	231.376.081.12	21,34
8	20	231.376.082.11	231.376.082.12	21,34
10	12	231.376.100.11	231.376.100.12	23,10
10	15	231.376.101.11	231.376.101.12	23,10
10	20	231.376.102.11	231.376.102.12	23,10

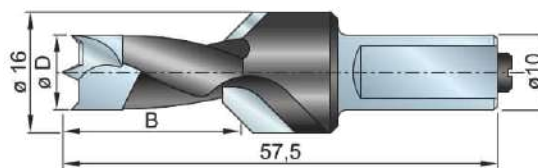

TYP 377		dĺžka L=70mm		
Ø D	B	Nr RH	Nr LH	€
8	12	231.377.080.11	231.377.080.12	21,34
8	15	231.377.081.11	231.377.081.12	21,34
8	25	231.377.084.11	231.377.084.12	23,10
10	12	231.377.100.11	231.377.100.12	23,43
10	15	231.377.101.11	231.377.101.12	23,43
10	20	231.377.102.11	231.377.102.12	24,10

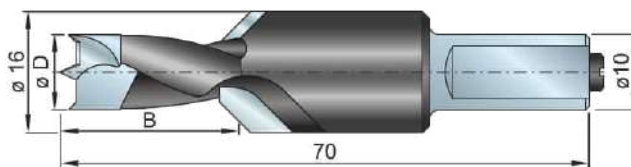

Kolíkované vrtáky s presne definovaným záhlbníkom. Záhlbená časť v dieli výrazne uľahčuje montáž kolíkov - nevznikajú na nich otrepy. Eliminuje sa vytekanie prebytočného lepidla na plochu diela.



314		PRIEBEŽNÝ VRTÁK - ŠTANDARD		METAL WORLD	HW
ø D	B	Nr RH	Nr LH	€	
4	40	231.314.040.11	231.314.040.12	19,25	
4,5	40	231.314.045.11	231.314.045.12	14,55	
5	40	231.314.050.11	231.314.050.12	12,70	
5,5	40	231.314.055.11	231.314.055.12	24,52	
6	40	231.314.060.11	231.314.060.12	14,20	
6,4	40	231.314.064.11	231.314.064.12	26,10	
7	40	231.314.070.11	231.314.070.12	15,10	
7,5	40	231.314.075.11	231.314.075.12	25,35	
8	40	231.314.080.11	231.314.080.12	14,60	
8,5	40	231.314.085.11	231.314.085.12	18,80	
9	40	231.314.090.11	231.314.090.12	28,26	
9,5	40	231.314.095.11	231.314.095.12	30,10	
10	40	231.314.100.11	231.314.100.12	15,71	
12	40	231.314.120.11	231.314.120.12	19,90	

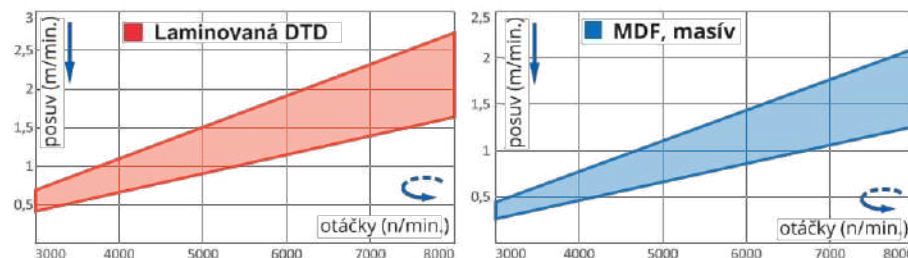
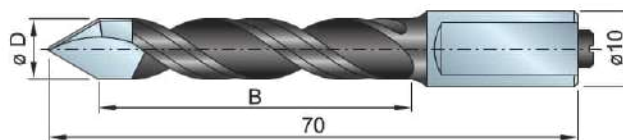

Základný typ priebežných vrtákov. Klasická geometria reznej časti. Upínacia stopka s ploškou. Možnosť kombinovať so záhlbníkom Typ 315 a Typ 316.



314M, 314L		PRIEBEŽNÉ VRTÁKY PREDĹŽENÉ		METAL WORLD	HW
TYP 314M		dĺžka L=85mm		€	
ø D	B	Nr RH	Nr LH		
5	55	231.314M.050.11	231.314M.050.12	22,87	
6	55	231.314M.060.11	231.314M.060.12	24,54	
8	55	231.314M.080.11	231.314M.080.12	26,40	
10	55	231.314M.100.11	231.314M.100.12	28,29	

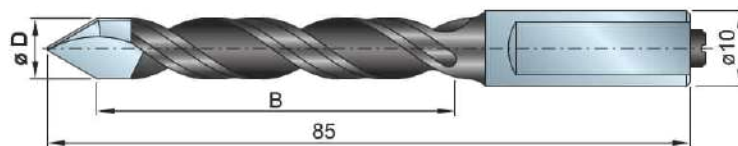

TYP 314L		dĺžka L=115mm		€	
ø D	B	Nr RH	Nr LH		
5	70	231.314L.050.11	231.314L.050.12	36,59	
6	70	231.314L.060.11	231.314L.060.12	43,00	
8	70	231.314L.080.11	231.314L.080.12	40,57	
10	70	231.314L.100.11	231.314L.100.12	45,26	

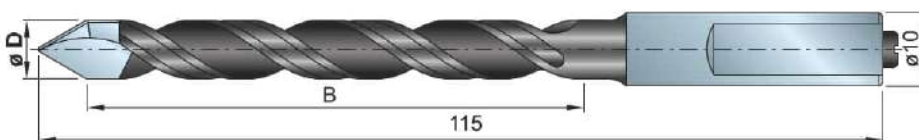

Predĺžené verzie priebežných vrtákov. Upínacia stopka s ploškou. Odporúčame vrtanie v postupných krokoch pre zabezpečenie dobrého odvodu tresky. Pre elimináciu vibrácií odporúčame v prvom kroku navádzací otvor do hĺbky 1XD predznačovacím vrtákom Typ L136 alebo L137.



314.4 PRIEBEŽNÝ VRTÁK - LASER				METAL-WORLD	HW
ø D	B	Nr RH	Nr LH	€	
5	35	231.314.050.41	231.314.050.42	14,40	
6	35	231.314.060.41	231.314.060.42	15,60	
8	35	231.314.080.41	231.314.080.42	17,50	
10	35	231.314.100.41	231.314.100.42	19,00	

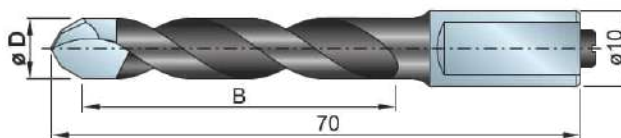

Priebežné vrtáky s lomenou zavrtávacou reznou hranou. Táto konštrukcia zvyšuje životnosť vrtákov aj kvalitu vrtaného otvoru.



314.2 PRIEBEŽNÝ VRTÁK - ELICA				METAL-WORLD	HW
ø D	B	Nr RH	Nr LH	€	
3	20	231.314.030.21	231.314.030.22	15,62	
4	25	231.314.040.21	231.314.040.22	17,27	
5	33	231.314.050.21	231.314.050.22	18,26	
6	33	231.314.060.21	231.314.060.22	21,67	
8	33	231.314.080.21	231.314.080.22	25,90	
10	33	231.314.100.21	231.314.100.22	29,70	

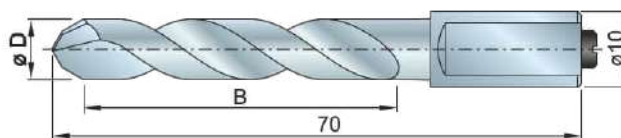

Priebežné monolitické vrtáky s lomenou zavrtávacou reznou hranou. Vrtáky sú určené na vysoké priemyselné nasadenie.



L136; L137 VRTACIE HROTY Z1				Klein SYSTEM	HW
TYP L136		dĺžka L=57,5mm			
ø D	B	Nr		€	
2	12	606L136020N		24,70	
2,5	15	606L136025N		24,70	
3	16	606L136030N		22,50	

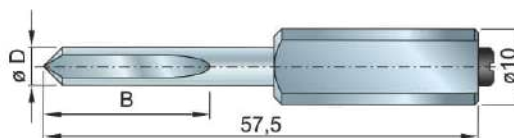

TYP L137		dĺžka L=70mm			
ø D	B	Nr		€	
2	12	606L137020N		26,74	
2,5	12	606L137025N		26,74	
3	24	606L137030N		27,46	

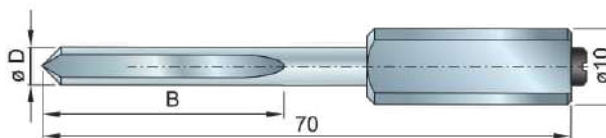

Predznačovacie monolitické vrtáky. Vrták je možné použiť ako pravotočivý aj ľavotočivý.



317 SUKOVNÍK - ŠTANDARD

HW
METAL
WORLD

HW



TYP 317		dĺžka L=57,5mm		
ø D	Nr RH	Nr LH		€
15	231.317.150.11	231.317.150.12		19,14
16	231.317.160.11	231.317.160.12		20,90
18	231.317.180.11	231.317.180.12		20,90
19	231.317.190.11	231.317.190.12		27,50
20	231.317.200.11	231.317.200.12		22,10
22	231.317.220.11	231.317.220.12		28,80
24	231.317.240.11	231.317.240.12		28,71
25	231.317.250.11	231.317.250.12		24,20
26	231.317.260.11	231.317.260.12		24,20
28	231.317.280.11	231.317.280.12		31,60
30	231.317.300.11	231.317.300.12		25,50
32	231.317.320.11	231.317.320.12		33,80
35	231.317.350.11	231.317.350.12		23,50
38	231.317.380.11	231.317.380.12		30,00
40	231.317.400.11	231.317.400.12		30,00

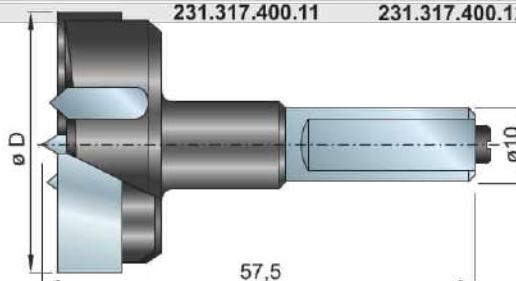

TYP 369		dĺžka L=70mm		
ø D	Nr RH	Nr LH		€
15	231.369.150.11	231.369.150.12		20,90
20	231.369.200.11	231.369.200.12		28,00
25	231.369.250.11	231.369.250.12		24,75
30	231.369.300.11	231.369.300.12		27,00
35	231.369.350.11	231.369.350.12		27,00
40	231.369.400.11	231.369.400.12		32,67

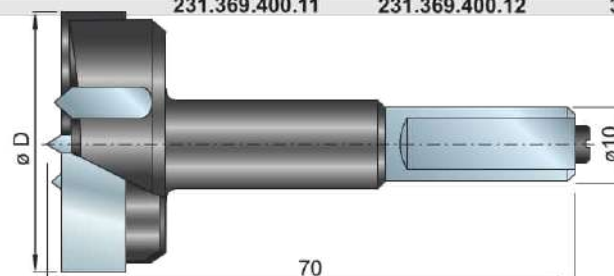

Sukovník so samostatnými negatívnymi predrezmi. Upínacia stopka s ploškou.



L155; L156 SUKOVNÍK LASER

HW



TYP L155		dĺžka L=57,5mm		
ø D	Nr RH	Nr LH		€
15	606L155150R	606L155150L		46,90
20	606L155200R	606L155200L		59,40
25	606L155250R	606L155250L		67,00
30	606L155300R	606L155300L		89,00
35	606L155350R	606L155350L		105,90

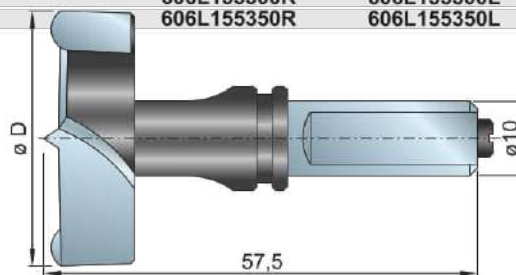

TYP L156		dĺžka L=70mm		
ø D	Nr RH	Nr LH		€
15	606L156150R	606L156150L		48,90
20	606L156200R	606L156200L		61,90
25	606L156250R	606L156250L		69,90
30	606L156300R	606L156300L		93,40
35	606L156350R	606L156350L		90,70

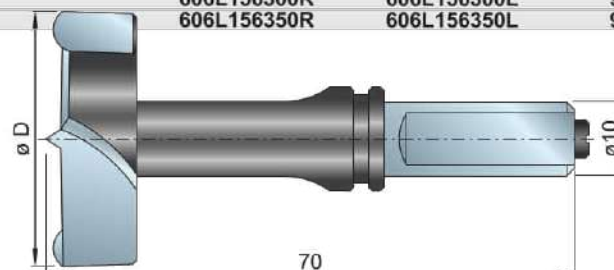

Špeciálna tvrdokovová vŕtacia korunka umožňuje vynikajúci odvod triesky. Oblé predrezy zabezpečujú vysokú kvalitu obrábania a dávajú sukovníku dlhú životnosť.



341; 342; 343 **KOLÍKOVACÍ VRTÁK ŠTANDARD M10x30°** HW

TYP 341		dĺžka L=55mm M10x30°		
ø D	B	Nr RH	Nr LH	€
5	30	231.341.050.11	231.341.050.12	25,90
6	30	231.341.060.11	231.341.060.12	25,90
8	30	231.341.080.11	231.341.080.12	27,10
10	30	231.341.100.11	231.341.100.12	27,10
12	30	231.341.120.11	231.341.120.12	29,55

TYP 342		dĺžka L=65mm M10x30°		
ø D	B	Nr RH	Nr LH	€
5	40	231.342.050.11	231.342.050.12	28,30
6	40	231.342.060.11	231.342.060.12	28,30
8	40	231.342.080.11	231.342.080.12	29,40
10	40	231.342.100.11	231.342.100.12	29,40
12	40	231.342.120.11	231.342.120.12	31,90

TYP 343		dĺžka L=75mm M10x30°		
ø D	B	Nr RH	Nr LH	€
5	50	231.343.050.11	231.343.050.12	30,70
6	50	231.343.060.11	231.343.060.12	30,70
8	50	231.343.080.11	231.343.080.12	31,80
10	50	231.343.100.11	231.343.100.12	31,80
12	50	231.343.120.11	231.343.120.12	34,30

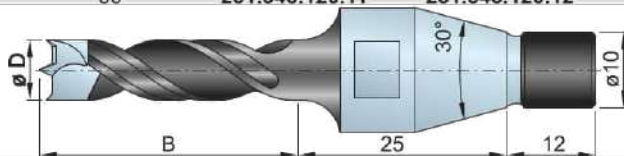

Štandardné kolíkovacie vrtáky s integrovaným upinaním - kužel a závit M10.
Vyššia presnosť, stabilita a životnosť vrtákov vďaka eliminácii upínacej redukcie.



352; 353; 353; 353L80 **KOLÍKOVACÍ VRTÁK ŠTANDARD M8/9** HW

TYP 352		dĺžka L=45mm M8/9		
ø D	B	Nr RH	Nr LH	€
5	30	231.352.050.11	231.352.050.12	25,82
6	30	231.352.060.11	231.352.060.12	25,92
8	30	231.352.080.11	231.352.080.12	39,60
10	30	231.352.100.11	231.352.100.12	27,14
12	30	231.352.120.11	231.352.120.12	22,02

TYP 353		dĺžka L=55mm M8/9		
ø D	B	Nr RH	Nr LH	€
5	40	231.353.050.11	231.353.050.12	26,60
6	40	231.353.060.11	231.353.060.12	26,60
8	40	231.353.080.11	231.353.080.12	35,90
10	40	231.353.100.11	231.353.100.12	36,30
12	40	231.353.120.11	231.353.120.12	31,60

TYP 353L80		dĺžka L=100mm M8/9		
ø D	B	Nr RH	Nr LH	€
6	80	231.353.L80.060.11	231.353.L80.060.12	40,64
8	80	231.353.L80.080.11	231.353.L80.080.12	43,05
10	80	231.353.L80.100.11	231.353.L80.100.12	45,57
12	80	231.353.L80.120.11	231.353.L80.120.12	51,35

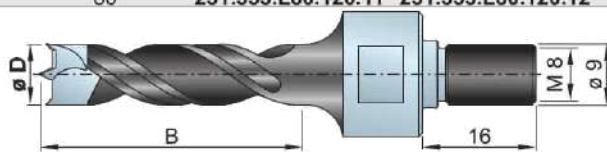

Štandardné kolíkovacie vrtáky s integrovaným upinaním - závit M8 a nákrúžok D9.
Vyššia presnosť, stabilita a životnosť vrtákov vďaka eliminácii upínacej redukcie.



340, 340L **KOLÍKOVACÍ VRTÁK ŠTANDARD M10/11** HW

TYP 340		dĺžka L=65mm M10/11		
ø D	B	Nr RH	Nr LH	€
5	50	231.340.050.11	231.340.050.12	34,30
6	50	231.340.060.11	231.340.060.12	34,30
8	50	231.340.080.11	231.340.080.12	38,20
10	50	231.340.100.11	231.340.100.12	31,80
12	50	231.340.120.11	231.340.120.12	38,40

TYP 340L		dĺžka L=95mm M10/11		
ø D	B	Nr RH	Nr LH	€
5	80	231.340.L80.050.11	231.340.L80.050.12	79,00
6	80	231.340.L80.060.11	231.340.L80.060.12	82,40
8	80	231.340.L80.080.11	231.340.L80.080.12	84,00
10	80	231.340.L80.100.11	231.340.L80.100.12	85,70
12	80	231.340.L80.120.11	231.340.L80.120.12	87,00

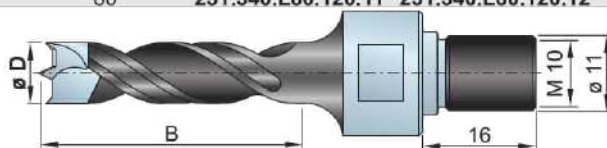

Štandardné kolíkovacie vrtáky s integrovaným upinaním - závit M10 a nákrúžok D11.
Vyššia presnosť, stabilita a životnosť vrtákov vďaka eliminácii upínacej redukcie.

315		ZÁHLBNÍK 45° NA STOPKU S10		HW	
ø d	ø D	Nr RH	Nr LH	€	
5 - 10	20	231.315.200.11	231.315.200.12	24,80	
11 - 12	22	231.315.220.11	231.315.220.12	27,00	

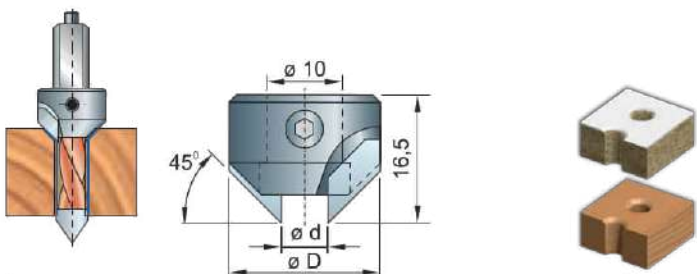

45°záhlbník sa upevňuje na stopku hlavne priebežných vrtákov so stopkou Ø10mm. Pri použití na kolíkovacom vrtáku nie je možné dĺžkové nastavenie záhlbníka na vrtáku.

316		ZÁHLBNÍK 45° NA TELO VRTÁKA		HW	
ø d	ø D	Nr RH	Nr LH	€	
4	15,5	231.316.040.11	231.316.040.12	18,00	
5	15,5	231.316.050.11	231.316.050.12	18,00	
6	15,5	231.316.060.11	231.316.060.12	18,00	
7	18	231.316.070.11	231.316.070.12	19,00	
8	18	231.316.080.11	231.316.080.12	19,00	
9	18	231.316.090.11	231.316.090.12	19,00	
10	20	231.316.100.11	231.316.100.12	19,45	
12	22	231.316.120.11	231.316.120.12	19,45	

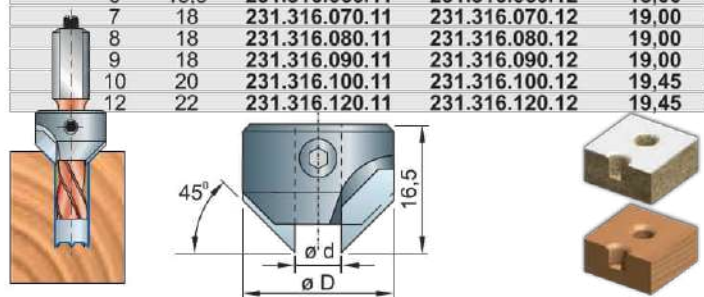

45°záhlbník sa upevňuje na telo vrtáka. Umožňuje jeho zafixovanie na požadovanej dĺžke kolíkovacích aj priebežných vrtákov. Priemer záhlbníka musí byť totožný s priemerom vrtáka.

SYSTEM SOLID

TYP 363		PRIEBEŽNÝ VRTÁK SOLID		HW	
ø D	B	L	Nr RH	Nr LH	€
2	18	49	231.363.020.11	231.363.020.12	8,10
2,5	22	55	231.363.025.11	231.363.025.12	8,90
3	22	55	231.363.030.11	231.363.030.12	9,20
3,2	22	55	231.363.032.11	231.363.032.12	17,00
3,5	25	55	231.363.035.11	231.363.035.12	10,80
4	25	55	231.363.040.11	231.363.040.12	11,40
4,5	28	58	231.363.045.11	231.363.045.12	22,50
5	28	58	231.363.050.11	231.363.050.12	12,10
6	28	58	231.363.060.11	231.363.060.12	29,40



Celotvrdokovový priebežný vrták. Možnosť kombinovať so záhlbníkom P094, prípadne použiť ako samostatný vrták v púzdra SOLID alebo redukcií SOLID.

TYP 363		KOLÍKOVACÍ VRTÁK SOLID		HW	
ø D	B	L	Nr RH	Nr LH	€
2	18	49	231.363.020.21	231.363.020.22	11,50
2,5	22	55	231.363.025.21	231.363.025.22	12,26
3	22	55	231.363.030.21	231.363.030.22	12,42
3,5	25	55	231.363.035.21	231.363.035.22	14,10
4	25	55	231.363.040.21	231.363.040.22	14,17
4,5	28	58	231.363.045.21	231.363.045.22	20,78
5	28	58	231.363.050.21	231.363.050.22	18,33
6	28	58	231.363.060.21	231.363.060.22	25,76



Celotvrdokovový kolíkovací vrták. Možnosť kombinovať so záhlbníkom P094, prípadne použiť ako samostatný vrták v púzdra SOLID, alebo redukcií SOLID.

365		REDUKCIE SOLID		HW	
ø D	Nr	€			
2	231.365.020.00	8,90			
2,5	231.365.025.00	8,90			
3	231.365.030.00	8,90			
3,2	231.365.032.00	8,90			
3,5	231.365.035.00	8,90			
4	231.365.040.00	8,90			
4,5	231.365.045.00	9,40			
5	231.365.050.00	9,40			
6	231.365.060.00	9,50			

Jednoduchá delená redukcia na upínanie vrtákov SOLID v upínaních púzdрах a rýchloupínaných vrtáčich strojov.

364		PÚZDRA SOLID		HW	
ø D	Nr	€			
2	231.364.020.00	10,20			
2,5	231.364.025.00	10,20			
3	231.364.030.00	10,20			
3,2	231.364.032.00	10,20			
3,5	231.364.035.00	10,20			
4	231.364.040.00	10,20			
4,5	231.364.045.00	10,60			
5	231.364.050.00	10,60			
6	231.364.060.00	11,50			

Samostatné púzdra na upínanie vrtákov SOLID v upínaních púzdрах a rýchloupínaných vrtáčich strojov. Vrták je v púzdra fixovaný skrutkou.

P094		ZÁHLBNÍK 45° SOLID		HW	
ø D	Nr RH	Nr LH	€		
3	235P094M30AAAAAR	235P094M30AAAAAL	32,80		
3,5	235P094M35AAAAAR	235P094M35AAAAAL	32,80		
4	235P094M40AAAAAR	235P094M40AAAAAL	32,80		
4,5	235P094M45AAAAAR	235P094M45AAAAAL	32,80		
5	235P094M50AAAAAR	235P094M50AAAAAL	32,80		
5,5	235P094M55AAAAAR	235P094M55AAAAAL	32,80		
6	235P094M60AAAAAR	235P094M60AAAAAL	32,80		

45°záhlbník s upínacou stopkou s ploškou, pre vložený vrták. V kombinácii s vrtákom SOLID ide o univerzálnu kombináciu pre priebežné aj nepriebežné otvory so zahľbením.

P080		ZÁHLBNÍK STUPŇOVITÝ 90° SOLID		HW	
ø d	ø D	Nr RH	Nr LH	€	
4	10	235P080M0410R	235P080M0410L	74,00	
4	12	235P080M0412R	235P080M0412L	74,00	
5	12	235P080M0512R	235P080M0512L	74,00	
5	16	235P080M0516R	235P080M0516L	74,00	
6	15	235P080M0615R	235P080M0615L	74,00	
6	20	235P080M0620R	235P080M0620L	74,00	

Ploché záhlbník na telo vrtáka pre stupňovité otvory. Umožňuje jeho zafixovanie na požadovanej dĺžke kolíkovacích aj priebežných vrtákov. Vnútny priemer záhlbníka musí byť totožný s priemerom vrtáka.



Upínacia stopka

Tvar hrotu

Tvar otvoru

Stupňovitý vrták

Vrták

Kombináciou upínacej stopky, tvaru hrotu a jeho materiálu, zmyslu otáčok a definovaním rozmerov vyberiete svoj zákazkový vrták.

REDUKCIE A RÝCHLOUPÍNÁKY PRE KOLIKOVAČKY A CNC STROJE

REDUKCIA ø8/M10	€	REDUKCIA ø10/M10	€	REDUKCIA ø8/M8/9	€
RH 231.302.080.01	12,00	RH 231.302.000.01	10,10	RH 231.358.080.01	9,80
LH 231.302.080.02	12,00	LH 231.302.000.02	10,10	LH 231.358.080.02	9,80
REDUKCIA ø10/M8/9	€	REDUKCIA ø8/M10/11	€	REDUKCIA ø10/M10/11	€
RH 231.358.000.01	8,50	RH 231.305.080.01	11,30	RH 231.305.000.01	10,00
LH 231.358.000.02	8,50	LH 231.305.080.02	11,30	LH 231.305.000.02	10,00
REDUKCIA KUŽELOVÁ ø10/M8	€	REDUKCIA KUŽELOVÁ ø8/M10	€	REDUKCIA KUŽELOVÁ ø10/M10	€
RH 231.304.000.01	11,20	RH 231.303.080.01	11,90	RH 231.303.000.01	9,50
LH 231.304.000.02	11,20	LH 231.303.080.02	11,90	LH 231.303.000.02	9,50
RÝCHLOUPÍNÁK BIESSE	€	RÝCHLOUPÍNÁK MORBIDELLI	€	RÝCHLOUPÍNÁK MINIMAX	€
RH 606L030100R	19,00	514L031100R	25,30	514L032200R	26,70
LH 606L030100L	12,00				
RÝCHLOUPÍNÁK VITAP	€	RÝCHLOUPÍNÁK WEEKE	€	UPÍNACIA SKRUTKA WEEKE	€
514L033100R	25,70	606L040100R	28,60	606Z051505R	3,90



120		VRTÁK DO DREVA ŠTANDARD		FISCH	SP
ø D	B	L	ø d	Nr	€
3	30	61	3	231F01200300	2,13
4	40	75	4	231F01200400	2,13
5	50	86	5	231F01200500	2,21
6	60	93	6	231F01200600	2,21
7	70	109	7	231F01200700	2,65
8	80	117	8	231F01200800	2,65
9	80	125	9	231F01200900	3,03
10	90	133	10	231F01201000	3,33
11	100	142	8	231F01201100	4,42
12	110	151	8	231F01201200	4,85
13	110	151	10	231F01201300	5,80
14	120	160	10	231F01201400	6,43
15	120	162	10	231F01201500	7,06
16	120	162	10	231F01201600	8,09
18	130	185	10	231F01201800	12,89
20	140	205	13	231F01202000	16,69



Vrták do dreva so strediacim hrotom z nástrojovej ocele pre nenáročné používanie.

0154		VRTÁK S PREDĹŽENÝM STREDOVÝM HROTOM		FISCH	HSS
ø D	B	L	B1	Nr	€
20	135	210	12	231F015420008	126,28
22	145	220	13	231F015422008	149,41
25	165	240	15	231F015425008	157,13
30	195	270	18	231F015430008	219,46

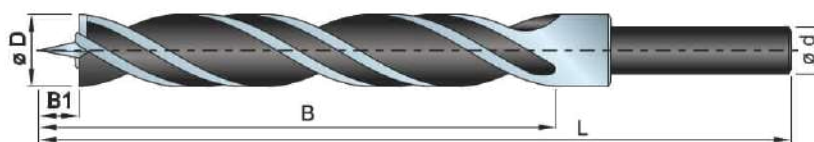

Vrták s predĺženým stredovým hrotom, ktorý slúži ako vodiaci, čím výrazne uľahčuje vrtanie pod uhlom, ako napr. vrtanie schodiskových stĺpkov.



013C		VRTÁK DO DREVA PROFI		FISCH	HSS
ŠTANDARD					
ø D	B	L	ø d	Nr	€
3	30	70	3	231F013C030070	6,19
4	43	75	4	231F013C040075	7,18
5	52	85	5	231F013C050085	8,62
6	57	95	6	231F013C060095	9,37
7	70	110	7	231F013C070110	11,48
8	70	110	8	231F013C080110	12,68
9	70	110	9	231F013C090110	14,68
10	70	110	10	231F013C100110	16,72
11	70	110	10	231F013C110110	20,07
12	70	110	10	231F013C120110	20,09
13	70	110	10	231F013C130110	25,24
14	70	110	10	231F013C140110	25,26
15	70	110	10	231F013C150110	31,94
16	100	160	10	231F013C160160	39,43
18	100	140	10	231F013C180140	41,88

PREDĹŽENÝ					
ø D	B	L	ø d	Nr	€
6	160	200	6	231F013C060200	25,97
8	160	200	8	231F013C080200	35,15
10	160	200	10	231F013C100200	37,38
12	160	200	10	231F013C120200	41,99
14	160	200	10	231F013C140200	43,90
16	160	200	10	231F013C160200	47,93
20	160	200	10	231F013C200200	58,12



Vrták do dreva so strediacim hrotom a oblými predrezmi z HSS ocele pre priemerné nasadenie. Vynikajúca kvalita otvorov aj pri vrtaní laminovaných a dýhovaných materiálov.

BIT					
ø D	B	L	Nr	€	
3	30	70	231F013BE0300	9,75	
4	35	75	231F013BE0400	9,82	
5	45	85	231F013BE0500	9,75	
6	55	95	231F013BE0600	11,13	
8	70	110	231F013BE0800	13,01	
10	70	110	231F013BE1000	17,61	
12	70	110	231F013BE1200	24,68	
sada Ø3-8			231F013BE0005	52,96	

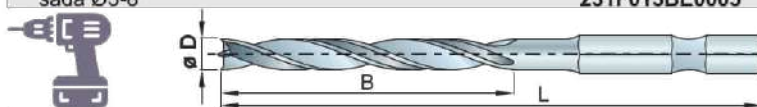

Variants upínacim šesťhranom. Vhodné pre AKU náradie.



1869		PREDĹŽENÝ ŠPIRÁLOVÝ VRTÁK 120°		HSS
ø D=d	B	L	Nr	€
3	130	190	513HSS3030	4,25
3,5	145	210	513HSS3035	4,92
4	150	220	513HSS3040	5,58
4,5	160	235	513HSS3045	5,17
5	170	245	513HSS3050	6,42
5,5	180	260	513HSS3055	6,83
6	180	260	513HSS3060	8,83
6,5	190	275	513HSS3065	9,58
7	200	290	513HSS3070	10,17
8	210	305	513HSS3080	15,50
9	220	320	513HSS3090	16,17
10	235	340	513HSS3100	18,83



Brúsený HSS špirálový vrták DIN 1869 použiteľný pre vrtanie dreva, aglomerátov, plastov a hliníka.



013P		PEN DRILL		FISCH	HSS
ø D	B	L	ø d	Nr	€
6	120	150	6	231F013P0600150	14,60
7	120	150	7	231F013P0700150	16,20
8,03	120	150	8,03	231F013P0803150	20,10
9	120	150	9	231F013P0900150	21,30
10	120	150	10	231F013P1000150	23,80
11	120	150	10	231F013P1100150	28,34
11,9	120	150	10	231F013P1190150	30,40
14	120	150	10	231F013P1400150	39,90
15	120	150	10	231F013P1500150	43,64

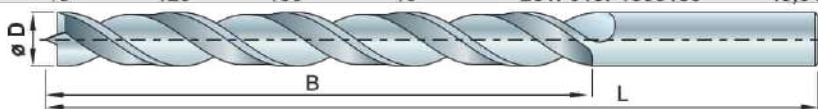

Vrták určený na vrtanie pozdĺž vlákien. Vhodný na mäkké aj tvrdé druhy dreven. Použiteľný je aj na vrtanie plastov a hliníka. Vďaka špeciálnej geometrii zanecháva vstupnú aj výstupnú hranu bez otrepov.



0639		ZÁHLBNÍK NÁSTRČNÝ 45°		FISCH	HSS
ø d	ø D	L	Nr	€	
3	16		231F06390300	10,90	
4	16		231F06390400	10,90	
5	16		231F06390500	10,90	
6	16		231F06390600	10,90	
7	20		231F06390700	12,10	
8	20		231F06390800	12,10	
10	20		231F06391000	12,70	
12	25		231F06391200	12,70	

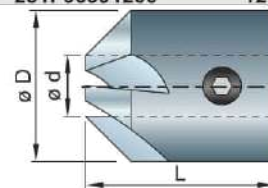

HSS záhlbník Z=5 vhodný pre všetky druhy HSS špirálových vrtákov nominálnych rozmerov.



0636		ZÁHLBNÍK NÁSTRČNÝ PLOCHÝ		FISCH	HSS
ø d	ø D	L	Nr	€	
5	14	22	231F0636050140	36,60	
5	15	22	231F0636050150	36,60	
6	15	22	231F0636060150	36,60	
8	16	25	231F0636080160	45,17	
8	20	25	231F0636080200	51,78	
8	25	25	231F0636080250	65,42	
10	20	25	231F0636100200	59,67	
10	25	25	231F0636100250	64,90	
10	30	25	231F0636100300	71,90	
12	25	25	231F0636120250	71,10	
12	30	28	231F0636120300	85,80	
12	35	32	231F0636120350	114,50	
12	40	32	231F0636120400	120,70	
12	45	38	231F0636120450	126,30	

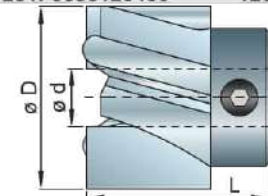

HSS záhlbník Z=2+2 vhodný pre všetky druhy HSS špirálových vrtákov nominálnych rozmerov.



TESÁRSKE HADOVITÉ VRTÁKY

FISCH

SP



0084 ŠTANDARD

ø D	B	L	ø d	Nr	€
6	250	320	6	231F0084060320	16,50
8	250	320	7	231F0084080320	16,50
10	250	320	9	231F0084100320	18,90
12	250	320	12	231F0084120320	19,40
14	250	320	12	231F0084140320	19,80
16	250	320	12	231F0084160320	20,40
18	250	320	12	231F0084180320	22,70
20	250	320	12	231F0084200320	25,40
22	250	320	12	231F0084220320	27,80
6	390	460	6	231F0084060460	27,80
8	390	460	7	231F0084080460	26,20
10	390	460	9	231F0084100460	28,00
12	390	460	12	231F0084120460	28,60
14	390	460	12	231F0084140460	30,30
16	390	460	12	231F0084160460	33,50
18	390	460	12	231F0084180460	34,90
20	390	460	12	231F0084200460	38,60
24	390	460	12	231F0084240460	47,90

Hadovitý vrták tradičnej konštrukcie s reznou hranou a vodiacim závitovým hrotom. Vyhotovením a použitým materiálom výrazne prevyšuje komunálne nástroje. Upínanie šesťhranom zamedzuje pretočeniu stopky v skľučovadle.

0089 ELITE

ø D	B	L	ø d	Nr	€
12	250	320	12	231F0089120320	21,20
14	250	320	12	231F0089140320	22,20
16	250	320	12	231F0089160320	23,40
18	250	320	12	231F0089180320	26,40
20	250	320	12	231F0089200320	29,70
22	250	320	12	231F0089220320	32,50
12	390	460	12	231F0089120460	31,40
14	390	460	12	231F0089140460	33,60
16	390	460	12	231F0089160460	37,50
18	390	460	12	231F0089180460	38,80
20	390	460	12	231F0089200460	50,00
22	390	460	12	231F0089220460	50,00
12	580	650	12	231F0089120650	53,82
14	580	650	12	231F0089140650	57,10
16	580	650	12	231F0089160650	54,20
18	580	650	12	231F0089180650	56,50
20	580	650	12	231F0089200650	63,70
22	580	650	12	231F0089220650	69,30

Hadovitý vrták prémiovej kvality. Poniklovanie celého nástroja predlžuje životnosť reznej hrany, výrazne znižuje trenie pri vrtaní hlbokých otvorov a chráni ho pred koróziou. Upínanie šesťhranom zamedzuje pretočeniu stopky v skľučovadle.

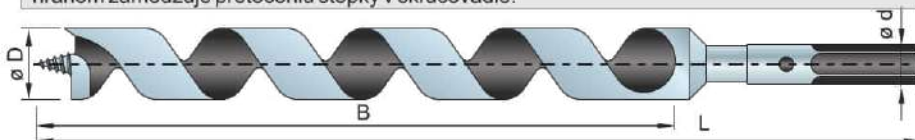
063ASW
ZÁHLBNÍK PLOCHÝ NA TESÁRSKE VRTÁKY

FISCH

SP



ø D	B	L	ø d	Nr	€
40	15	38	12	231F063ASW12040	83,10
45	15	38	12	231F063ASW12045	84,00
50	17	38	12	231F063ASW12050	84,80
62	20	38	12	231F063ASW12062	85,60
65	21	38	12	231F063ASW12065	93,60
75	23	38	12	231F063ASW12075	104,20
85	25	40	12	231F063ASW12085	111,70

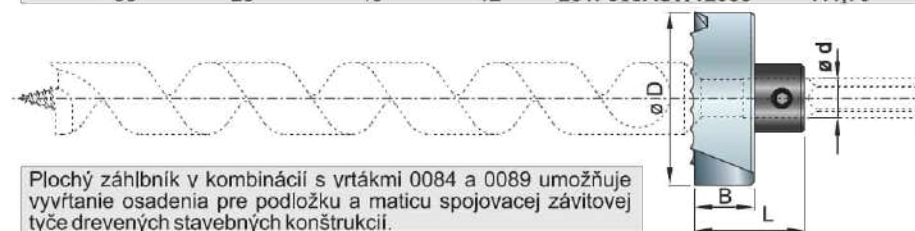

Ploché záhlbník v kombinácii s vrtákmi 0084 a 0089 umožňuje vyvrtanie osadenia pre podložku a maticu spojovacej závitovej tyče drevených stavebných konštrukcií.

629Z
PREDLŽOVACIE TYČE

FISCH

ø D	ø d	L	Nr	€
20	12	300	231F629Z0030084	49,50
26	16	300	231F629Z00300841	84,70

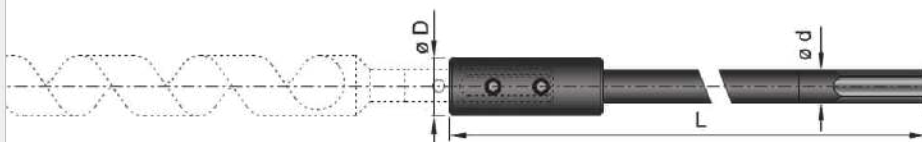



1869		FISCH	
UPÍNACIE ADAPTÉRY NA TESÁRSKY VRTÁK			
Ø D=d	Nr	€	
MAFELL	231F62900840080	45,50	
MKII	231F62900840082	45,50	
SDS	231F62900840088	45,50	

Adaptéry pre tesárske vrtáky typ 0084 a 0089, stopky 12mm, pre špecifické potreby upnutia v elektrickom ručnom náradí



0532		FISCH	SP	
LOPATKOVÝ VRTÁK				
Ø D	B	L	Nr	€
8	110	150	231F053000800	3,10
10	110	150	231F053001000	3,35
12	110	150	231F053001200	3,60
14	110	150	231F053001400	3,80
16	110	150	231F053001600	3,80
18	110	150	231F053001800	4,00
20	110	150	231F053002000	4,30
22	110	150	231F053002200	4,70
24	110	150	231F053002400	4,90
25	110	150	231F053002500	5,00
30	110	150	231F053003000	5,70
35	110	150	231F053003500	8,00
40	110	150	231F053004000	11,30
10	350	400	61210502832	7,18
12	350	400	61210502833	7,13
14	350	400	61210502835	7,13
16	350	400	61210502836	6,92
18	350	400	61210502837	7,08
20	350	400	61210502839	7,33
22	350	400	61210502840	8,00

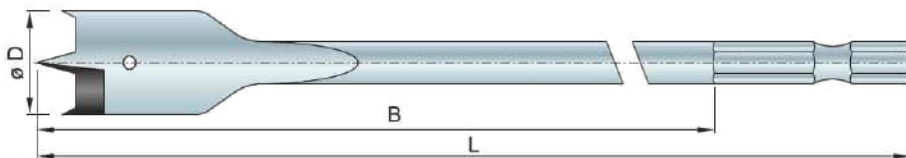

Spoločiteľné ekonomicky nenáročné vrtáky na občasnú vrtanie hlbokých otvorov bez väčšej požiadavky na kvalitu otvoru.



0100		FISCH	SP	
ŠPIRÁLOVÉ VRTÁKY NA HLBOKÉ OTVORY				
Ø D	Ø d	L	Nr	€
6	5	600	231F0100060600	8,60
8	6	600	231F0100080600	8,70
10	8	600	231F0100100600	9,80
12	8	600	231F0100120600	12,30
14	8	600	231F0100140600	14,50
16	10	600	231F0100160600	17,30
18	10	600	231F0100180600	21,40
20	10	600	231F0100200600	25,50
22	10	600	231F0100220600	35,50
24	11	600	231F0100240600	43,80
25	11	600	231F0100250600	47,20
26	11	600	231F0100260600	48,90
28	11	600	231F0100280600	52,80
30	11	600	231F0100300600	55,40
32	11	600	231F0100320600	79,90
35	11	600	231F0100350600	98,70
12	8	1000	231F0100121000	16,90
14	8	1000	231F0100141000	20,70
16	10	1000	231F0100161000	28,30
18	10	1000	231F0100181000	31,90
20	10	1000	231F0100201000	35,70
22	10	1000	231F0100221000	39,50
24	11	1000	231F0100241000	48,90
26	11	1000	231F0100261000	61,10
28	11	1000	231F0100281000	71,40
30	11	1000	231F0100301000	76,20



Určené na priebežné otvory pre stavebné konštrukcie - krovky, skelety a montáž a prípravu stavebných bední.

**0317
SUKOVNÍK WAVE**

FISCH

SP



Valcová stopka s tromi plôškami

ø D	ø d	Nr	€	ø D	ø d	Nr	€
13	8	231F031701300	17,71	32	10	231F031703200	34,30
14	8	231F031701400	19,62	33	10	231F031703300	44,60
15	8	231F031701500	22,50	34	10	231F031703400	35,90
16	8	231F031701600	22,50	35	10	231F031703500	37,10
17	8	231F031701700	21,95	36	10	231F031703600	38,20
18	8	231F031701800	23,80	38	10	231F031703800	40,80
19	8	231F031701900	25,00	40	10	231F031704000	42,90
20	8	231F031702000	25,00	42	10	231F031704200	48,80
22	8	231F031702200	25,80	44	10	231F031704400	50,50
23	8	231F031702300	26,80	45	10	231F031704500	51,80
24	8	231F031702400	26,80	46	10	231F031704600	51,80
25	8	231F031702500	28,00	48	10	231F031704800	53,80
26	8	231F031702600	28,70	50	10	231F031705000	58,60
28	8	231F031702800	29,90	51	10	231F031705100	70,40
29,6	8	231F031702963	29,00	60	10	231F031706000	95,20
30	8	231F031703000	31,50	68	10	231F031706800	120,30
				70	12	231F031707000	137,00

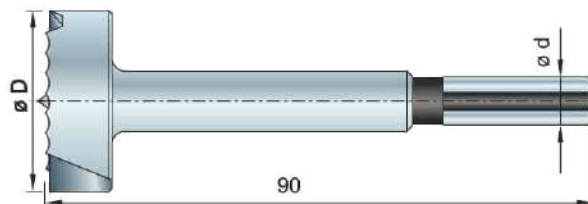

Bit

ø D	L	Nr	€
15	80	231F0317E1500	30,40
20	80	231F0317E2000	33,80
25	80	231F0317E2500	37,80
26	80	231F0317E2600	38,80
30	80	231F0317E3000	42,50
35	80	231F0317E3500	50,10

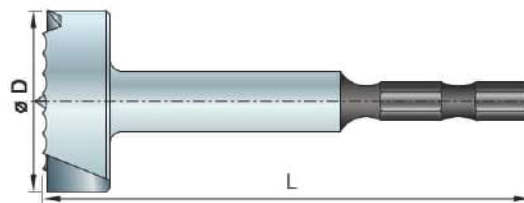

Sukovníky z nástrojovej ocele prémiovej kvality. Vďaka špeciálnemu tvaru vrtacej korunky majú výnimočné rezné vlastnosti, a dlhú životnosť. Uzatvorený tvar vrtacej korunky zároveň zvyšuje bezpečnosť obsluhy a zamedzuje zaseknutie vrtáka.

629Z 6-7 Predĺžovacia tyč

ø d	ø D	L	Nr	€
8	16	330	231F629Z006	37,70
10	18	330	231F629Z007	37,70



Predĺžovacie tyče pre sukovníky 0317 a niektoré rozmery vrtákov 013C.

**C192
SUKOVNÍK Z=2**

HW



ø D	L	ø d	Nr	€
25	57	8	606C192250R	28,00
26	57	8	606C192260R	28,00
30	57	8	606C192300R	28,90
35	57	8	606C192350R	28,90

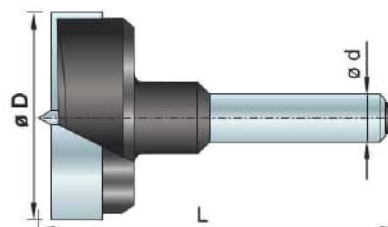

Sukovník určený na vyspravovanie hrčí pomocou hornej frézy.





205038		SUKOVNÍK S NASTAVITELNÝM HROTOM		HW
ø D	L	ø d	Nr	€
15	90	12	111183.90	67,18
20	90	12	111184.90	69,34
25	90	12	111185.90	74,62
30	90	12	111186.90	81,90
35	90	12	111187.90	85,90

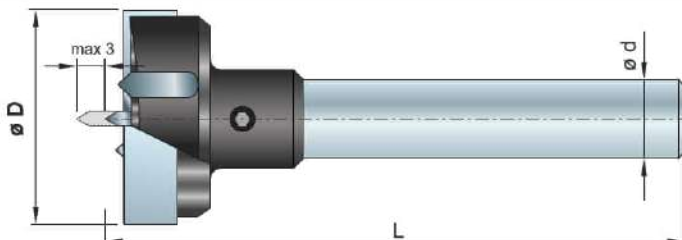

Sukovník s nastavitelným hrotom umožňujícím jeho výškový přesah voči hlavným zubom.



512		SUKOVNÍK HM		HW	
ø D	Nr	€	ø D	Nr	€
14	231.512.140.11	32,80	28	231.512.280.11	40,60
15	231.512.150.11	24,50	30	231.512.300.11	31,83
16	231.512.160.11	25,80	32	231.512.320.11	43,30
17	231.512.170.11	36,50	34	231.512.340.11	44,10
18	231.512.180.11	26,70	35	231.512.350.11	31,00
19	231.512.190.11	34,40	36	231.512.360.11	48,90
20	231.512.200.11	33,60	38	231.512.380.11	49,30
21	231.512.210.11	38,50	40	231.512.400.11	38,00
22	231.512.220.11	37,30	42	231.512.420.11	62,30
23	231.512.230.11	40,50	45	231.512.450.11	65,10
24	231.512.240.11	38,40	50	231.512.500.11	69,90
25	231.512.250.11	28,00	55	231.512.550.11	89,00
26	231.512.260.11	28,30	60	231.512.600.11	106,60

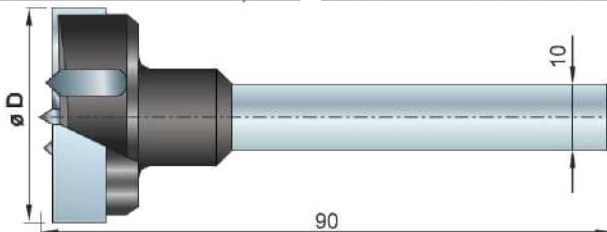

Štandardný HM sukovník, pre široké spektrum použitia. Na požiadanie možnosť výroby aj ľavotočivého prevedenia.



501		VŔTACIA KORUNKA M12		HW
ø D	RH	LH	€	
20	231.501.200.11	231.501.200.12	33,30	
22	231.501.220.11	231.501.220.12	33,20	
24	231.501.240.11	231.501.240.12	34,10	
25	231.501.250.11	231.501.250.12	36,50	
26	231.501.260.11	231.501.260.12	36,90	
30	231.501.300.11	231.501.300.12	39,50	
32	231.501.320.11	231.501.320.12	39,90	
34	231.501.340.11	231.501.340.12	42,20	
35	231.501.350.11	231.501.350.12	40,50	
36	231.501.360.11	231.501.360.12	45,40	
38	231.501.380.11	231.501.380.12	49,20	
40	231.501.400.11	231.501.400.12	50,40	
45	231.501.450.11	231.501.450.12	59,90	
50	231.501.500.11	231.501.500.12	67,50	

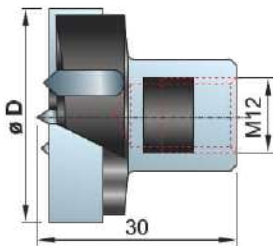

Vymeniteľný HM sukovník. Možnosť osadiť na rôzne druhy unášačov a tým doceliť požadovanú celkovú dĺžku a upínací priemer.

UNÁŠAČE M12		HW
TYP 511 Unášač M12 s valcovou stopkou a ploškou		
ø d	L	Nr RH Nr LH €
10	27	231.511.270.01 231.511.270.02 13,40
10	40	231.511.400.01 231.511.400.02 13,40
10	47	231.511.470.01 231.511.470.02 14,20
TYP 509 Unášač M12 s valcovou stopkou		
ø d	L	Nr RH Nr LH €
13	100	231.509.130.01 231.509.130.02 13,40
16	100	231.509.160.01 231.509.160.02 13,40

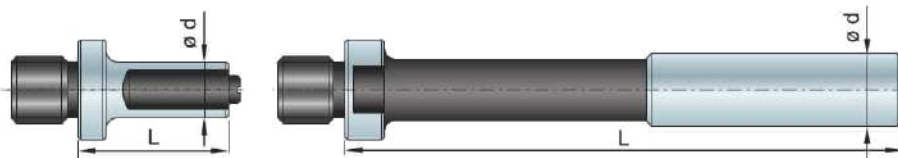



0511		SUKOVNÍK S NASTAVITELNÝM PRIEMEROM		FISCH	SP
$\varnothing D$	$\varnothing d$	L	Nr	€	
22-76	10	170	231F051122-075	85,10	
70-110	13	170	231F051170-110	138,40	

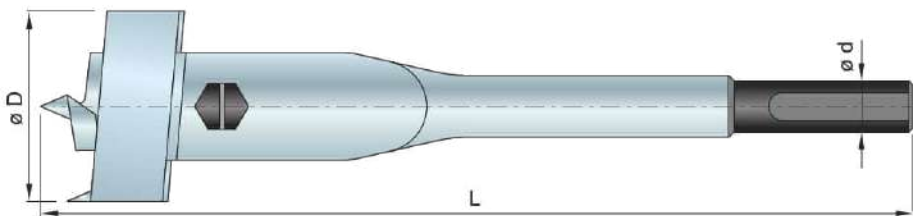

Nastaviteľný sukovník z nástrojovej ocele určený prevažne na masív, okrajovo pre surovú MDF.



R110		SUKOVNÍK S NASTAVITELNÝM PRIEMEROM		HW	
$\varnothing D$	L	Z	$\varnothing d$	Nr	€
30 - 60	90	1+1	10	606R110600R	115,00
60 - 80	100	1+1	12	606R110800R	286,00
30 - 45	nôž			606R110300N	54,00
45 - 60	nôž			606R110450N	56,00
60 - 80	nôž			606R110801N	129,00

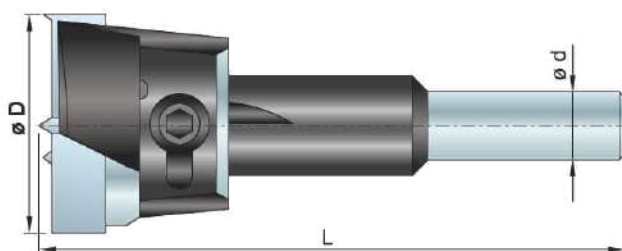

Nastaviteľný HM sukovník. Určený na obrábanie masívu, MDF, LDTD.



0373		ZÁTKOVNÍK HOBBY		FISCH	SP
$\varnothing D$	B	L	$\varnothing d$	Nr	€
8	18	53	10	231F037300800	21,10
10	18	53	10	231F037301000	21,40
12	18	53	10	231F037301200	25,60
15	18	53	10	231F037301500	27,30

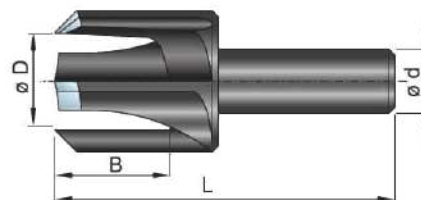

Zátkovník určený na malé priemery vyspravovacích zátk. Ekonomická verzia nástroja.



0360		ZÁTKOVNÍK PROFI		FISCH	SP
$\varnothing D$	B	L	$\varnothing d$	Nr	€
10	80	140	13	231F036001000	53,40
12	80	140	13	231F036001200	56,40
15	80	140	13	231F036001500	57,90
18	80	140	13	231F036001800	69,70
20	80	140	13	231F036002000	69,70
25	80	140	13	231F036002500	73,00
30	80	140	13	231F036003000	75,80
35	100	160	16	231F036003500	88,30
40	100	160	16	231F036004000	101,90
45	100	160	16	231F036004500	114,30
50	100	160	16	231F036005000	131,40

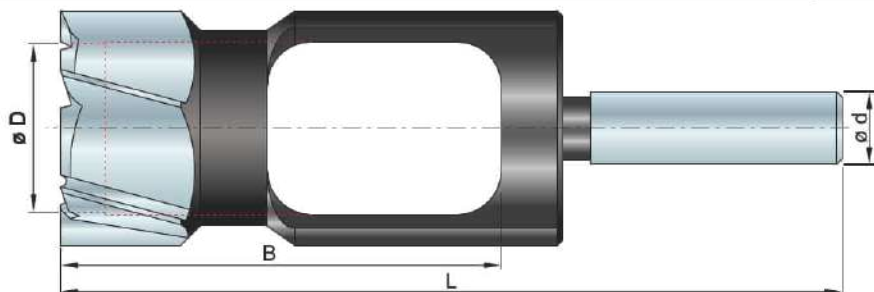

Priemyselný zátkovník určený na výrobu vyspravovacích zátk v dielenských podmienkach. Na vyžiadanie je dostupný aj HSS nástroj pre vyššie zaťaženie.



0600		ZÁHLBNÍK STOPKOVÝ 45°		FISCH	SP
ø D	L	ø d	Nr	€	
10	90	6	231F060001000	10,30	
12	90	6	231F060001200	11,75	
13	90	6	231F060001300	12,00	
16	90	6	231F060001600	12,00	
18	90	6	231F060001800	13,90	
20	90	8	231F060002000	13,90	
25	90	10	231F060002500	22,10	

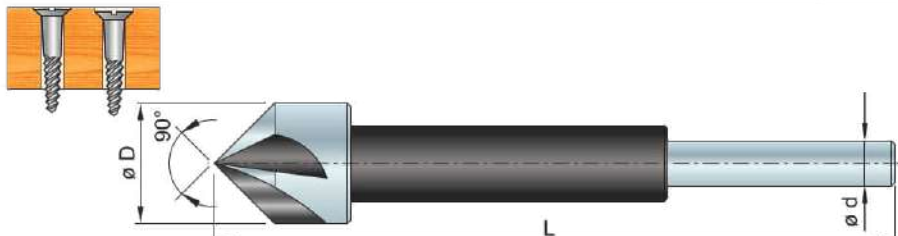

Záhlbník z nástrojovej ocele Z=5, určený pre zahľbovanie a zrážanie hrán otvorov v mäkkých a tvrdých drevinách.



0606		ZÁHLBNÍK STOPKOVÝ 45° EASY		FISCH	HSS
ø D	L	ø d	Nr	€	
10,4	50	6	231F0606010401	16,35	
12,4	56	8	231F0606012401	18,30	
16,5	60	10	231F0606016501	22,90	
20,5	63	10	231F0606020501	32,90	
25	67	10	231F0606025001	39,80	

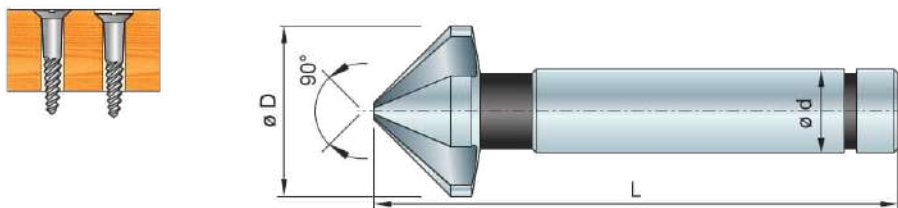

Priemyselný záhlbník pre zahľbovanie a zrážanie hrán otvorov bez otrepov s vysokými požiadavkami na kvalitu. Vhodný aj na neželezné kovy a oceľ.



060XEM		ZÁHLBNÍK STOPKOVÝ 45° EASY - BIT		FISCH	HSS
ø D	L	Nr	€		
10,4	36	231F060XEM104	18,40		
12,4	36	231F060XEM124	19,90		
16,5	40	231F060XEM165	24,30		
20,5	40	231F060XEM205	33,20		

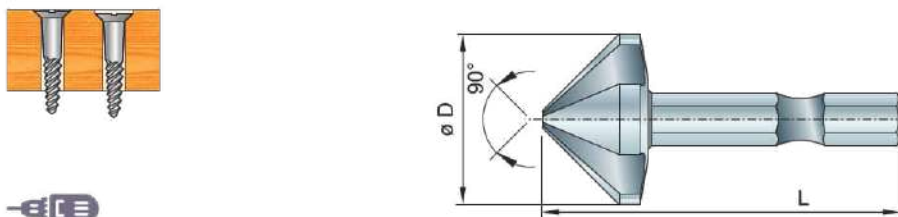

Priemyselný záhlbník pre zahľbovanie a zrážanie hrán otvorov bez otrepov s vysokými požiadavkami na kvalitu. Vhodný aj na neželezné kovy a oceľ.



A199		ZÁHLBNÍK 45° NASTAVITELNÝ		HW	
ø D1	ø D2	B	L	Nr	€
3 - 7	11 - 15	12	32	606A199030R	23,40

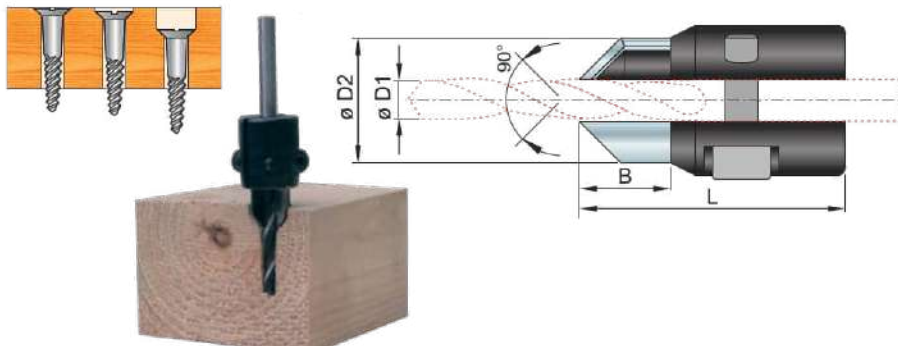

Záhlbník je možné nastrčiť na vrtáky priemeru 3-7mm. Vyhotovenie záhlbníka umožňuje súčasným vrtaním zahľbovať a zapúšťať do hĺbky 12mm.



VRTÁKY NA KONFIRMÁTY - MONTÁŽNICKE

SP, HS, HW



HOBBY - SP

ø D	ø d	D1	D2	L	Nr	€
5	10	2,5	3	68	3288801205	5,00
7	10	2,5	5	68	3288801207	5,80

Zložený vrták na konfirmáty pre občasné použitie. Vložený HSS vrták je možné nastaviť na požadovanú hĺbku. Stupňovitá časť Z=1 je z nástrojovej ocele.

PROFI

Klein
STIEUWI

ø D	ø d	D1	D2	L	Nr	€
8 HS	10	3,5	5	90	606R209035R	26,50
10 HS	10	5	7	100	606R209050R	27,40
11,5 HW	10	8	8,5	100	606R108050R	98,80

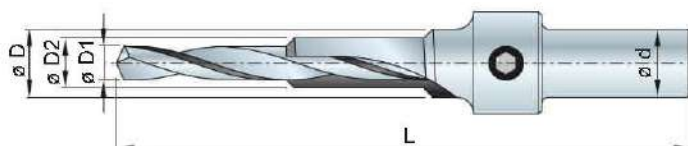
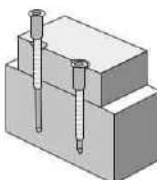

Zložený vrták na konfirmáty kvalitívne a materiálovo odpovedajúci európskym štandardom. Vložený HSS vrták je možné nastaviť na požadovanú hĺbku. Stupňovitá časť Z=2 v prevedení HM. Výrazne vyššia životnosť.

30185
VRTÁK NA DVEROVÉ ZÁVESY

HS



ŠTANDARD

Klein
STIEUWI

ø D1	ø d=ø D	B1	B	L	Nr	€
5,8	7,2	13	69	156	606R208140R	23,80
6,3	7,7	14	75	165	606R208160R	24,90
7,4	8,8	16	81	175	606R208200R	34,70



PREMIUM - so strediacim hrotom

JSO
KOVENOCHEK

ø D1	ø D	B1	B	L	ø d	Nr	€
6,3	7,2	24	64	105	10	23330185407201R	64,80

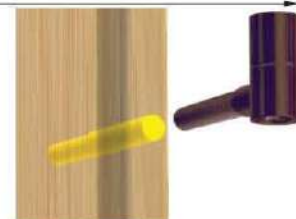
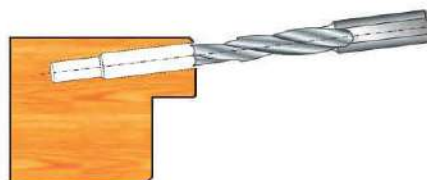
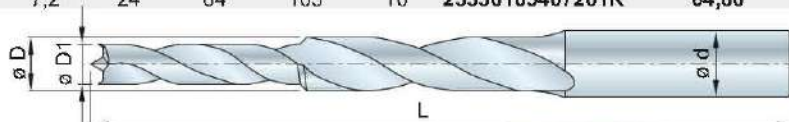

Stupňovité vrtáky pre 3D závesy interiérových dverí a okien.

0190
VRTACIE SETY NA TERASY

FISCH

HS



SET	Nr	€
SET A vrtáky priemerov 4; 4,5; 5 a 6mm, záhlbník, hĺbkový doraz a sada BIT-ov s nadstavcom	231F01900007K	111,00
SET B vrtáky priemerov 4; 4,5; 5 a 6mm, záhlbník, hĺbkový doraz, zátkovnik a sada BIT-ov.	231F01900007K01	113,60
NÁHRADNÉ VRTÁKY	Nr	€
vrták 4	231F01900400022	17,82
vrták 4,5	231F01900450016	20,20
vrták 5	231F01900500046	21,10
vrták 6	231F01900600037	22,80
záhlbník	231F0639Z0401200	25,30

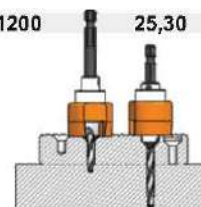

Dva druhy ucelených setov na montáž terasových dosiek. Súčasťou setu 231F01900007K01 je aj zátkovnik na výrobu zátkov pre prípad, ak viditeľnosť hlavičky skrutky nie je žiadanou.

5.19

WOOD-B
priateľ dreva



HĽBKOVÝ DORAZ SAFE FISCH

0973J - pre vrtáky

ø d	ø D	Nr	€
3	25	231F973J50050300	14,00
4	25	231F973J50050400	14,00
5	25	231F973J50050500	14,00
6	25	231F973J50050600	14,00
8	28	231F973J50050800	16,20
10	28	231F973J50051000	16,20
12	31	231F973J50051200	18,60

0973F - pre sukovníky

ø d	ø D*	Nr	€
8	15-21	231F973F0008	34,00
10	22-30	231F973F0010	34,00
12	32-38	231F973F0012	34,00
14	40-50	231F973F0014	34,00

* priemery sukovníkov typ 0317

Vďaka svojej otočnej konštrukcii, a tvarovej dorazovej ploche z plastu umožňuje dobrý odvod triesky a zamedzuje poškodeniu vrtaného materiálu.



NASTAVITELNÝ VYKRUŽOVACÍ VRTÁK FISCH SP

ø D	B	ø d	Nr	€
40-200	30 max.	10	231F973F106SP	158,00

Nastavitelný vykrúžovací vrták pre vrtanie širokého rozsahu priemerov na neprodukčné vrtanie.



VRTÁK DEKORATÍV HW

ø D	L	ø d	Nr	€
80	81	12	301B2641701	205,30

Decoratívny vrták s vymeniteľnými profilovými nožmi, ktoré vyrábame na zákazku.



S250 KORUNKA NA VÝROBU KOLÍKOV HSS

ø D	d	Z	Nr	€
8	21/14 x 1"	4	606S250080R	149,70
8,2	21/14 x 1"	4	606S250082R	149,70
10	21/14 x 1"	4	606S250100R	149,70
10,2	21/14 x 1"	4	606S250102R	149,70
12	21/14 x 1"	4	606S250120R	149,70
12,2	21/14 x 1"	4	606S250122R	149,70

Vrtacia korunka na výrobu hladkých valcových drevených tyčí na špeciálnych strojoch.



102 DLABACÍ VRTÁK S DELIČOM TRIESKY				SP
ø D	L	Nr RH	Nr LH	€
6	105	231.102.060.31	231.102.060.32	21,50
7	110	231.102.070.31	231.102.070.32	25,00
8	115	231.102.080.31	231.102.080.32	22,00
8	130	231.102.081.31	231.102.081.32	27,30
9	120	231.102.090.31	231.102.090.32	25,70
10	125	231.102.100.31	231.102.100.32	22,40
10	140	231.102.101.31	231.102.101.32	28,30
11	130	231.102.110.31	231.102.110.32	26,20
12	135	231.102.120.31	231.102.120.32	22,80
12	150	231.102.121.31	231.102.121.32	29,00
13	140	231.102.130.31	231.102.130.32	27,50
14	145	231.102.140.31	231.102.140.32	23,90
14	160	231.102.141.31	231.102.141.32	29,80
15	150	231.102.150.31	231.102.150.32	29,00
16	155	231.102.160.31	231.102.160.32	25,40
16	170	231.102.161.31	231.102.161.32	31,20
18	165	231.102.180.31	231.102.180.32	34,80
20	175	231.102.200.31	231.102.200.32	38,70
22	180	231.102.220.31	231.102.220.32	53,80
24	180	231.102.240.31	231.102.240.32	60,80



Štandardný dlabací vrták z nástrojovej ocele a deličom triesky pre vrtacie dlabáčky s ruč. posuvom.



0212 ŠPIRÁLOVÝ DLABACÍ VRTÁK S DELIČOM TRIESKY							SP
0212				HSS			
ø D	B	L	ø d	Nr RH	Nr LH	€	
6	40	110	6	231F02120600R	231F02120600L	11,80	
8	40	110	8	231F02120800R	231F02120800L	13,00	
10	45	125	10	231F02121000R	231F02121000L	13,70	
12	45	125	12	231F02121200R	231F02121200L	17,90	
14	50	135	13	231F02121400R	231F02121400L	22,30	
16	50	135	13	231F02121600R	231F02121600L	25,80	

0240							SP
ø D	B	L	ø d	Nr RH	Nr LH	€	
6	36	120	16	231F02400600RA	231F02400600LA	24,20	
8	40	130	16	231F02400800RA	231F02400800LA	24,20	
10	45	140	16	231F02401000RA	231F02401000LA	24,20	
12	50	150	16	231F02401200RA	231F02401200LA	24,20	
14	56	160	16	231F02401400RA	231F02401400LA	27,50	
16	63	170	16	231F02401600RA	231F02401600LA	28,80	
18	67	180	16	231F02401800RA	231F02401800LA	29,40	
20	71	185	16	231F02402000RA	231F02402000LA	40,00	
22	75	190	16	231F02402200RA	231F02402200LA	53,20	

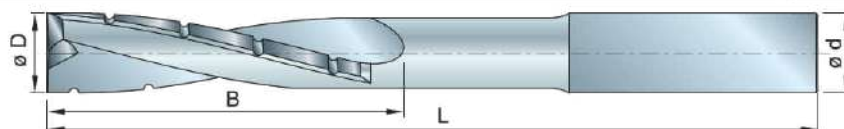

Prémiový špirálový dlabací vrták s deličom triesky pre vrtacie dlabáčky s ručným posuvom. Vďaka špirálovej konštrukcii má vrták vynikajúci odvod triesky a plynulejší chod. Nie je vhodný pre dlabáčky s vŕtami v pojazdoch.



0260 DLABACÍ VRTÁK PENDEL Z=2						HS
ø D	B	L	ø d	Nr	€	
8	49	95	13	231F026008008	24,92	
10	60	105	13	231F026010008	25,77	
14	80	125	13	231F026014008	30,36	

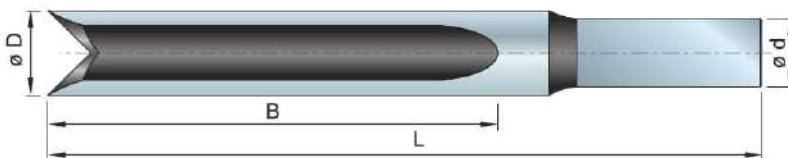

Dlabací vrták určený pre oscilačné dlabáčky.



DNDB REŤAZOVÉ DLABACIE SÚPRAVY SP

B	reťaz			lišta			pastorok		
	Nr	€		Nr	€		Nr	€	
6	301009	209,08		301001	268,52		301018	40,00	
8	301010	213,64		301002	272,68		301019	40,00	
10	301011	219,95		301003	278,52		301020	37,30	
12	301012	231,81		301004	285,19		301021	37,30	
14	301013	236,36		301004	285,19		301021	37,30	
16	301014	252,67		301004	285,19		301021	37,30	
18	301015	340,90		301005	296,15		301022	44,20	
20	301016	354,54		301005	296,15		301022	44,20	
22	301017	347,37		301006	296,15		301023	44,20	

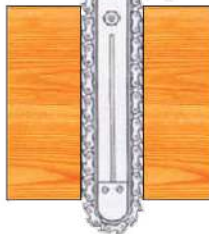

Na zákazku dodávame široký rozmerový a kvalitatívny sortiment dlabacích reťazí pre rôzne typy strojov. Žiadajte katalogový list.



VRTÁKY DOMINO Klein SYSTEM HW

D=M6X0,75 (DF500)

ø D=d	B	L	Nr	€
4	11	38	606F160040R	29,30
5	20	49	606F160050R	26,10
6	28	49	606F160060R	26,70
8	28	49	606F160080R	29,00
10	28	49	606F160100R	30,90

D=M8X1 (DF700)

ø D=d	B	L	Nr	€
8	50	90	606F161080R	32,00
10	70	90	606F161100R	34,20
12	70	90	606F161120R	42,80
14	70	90	606F161140R	55,20

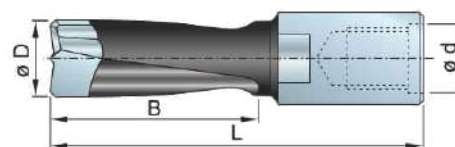

Dlabacie oscilačné vrťáky určené do elektrického ručného náradia pre zhotovovanie konštrukčných spojov "DOMINO".



DLABACIE ŠTVORCOVÉ VÝSEKOVÉ VRTÁKY FISCH SP

Kompletný set

ø D	B	L	ø d	ø dv	Nr	€
6	48	155	15,88	4,4	231F03820600108	52,00
8	48	185	15,88	5,8	231F03820800108	59,90
16	140	310	20,64	10	231F03821600310	128,20

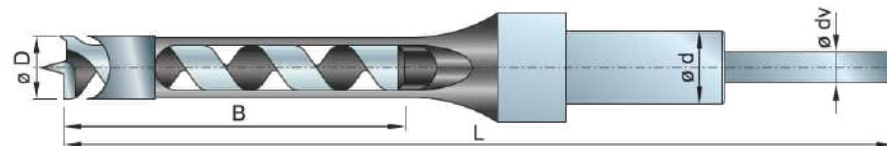

Brúsne sety

	Nr	€
Brúsny SET na dláta	360MCS01	31,25
Dláta pre štvorcové otvory 4-dielny set	360144010	33,00



Nástroje určené na zhotovovanie ostrohranných dlabov na špeciálnych vŕtaco-výsekových dlabáčkach, alebo stojanových vŕtačkách osadených prípravkom pre tento typ nástroja.



UNI HM



BIMETAL



CLEANCUT



PRO-FIT

HW

Profesionálny systém vykrúžovacích vrtákov s jednoduchou a účinnou aretáciou vykrúžovacieho vrtáka na vodiacom vrtáku. Vďaka tomu je možné jednoduché a rýchle odstránenie odpadu po vrtaní z vykrúžovacieho vrtáka.

UNI HM			BIMETAL		CLEANCUT	
ø D	Nr	€	Nr	€	Nr	€
20	231F97109081020	23,70	231F97109051020	20,00		
22	231F97109081022	23,70	231F97109051022	20,00		
24	231F97109081024	23,70	231F97109051024	20,60		
27	231F97109081027	24,70	231F97109051027	20,70		
30	231F97109081030	24,70	231F97109051030	20,70		
32	231F97109081032	24,70	231F97109051032	21,30		
35	231F97109081035	26,30	231F97109051035	22,30		
38	231F97109081038	26,30	231F97109051038	22,30		
40	231F97109081040	26,50	231F97109051040	23,50		
44	231F97109081044	30,70	231F97109051044	26,10		
48	231F97109081048	30,70	231F97109051048	26,11		
51	231F97109081051	31,20	231F97109051051	26,10	231F97104111051	26,34
54	231F97109081054	35,43	231F97109051054	27,50		
57	231F97109081057	35,80	231F97109051057	29,10	231F97104111057	26,50
60	231F97109081060	35,60	231F97109051060	30,30	231F97104111060	27,00
65	231F97109081065	38,60	231F97109051065	31,50		
68	231F97109081068	38,80	231F97109051068	32,20	231F97104111068	28,30
70	231F97109081070	38,80	231F97109051070	32,90		
76	231F97109081076	42,00	231F97109051076	34,50	231F97104111076	30,20
83	231F97109081083	42,70	231F97109051083	35,10	231F97104111083	31,40
86	231F97109081086	48,00	231F97109051086	35,10	231F97104111086	32,70
92	231F97109081092	48,00	231F97109051092	39,80	231F97104111092	33,40
98	231F97109081098	54,20	231F97109051098	43,80		
105	231F97109081105	59,70	231F97109051105	49,40		
114	231F97109081114	88,50	231F97109051114	66,40		
127	231F97109081127	105,30	231F97109051127	71,90		
140	231F97109081140	125,50	231F97109051140	81,85		
152	231F97109081152	132,90	231F97109051152	90,70		
160	231F97109081160	151,70	231F97109051160	129,30		
168	231F97109081168	161,20	231F97109051168	134,20		
177	231F97109081177	177,50	231F97109051177	139,40		
185	231F97109081185	215,00	231F97109051185	151,10		
200	231F97109081200	277,20	231F97109051200	156,20		
210	231F97109081210	277,20	231F97109051210	164,00		

UNI - Tvrdokovové vykrúžovacie vrtáky pre všestranné použitie pre otvory v masive, materiáloch na báze dreva, plastoch, pórobetóne, tehliach a keramických obkladových materiáloch.

Dlhá životnosť nástroja aj v abrazívnych materiáloch. Maximálna hrúbka materiálu je 52mm.



BIMETAL - Bimetalové vykrúžovacie vrtáky určené pre oceľ, nerezovú oceľ a nežeľzné kovy do hrúbky steny 3mm.

Vďaka špeciálnemu materiálu s kobaltovou legúrou majú vrtáky dlhú životnosť.



CLEANCUT - HSS vykrúžovacie vrtáky so špeciálnou geometriou určenou pre sadrokartónové dosky a izolačné materiály.

Výnimočne hladký a čistý otvor aj z výstupnej strany. Maximálna hrúbka materiálu je 52mm.

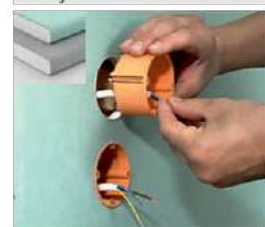
VODIACI VRTÁK HSS -
PRE VYKRÚŽOVACIE VRTÁKY UNI A CLEAN CUT

HW

ø D vykrúž. vrtáka	dĺžka	stopka	Nr	€
16-32	184	HEX 8	231F971DDH1MP	15,30
16-32	320	HEX 8	231F971DDH1XLMP	26,50
32-320	186	HEX 10	231F971DDH2MP	20,50
32-320	320	HEX 10	231F971DDH2XLMP	30,25

VODIACI VRTÁK HSS-C -
PRE VYKRÚŽOVACIE VRTÁKY BIMETAL

HW

ø D vykrúž. vrtáka	dĺžka	stopka	Nr	€
14-30	155	HEX 8	231F971DDH1	15,30
32-210	158	HEX 10	231F971DDH2	20,50



UNI HM LONG - pracovná dĺžka vrtáka 152mm

HW

ø D	Nr	€
32	231F97109281032	63,21
51	231F97109281051	72,68
60	231F97109281060	81,69
68	231F97109281068	96,41
76	231F97109281076	103,34
102	231F97109281102	122,33
105	231F97109281105	122,33
111	231F97109281111	136,82
152	231F97109281152	211,23





VODIACE VRTÁKY PRE PRO-FIT HM UNI LONG

HSS - predĺžený				
pre vrtáky ø D	ø d x L	stopka	Nr	€
32-320	10x235	HEX 10	231F0084100235	12,99
32-320	12x235	HEX 10	231F0084120235	14,30
HM do betónu - predĺžený				
pre vrtáky ø D	ø d x L	stopka	Nr	€
32-320	10x200	HEX 10	231F97109287141	19,17
32-320	12x200	HEX 10	231F97109287241	19,16
Vodiaci čas				
pre vrtáky ø D	ø d x L	stopka	Nr	€
32-320	10x330	HEX 10	231F971DDC2LHD	34,64
32-320	12x300	HEX 10	231F971DDC3LHD	36,81

Pilotné vrtáky slúžia na vyvrtanie vodiaceho otvoru pre UNI HM Long. S vrtákom UNI HM long osadeným vodiacim časom sa následne vyvrtá požadovaný otvor. Pri väčších hrúbkach materiálov je možné vďaka vodiacemu času vrtanie z oboch strán.



VYKRUŽOVACIE PÍLKY - BIMETALOVÉ HSS

ø D	Nr	€	ø D	Nr	€
22	51317011	3,17	60	51325688	6,83
24	51317027	2,92	65	51324882	6,75
25	51317033	3,17	68	51317108	7,25
29	51317267	3,92	70	51325694	7,83
32	51317049	4,08	76	51317114	8,50
35	51317055	4,25	83	51317120	8,92
38	51317061	4,92	92	51317136	10,25
40	51317273	5,17	95	51352716	12,38
44	51317077	5,17	105	51317142	11,00
51	51317083	6,00	127	51317158	13,75
54	51324876	6,00	152	51317164	16,00
57	51317099	6,17			

ADAPTER šesťhranné upínanie		
ø D pilky	Nr	€
16-29	51317170	3,17
32-152	51317186	5,92

ADAPTER SDS plus upínanie		
ø D pilky	Nr	€
16-29	51317603	3,50
32-152	51317619	7,42
vrták centrovací 6x75 51317192 1,50		



Veľmi univerzálne použitie. Zvlášť vysoká prevádzková životnosť, agresívna geometria. Možnosť upínania cez SDS plus alebo šesť-hran.



VYKRUŽOVACIE PÍLKY - TVRDOKOVOVÉ HW

ø D	Nr	€	ø D	Nr	€
25	5034932464921	16,23	70	5034932464930	20,86
30	5034932464922	21,58	76	5034932464931	24,34
35	5034932464923	17,39	82	5034932464932	26,67
44	5034932464924	17,61	92	5034932464933	29,52
51	5034932464925	18,07	102	5034932464934	38,33
54	5034932464926	18,55	108	5034932464935	34,07
57	5034932464927	19,00	117	5034932464936	37,55
65	5034932464928	19,70	133	5034932464937	49,92
68	5034932464929	20,43	159	5034932464938	47,52

PRÍSLUŠENSTVO

ø D pilky	Nr	€
vrták pilotný	5034932464940	3,77
unášač 32 - 210 mm	50349567250	13,17
unášač 14 - 30 mm	50349567010	4,57



Vhodné pre montáže kuchýň. Možnosť vrtania širokej škály materiálov. Nevhodné pre betón, žulu.



VYKRUŽOVACIE PÍLKY - S PRUŽINOU HSS+8%CoBalt

ø D	Nr	€
19	50349569805	14,80
22	50349569810	14,34
25	50349569815	14,57
29	50349569820	15,02
32	50349569825	15,27
35	50349569830	15,50
38	50349569835	15,73



Určené pre vrtanie tenkých plechov (2mm), hliníka a nerezových plechov (1,5mm). Upínanie pre priame upevnenie do uťahovačky.



VRTÁKY NA SKLO

HW



ø D	Nr	€
3	513CZVS4B0300	5,58
4	513CZVS4B0400	5,33
5	513CZVS4B0500	6,00
6	513CZVS4B0600	7,08
8	513CZVS4B0800	7,42
10	513CZVS4B1000	8,75
12	513CZVS4B1200	9,58
14	513CZVS4B1400	10,92
16	513CZVS4B1600	13,17



Vrtáky na sklo určené na vrtanie za sucha.

0652
STUPŇOVITÉ VRTÁKY NA PLECH

FISCH HSS



ø D	L	ø d	Nr	€
4, 6, 8, 10, 12, 14, 16, 18, 20	75	8	231F065204020	65,80
6, 8, 10, 12, 14, 16, 18, 20, 22, 24, 26, 28, 30	92	9,6	231F065204030	94,10

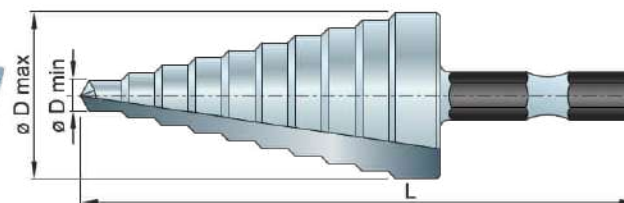
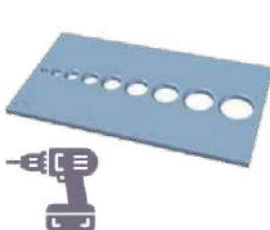

Vrtáky na vrtanie otvorov v tenkostenných plechových obrobkoch. Veľkou výhodou je, že v prechodoch jednotlivých priemerov je 45° skosenie, ktoré otvor zároveň očistí od otrepov.

88619
ZIRKÓNOVÉ VRTÁKY DO KOVU

FISCH HSS



ø D=d	pre závit	B	L	Nr	€
3		33	61	231F88619030061	4,60
3,3	(M4)	36	65	231F88619033065	5,50
4		43	75	231F88619040075	5,90
4,2	(M5)	43	75	231F88619042075	6,20
5	(M6)	52	86	231F88619050086	6,70
6		57	93	231F88619060093	9,00
6,8	(M8)	69	109	231F88619068109	10,80
8		75	117	231F88619080117	12,70
8,5	(M10)	75	117	231F88619085117	13,20
10		87	133	231F88619100133	19,20
10,2	(M12)	87	133	231F88619102133	27,20
12		101	151	231F88619120151	38,30

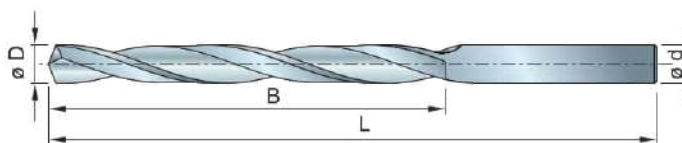

HSS vrtáky so špeciálnym zirkónovým povlakom, ktorý významne zlepšuje rezné vlastnosti a predlžuje životnosť. Určené pre vrtanie ocele, liatiny a neželezných kovov.

88114
MULTI VRTÁKY NA ŠIROKOSPEKTRÁLNE POUŽITIE

FISCH HM



ø D = ø d	B	L	Nr	€
4	35	75	231F88114040075	6,00
5	45	85	231F88114050085	6,30
6	60	100	231F88114060100	7,30
6	210	250	231F88114060250	17,00
8	80	120	231F88114080120	8,00
8	210	250	231F88114080250	17,50
10	80	120	231F88114100120	8,48
10	210	300	231F88114100300	16,80
12	110	150	231F88114120150	10,45
12	210	300	231F88114120300	19,01
14	110	150	231F88114140150	12,95

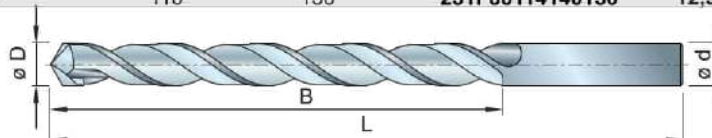

Vrtáky s HM reznou korunkou brúsenou na čele, chrbte a obvode. Obzvlášť vhodné na vrtanie otvorov pre hmoždinky bez príklepu cez obkladačky/tehla; obkladačky/betón. Komplexne brúsená geometria umožňuje vrtanie širokého spektra materiálov cez drevo, preglejku, neželezné kovy, oceľ až po stavebné materiály.

OBSAH



CNC FRÉZY



eshop.woodb.sk



STROJE

NÁSTROJE

NÁRADIE

KOVANIE

CHÉMIA

SPOJOVACÍ MATERIAL

DIELŇA

DOM-ZÁHRADA

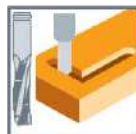
*Špirálové monolitické frézy*

6.1

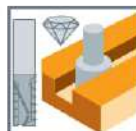
*Dverové frézy**Diamantové frézy*

6.15

*Frézovacie CNC hlavy*

7.7

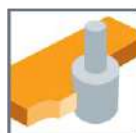
*Obvodové, plošné frézy*

6.8

*Prísavky*

7.10

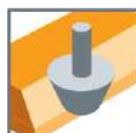
*Uhlové frézy*

6.8

*Príslušenstvo*

7.4

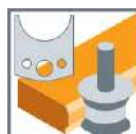
*Univerzálne stopkové hlavy*

6.10

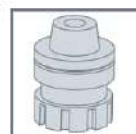
*Upínače a klieštiny*

7.1

*Gravírovacie frézy*

6.11

*Hobby CNC frézy*

8.1

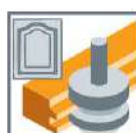
*Dvierkové frézy*

6.12

Organizujeme
kurzy CNC
obrábania

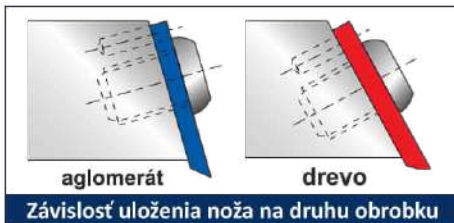

Závislosť uloženia noža na druhu obrobku

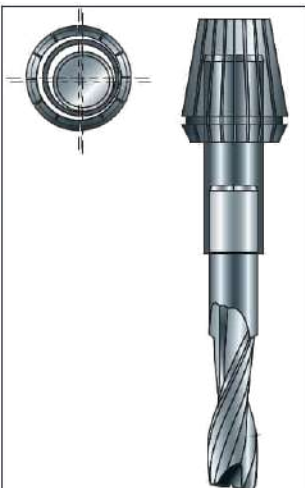

Centricita upínania

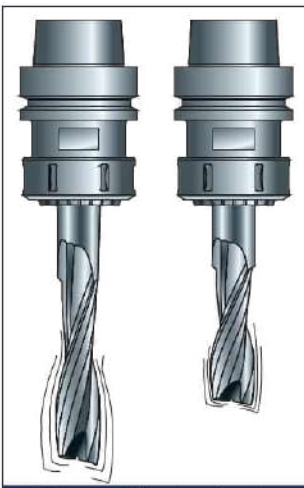

Vplyv vyloženia nástroja na jeho presnosť

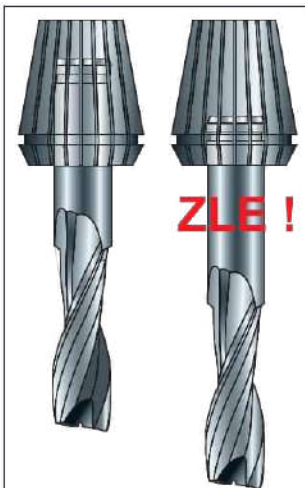

Spôsob upnutia nástroja

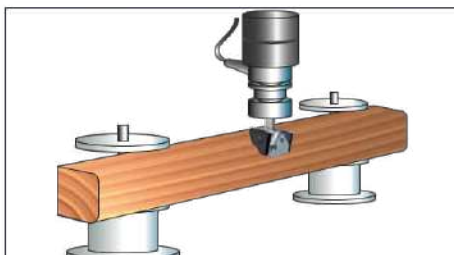

Tuhosť upnutia obrobku

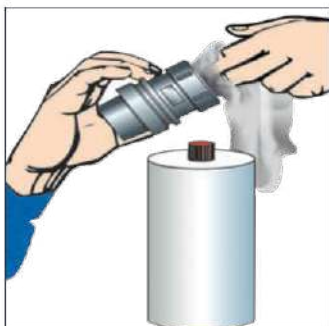

Čistota upínača



Fixovanie uťahovacej matice



Spôsoby „kapsovania“

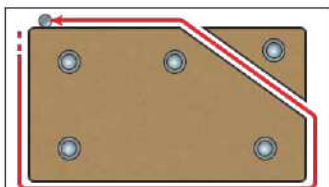
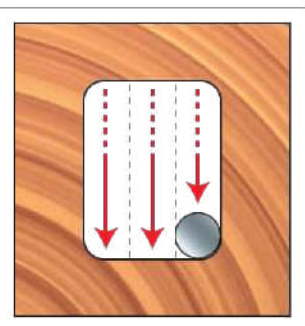

Stratégia obrábania



Uťahovací moment pre ER40

Priemer stopky S (mm)	Min. upínacia dĺžka λ (mm)
$S \geq 10$	$\lambda \geq 20$
$10 < S < 25$	$\lambda = S \times 2$
$S \geq 25$	$\lambda = S \times 1,8$

Závislosť upínacej dĺžky na priemere stopky

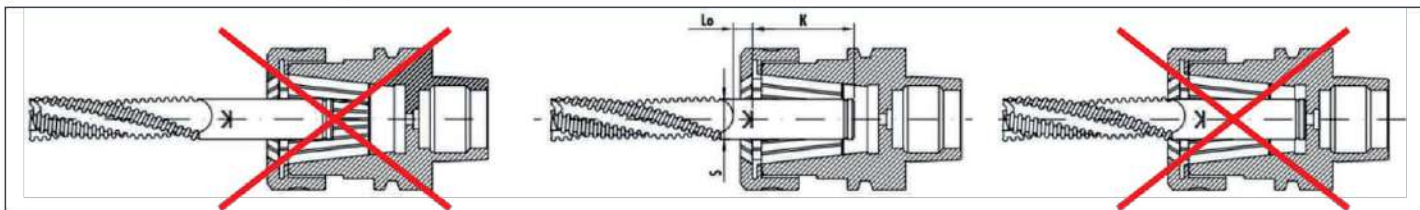

Uloženie nástroja v klieštine



Druhy obrábaných materiálov

ŠPIRÁLOVÉ FRÉZY DOKONČOVACIE

HW

Z1 jednobřitá

Ø D=d	B	L	Nr Pozitiv	Nr Negativ	€
3	12	50	231.91P.030.11	231.91N.030.11	14,20
4	12	50	231.91P.040.11	231.91N.040.11	14,90
5	17	50	231.91P.050.11	231.91N.050.11	16,80
6	17	60	231.91P.060.11	231.91N.060.11	19,80
6	27	60	231.91P.061.11	231.91N.061.11	21,40
8	22	80	231.91P.080.11	231.91N.080.11	25,20
8	32	80	231.91P.081.11	231.91N.081.11	27,90
10	32	80	231.91P.100.11	231.91N.100.11	39,00
10	42	100	231.91P.101.11	231.91N.101.11	62,10
12	32	80	231.91P.120.11	231.91N.120.11	73,60
12	42	100	231.91P.121.11	231.91N.121.11	58,60

Z2 dvojřitá

Ø D=d	B	L	Nr Pozitiv	Nr Negativ	€
3	12	50	231.92P.030.11	231.92N.030.11	14,20
4	12	50	231.92P.040.11	231.92N.040.11	14,90
5	17	50	231.92P.050.11	231.92N.050.11	16,80
6	17	60	231.92P.060.11	231.92N.060.11	20,40
6	27	60	231.92P.061.11	231.92N.061.11	21,20
8	22	80	231.92P.080.11	231.92N.080.11	28,40
8	32	80	231.92P.081.11	231.92N.081.11	28,20
10	32	80	231.92P.100.11	231.92N.100.11	39,50
10	42	100	231.92P.101.11	231.92N.101.11	47,30
12	32	80	231.92P.120.11	231.92N.120.11	53,60
12	42	100	231.92P.121.11	231.92N.121.11	59,90
12	55	100	231.92P.122.11	231.92N.122.11	69,90
14	45	100	231.92P.140.11	231.92N.140.11	109,20
14	55	100	231.92P.141.11	231.92N.141.11	95,20
16	45	100	231.92P.160.11	231.92N.160.11	99,90
16	55	100	231.92P.161.11	231.92N.161.11	108,40
16	72	120	231.92P.162.11	231.92N.162.11	126,90
18	55	100	231.92P.180.11	231.92N.180.11	139,20
18	72	120	231.92P.181.11	231.92N.181.11	238,70
20	55	100	231.92P.200.11	231.92N.200.11	155,20
20	72	120	231.92P.201.11	231.92N.201.11	179,80
20	102	150	231.92P.202.11	231.92N.202.11	324,80

Z3 trojřitá

Ø D=d	B	L	Nr Pozitiv	Nr Negativ	€
6	35	80	231.93P.061.11	231.93N.061.11	41,76
8	22	80	231.93P.080.11	231.93N.080.11	33,80
8	35	80	231.93P.081.11	231.93N.081.11	34,90
10	35	80	231.93P.100.11	231.93N.100.11	41,86
10	45	100	231.93P.101.11	231.93N.101.11	50,60
12	35	80	231.93P.120.11	231.93N.120.11	57,40
12	45	100	231.93P.121.11	231.93N.121.11	66,80
12	55	100	231.93P.122.11	231.93N.122.11	118,90
14	45	100	231.93P.140.11	231.93N.140.11	89,90
14	55	100	231.93P.141.11	231.93N.141.11	95,20
16	45	100	231.93P.160.11	231.93N.160.11	107,00
16	55	100	231.93P.161.11	231.93N.161.11	111,60
16	72	120	231.93P.162.11	231.93N.162.11	199,80
18	55	100	231.93P.180.11	231.93N.180.11	141,50
18	72	120	231.93P.181.11	231.93N.181.11	259,50
20	55	100	231.93P.200.11	231.93N.200.11	159,70
20	72	120	231.93P.201.11	231.93N.201.11	184,50
20	102	150	231.93P.202.11	231.93N.202.11	369,00
25	102	150	231.93P.250.11	231.93N.250.11	477,90
25	125	175	231.93P.251.11	231.93N.251.11	480,00

Z3 trojřitá povlakovaná DIA

Ø D=d	B	L	Nr Pozitiv	Nr Negativ	€
12	45	100	231.93P.121.11E	231.93N.121.11E	66,34
12	55	100	231.93P.122.11E	231.93N.122.11E	66,34
16	45	100	231.93P.160.11E	231.93N.160.11E	116,20
16	55	100	231.93P.161.11E	231.93N.161.11E	116,20

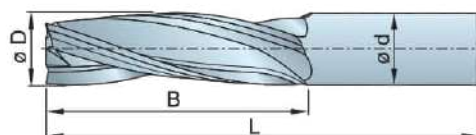

POZITIV

NEGATIV

odvod tresky nahor

dobrá hrana

✓

✓

dobrá hrana

odvod tresky nadol

✓

✓

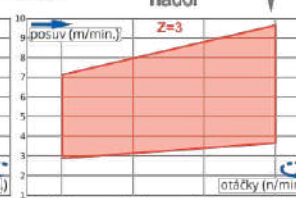
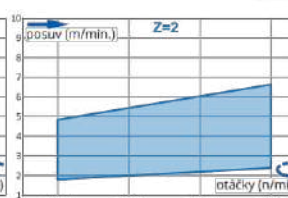
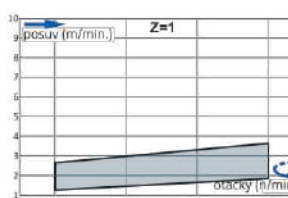

Dokončovacie tvrdokovové špirálové frézy určené hlavne na opracovanie masív. V špeciálnych prípadoch použiteľné aj na plasty a hliník. Pre abrazívne druhy materiálov – DTD, OSB odporúčame použiť povlakované nástroje. Ľavotočivé prevedenie vyrábame na objednávku, rovnako ako zákazkové medziodmery.



ŠPIRÁLOVÉ FRÉZY S DELIČOM TRIESKY - dokončovacie HW

Ø D=d	B	L	Z	Nr Pozitív	€
8	40	80	3	231.93D.080.11	55,70
10	50	100	3	231.93D.100.11	72,20
12	55	100	4	231.93D.120.11	90,40
14	60	110	4	231.93D.140.11	114,60
16	65	110	4	231.93D.160.11	132,70
20	90	120	4	231.93D.200.11	203,50

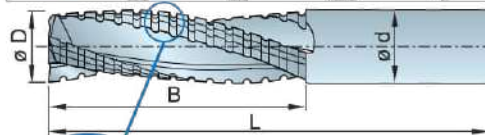

Delič triesky umožňuje väčšiu hodnotu odberu materiálu oproti klasickým dokončovacím frézam, pri zachovaní hladkého frézovaného povrchu. Významne sa eliminuje vyštiepavanie pri obrábaní priečného dreva. Vhodné na obrábanie dreva, materiálov na báze dreva. Určené pre posuvové rýchlosti v rozmedzí 4-12 m/min.



ŠPIRÁLOVÉ FRÉZY S LAMAČOM TRIESKY - hrubovacie HW

Z2 dvojbrité

Ø D=d	B	L	Nr Pozitív	Nr Negatív	€
6	30	70	231.94P.060.11	231.94N.060.11	42,29
8	35	80	231.94P.080.11	231.94N.080.11	54,90
10	35	80	231.94P.100.11	231.94N.100.11	64,90
12	35	80	231.94P.120.11	231.94N.120.11	84,50
12	45	90	231.94P.121.11	231.94N.121.11	99,80

Z3 trojbrité

Ø D=d	B	L	Nr Pozitív	Nr Negatív	€
6	30	70	231.95P.060.11	231.95N.060.11	35,10
8	22	80	231.95P.080.11	231.95N.080.11	37,80
8	35	80	231.95P.081.11	231.95N.081.11	39,60
10	35	80	231.95P.100.11	231.95N.100.11	48,00
10	45	100	231.95P.101.11	231.95N.101.11	55,80
12	35	80	231.95P.120.11	231.95N.120.11	63,40
12	45	100	231.95P.121.11	231.95N.121.11	71,10
12	55	100	231.95P.122.11	231.95N.122.11	82,80
14	45	100	231.95P.140.11	231.95N.140.11	98,60
14	55	100	231.95P.141.11	231.95N.141.11	101,70
16	45	100	231.95P.160.11	231.95N.160.11	115,60
16	55	100	231.95P.161.11	231.95N.161.11	122,00
16	72	120	231.95P.162.11	231.95N.162.11	140,40
18	55	100	231.95P.180.11	231.95N.180.11	146,70
20	55	100	231.95P.200.11	231.95N.200.11	165,60
20	72	120	231.95P.201.11	231.95N.201.11	194,40
20	102	150	231.95P.202.11	231.95N.202.11	374,22
25	102	155	231.95P.250.11	231.95N.250.11	334,00
25	125	175	231.95P.251.11	231.95N.251.11	409,50

Z3 povlakovaná DIA

Ø D=d	B	L	Nr Pozitív	Nr Negatív	€
10	35	80	231.95P.100.11E	231.95N.100.11E	57,70
12	35	80	231.95P.120.11E	231.95N.120.11E	72,10
12	45	100	231.95P.121.11E	231.95N.121.11E	74,00
12	55	100	231.95P.122.11E	231.95N.122.11E	71,60
14	45	100	231.95P.140.11E	231.95N.140.11E	117,20
14	55	100	231.95P.141.11E	231.95N.141.11E	123,50
16	45	100	231.95P.160.11E	231.95N.160.11E	134,20
16	55	100	231.95P.161.11E	231.95N.161.11E	140,40

POZITIV odvod triesky nahor

NEGATÍV odvod triesky nadol

dobrá hrana

dobrá hrana

Hrubovacie tvrdokovové špirálové frézy určené na obrábanie masívu a aglomerovaných materiálov. Pre abrazívne druhy materiálov – DTD, OSB, odporúčame použiť povlakované nástroje s vyššou životnosťou. Lavotčivé prevedenie vyrábame na objednávku, rovnako ako zákazkové medziorozmery.





ŠPIRÁLOVÉ FRÉZY DOKONČOVACIE					HW
POZITÝVNO NEGATÝVNE					
$\varnothing D=d$	B	L	Z	Nr	€
8	22	80	2+2	606T156080R	36,00
8	32	80	2+2	606T156081R	39,00
10	32	80	2+2	606T156100R	48,20
10	42	10	2+2	606T156101R	81,51
12	42	10	2+2	606T156120R	67,70
12	52	110	2+2	606T156121R	79,80
16	42	100	2+2	606T156160R	121,50
16	52	110	2+2	606T156161R	126,20

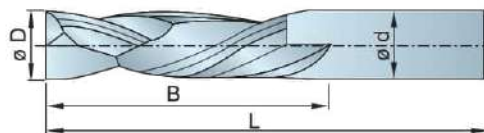

Vhodné na CNC obrábanie dreva a drevných materiálov. Horná aj spodná plocha obrobku bez otrepov. Určené pre stredné posuvové rýchlosti v rozmedzí 5,5-12,5 m/min.



ŠPIRÁLOVÉ FRÉZY NA HLINÍK A PLASTY					HW
Z1 pozitív					Z1 negatív
$\varnothing D$	B	L	$\varnothing d$	Nr Pozitív	€
3	12	60	6	606U111030R	29,80
4	12	60	6	606U111040R	29,80
5	16	60	6	606U111050R	30,80
6	16	60	6	606U111060R	31,70
8	18	60	8	606U111080R	35,10
8	35	80	8	606U111081R	54,90
10	22	70	10	606U111100R	57,50
12	24	70	12	606U111120R	70,65

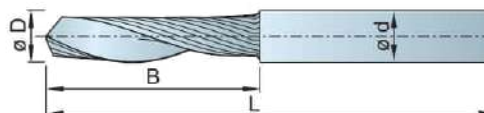

Nástroj s leštenou čelnou plochou eliminuje nalepovanie obrábaného materiálu na nástroj, zefektívňuje odvod triesky. Určené pre hliník, sklotextil, akrylátové materiály, PVC a mäkké plasty aALUCOBOND.



ŠPIRÁLOVÉ FRÉZY TECHNICKÉ					HWC
$\varnothing D=d$	B	L	Nr	€	
3	12	38	606U130030RKD	32,90	
4	15	40	606U130040RKD	38,90	
5	18	50	606U130050RKD	45,50	
6	22	55	606U130060RKD	53,10	
8	30	70	606U130080RKD	67,20	
10	30	72	606U130100RKD	88,70	
12	30	73	606U130120RKD	119,90	

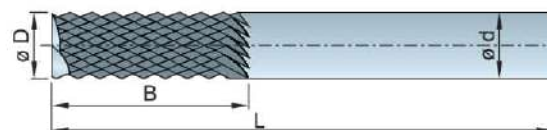

Monolitické technické frézy s krížovým výbrusom určené pre CNC frézovačky. Pre zvýšenie životnosti je nástroj DIA povlakovaný. Určené pre obrábanie sklotextilných materiálov, karbonových prvkov, guma a plastov.



ZÁKAZKOVÉ ŠPIRÁLOVÉ FRÉZY					HW

Na zákazku vyrábame tvrdokovové frézy podľa špecifických rozmerov a tvaru. Nástroje rovnako navrhujeme a konštruujeme podľa špeciálnej požiadavky na spracovanie rôznych druhov obrábaných materiálov a typu použitej technológie obrábania.



ŠPIRÁLOVÉ FRÉZY GULOVÉ Z2				HW		
ø D=d	R	B	L	Nr	€	
3	1,5	12	50	606T175030R	25,30	
4	2	12	50	606T175040R	26,80	
6	3	22	60	606T175060R	37,20	
8	4	22	80	606T175080R	49,60	
10	5	35	80	606T175100R	67,00	
12	6	35	80	606T175120R	89,00	
16	8	55	100	606T175160R	166,00	
20	10	55	110	606T175200R	247,00	

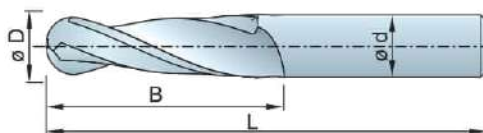

Tvrdokovové špirálové frézy s pozitívnu skrutkovicou na dokončovanie 3D plôch plytších reliéfov. Vhodné na obrábanie dreva, materiálov na báze dreva. Určené pre posuvové rýchlosti v rozmedzí 3-8,4m/min.



ŠPIRÁLOVÉ FRÉZY KOPÍROVACIE KUŽELOVÉ, Z=3 HW						
ø D	R	B	L	ø d	Nr	€
0,8	0,4	25	70	6	606T173009R	52,00
1,6	0,8	25	70	6	606T173017R	49,50
1,6	0,8	25	80	8	606T173018R	66,30
3,17	1,59	30	70	6	606T173033R	56,50
3,17	1,59	50	90	8	606T173034R	99,90

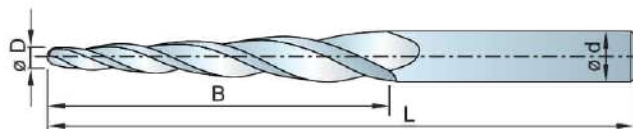

Tvrdokovové kuželové špirálové frézy s rohovým rádiom a pozitívnu skrutkovicou na frézovanie 3D plôch riadkovaním. Hodnota bočného prisuvu v rozmedzí 0,1 až 0,3mm. Vhodné na obrábanie dreva, materiálov na báze dreva.



ŠPIRÁLOVÉ FRÉZY MODELÁRSKE				HW		
Z3 VALCOVÉ DOKONČOVACIE					Nr	€
ø D=d	B	L				
8	20	100			301B2592104D	68,47
10	20	115			301B2592105D	91,42
12	20	130			301B2592106D	112,41
14	25	140			301B2592107D	145,68
16	25	155			301B2592108D	187,70
18	30	160			301B2592109D	228,65
20	30	180			301B2592110D	294,25
25	40	225			301B2592111D	405,00

Monolitické špirálové frézy v predĺzenej verzii. Konštrukcia nástroja zabezpečuje dostatočnú tuhosť aj pri väčšom vyložení. Určené hlavne na dokončovacie operácie rovinných plôch.

Z3 VALCOVÉ HRUBOVACIE					Nr	€
ø D=d	B	L				
8	20	100			301B2592104H	71,00
10	20	115			301B2592105H	94,80
12	20	130			301B2592106H	116,94
14	25	140			301B2592107H	151,90
16	25	155			301B2592108H	195,82
18	30	160			301B2592109H	239,03
20	30	180			301B2592110H	307,68
25	40	225			301B2592111H	423,56

Monolitické špirálové frézy v predĺzenej verzii. Konštrukcia nástroja zabezpečuje dostatočnú tuhosť aj pri väčšom vyložení nástroja. Určené na hrubovanie pri obrábaní 3D plôch.

Z2 GULOVÉ DOKONČOVACIE					Nr	€
ø D=d	B	L				
8	20	100			301B2592104G	68,47
10	20	115			301B2592105G	91,42
12	20	130			301B2592106G	112,41
14	25	140			301B2592107G	145,68
16	25	155			301B2592108G	187,70
18	30	160			301B2592109G	228,65
20	30	180			301B2592110G	294,25
25	40	225			301B2592111G	405,00

Monolitické špirálové frézy v predĺzenej verzii. Konštrukcia nástroja zabezpečuje dostatočnú tuhosť aj pri väčšom vyložení nástroja. Určené na dokončovacie operácie 3D plôch.



PP10D						HW	
DIAMANTOVÉ FRÉZY ECONOMY Z=1							
ø D	B	L	Z	RH Nr	LH Nr	€	
10	26	75	12	235PP10D102612R	235PP10D102612L	56,80	
12	26	75	12	235PP10D122612R	235PP10D122612L	62,00	
12	34	90	12	235PP10D123412R		95,00	
12	45	95	12	235PP10D124512R		99,00	
16	26	90	16	235PP10D162616R		99,00	
16	34	100	16	235PP10D163416R		82,00	
16	43	110	16	235PP10D164316R		94,60	
18	43	110	20	235PP10D184320R	235PP10D184320L	94,60	
20	43	110	20	235PP10D204320R	235PP10D204320L	94,60	
20	52	115	20	235PP10D205220R		113,40	
20	68	135	20	235PP10D206820R		166,00	

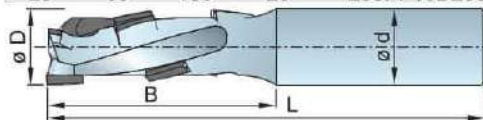

Diamantové frézy v ekonomickom prevedení – výška diamantu 2,7mm.
Počet ostrení maximálne 3X. Vhodné na obrábanie LDTD, DTD, MDF a preglejky.
Určené pre posuvové rýchlosti v rozmedzí 2 - 6/min.



PP09D						HW	
DIAMANTOVÉ FRÉZY SOLID							
ø D	B	L	ø d	Z	RH Nr	LH Nr	€
5	8	55	10	1	235PP09D050810R	235PP09D050810L	91,00
6	12	70	10	1	235PP09D061210R	235PP09D061210L	91,00
6	15	70	10	1	235PP09D061510R	235PP09D061510L	138,00
8	15	70	10	2	235PP09D081510R	235PP09D081510L	143,00
10	15	70	10	2	235PP09D101510R	235PP09D101510L	143,00
10	22	70	10	2	235PP09D102210R	235PP09D102210L	173,00
12	25	70	10	2	235PP09D122510R	235PP09D122510L	207,80
12	25	70	12	2	235PP09D122512R	235PP09D122512L	207,80

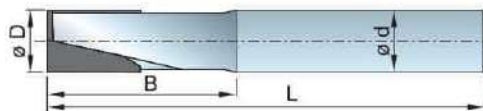

Výkonný diamantový nástroj pri požiadavke na malý rezný priemer nástroja.
Špeciálna konštrukcia nástroja s oceľovou stopkou a HM telom eliminuje riziko zlomenia nástroja. Diamantové frézy s negatívnym sklonom zubov.
Vhodné na obrábanie HPL, cemento-trieskových a cemento-vláknitých dosiek, preglejky, MDF a LDTD. Určené pre posuvové rýchlosti v rozmedzí 2 - 5/min.



PP85D						HW	
DIAMANTOVÉ FRÉZY NESTING UNI Z=3							
ø D	B	L	Z	RH Nr		€	
10	22	72	12	235PP85D122212R		223,80	
12	28	78	12	235PP85D122812R		284,80	
12	38	82	12	235PP85D123812R		324,60	
12	42	92	14	235PP85D144214R		359,20	

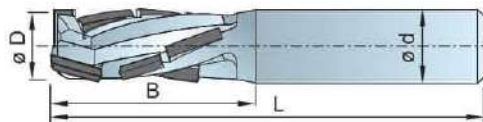

Univerzálne diamantové frézy určené na frézovanie širšieho spektra materiálov metódou „nesting“. Nosič nástroja vyrobený s DENSIMENT-u. Vhodné na obrábanie LDTD, DTD, MDF a preglejky. Určené pre posuvové rýchlosti v rozmedzí 8 - 16/min.



PP93D						HW	
DIAMANTOVÉ FRÉZY NESTING PLUS Z=3							
ø D	B	L	Z	RH Nr		€	
12	24	70	12	235PP93D122412R		322,00	
12	28	75	12	235PP93D122812R		410,00	
16	34	90	16	235PP93D163416R		563,00	

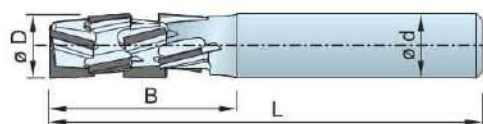

Diamantové frézy špeciálne určené na frézovanie LDTD a DTD metódou „nesting“. Nosič nástroja vyrobený s DENSIMENT-u. Vysoká životnosť nástroja. Určené pre posuvové rýchlosti v rozmedzí 12 - 22/min.



PP81		DIAMANTOVÉ FRÉZY PERFORMANCE Z=3			HW	
ø D	B	L	ø d	RH Nr	LH Nr	€
20	29	90	20	235PP81D202920R	235PP81D202920L	303,40
20	39	100	20	235PP81D203920R	235PP81D203920L	369,20
20	49	110	20	235PP81D204920R	235PP81D204920L	480,00

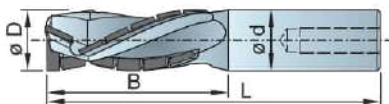

Výkonné diamantové nástroje na formátovanie a frézovanie polodrážok. Výška diamantu 4mm, počet ostrení maximálne 6X. Vhodné na obrábanie LDTD, DTD, MDF a preglejky. Určené pre posuvové rýchlosti v rozmedzí 15 - 22/min.



PP86		DIAMANTOVÉ FRÉZY AXIAL Z=2			HW	
ø D	B	L	ø d	RH Nr	LH Nr	€
16	24	90	25	235PP86D162425R	235PP86D162425L	252,00
25	28	93	25	235PP86D252825R	235PP86D252825L	252,00
25	38	103	25	235PP86D253825R	235PP86D253825L	343,80
25	45	110	25	235PP86D254525R	235PP86D254525L	437,00

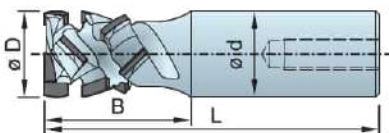

Veľká hodnota axiálneho sklonu zubov dáva týmto nástrojom výnimočné vlastnosti – predĺženie životnosti oproti bežnej konštrukcii, a schopnosť frézovať bez vytrhávania dyhované materiály naprieč vlákien. Obzvlášť vhodný je aj na opracovanie preglejky. Výška diamantu 4mm, počet ostrení maximálne 6X. Vhodné na obrábanie LDTD, DTD, MDF a preglejky. Určené pre posuvové rýchlosti v rozmedzí 11 - 17/min.



PP60		DIAMANTOVÉ FRÉZY HIGH SPEED Z=3			HW	
ø D	B	L	ø d	RH Nr	€	
50	28	85	25	235PP60D502803R	370,00	
50	38	95	25	235PP60D503803R	370,00	

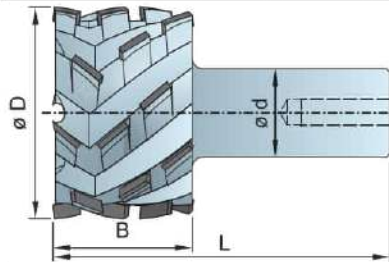

Výkonné diamantové nástroje určené na efektívne formátovanie dielcov a frézovanie polodrážok pri vysokých posuvových rýchlostiach a vysokej kvalite rezu. Veľká hodnota axiálneho sklonu zubov. Výška diamantu 4mm, počet ostrení maximálne 6X. Vhodné na obrábanie LDTD, DTD, MDF a preglejky. Určené pre posuvové rýchlosti v rozmedzí 16 - 32/min. Pre ešte vyššie rýchlosti je možné nástroj dodať aj v prevedení Z=4.



PP08		DIAMANTOVÉ STOPKOVÉ FRÉZY CLAMEX Z=1			HW	
ø D	B	L	ø d	Nr	€	
10	17	70	10	235PP08D0101710R	154,00	

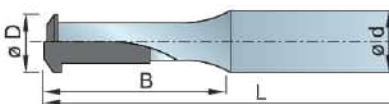

Diamantový nástroj na frézovanie spoja typu CLAMEX na 5-osovom obrábacom centre. HM telom dáva nástroju dostatočnú tuhosť aj pri malom priemere. Určené pre posuvové rýchlosti v rozmedzí 1,5 - 3/min. Kotúčovú verziu nástroja nájdete na strane 1.6.



520 C, E ZÁVRTNÁ FRÉZA		HW			
$\varnothing D$	B	L	Z	Nr	€
35	28	95	2+2	6150520C00000	296,00
35	48	115	2+2	6150520E00000	296,00

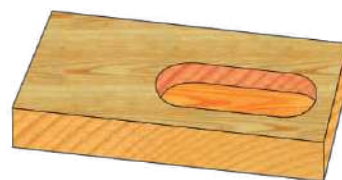
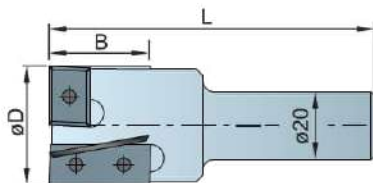

Závrtné frézy osadené typizovanými žiletkami. Obvodové uberacie žiletky sú uložené šikmo, s negatívnym sklonom.



520 F FALCOVACIA FRÉZA		HW			
$\varnothing D$	B	L	Z	Nr	€
50	50	105	2+2	301B1181001	276,00

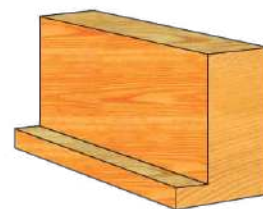
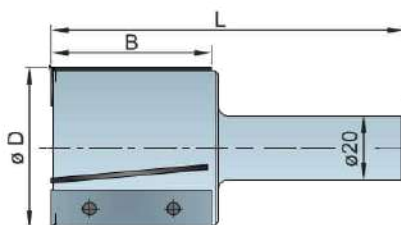

Frézy určené na frézovanie polodrážok – falcov, a na obvodové frézovanie. Obvodové uberacie žiletky sú uložené šikmo, s negatívnym sklonom.



P94 FRÉZY PRE STAVEBNÉ KONŠTRUKCIE		HW				
$\varnothing D$	B	L	$\varnothing d$	Z	Nr	€
30	120	195	30	2	235P94M30120DR	519,75
40	160	235	30	2	235P94M40160AR	714,54
50	210	280	30	2+2	235P945M50210AR	834,80

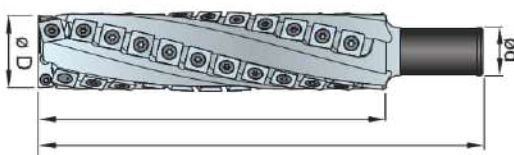

Frézy určené pre 5-osé stavebno-stolárske stroje typu „HUNDEGGER“, určené na frézovanie konštrukčných spojov a obvodové frézovanie tvarových dielcov. Špirálová konštrukcia nástrojov zabezpečuje dobrý odvod triesky a menej zaťažuje rázmi frézovacie vreteno stroja.



625 A ŠPIRÁLOVÉ OBVODOVÉ FRÉZY AXIAL		HW			
$\varnothing D$	B	L	Z	Nr	€
80	115	176	2+2	6150625A00000	1 075,00

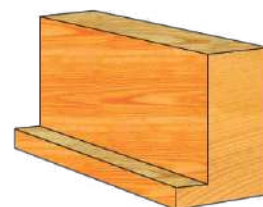
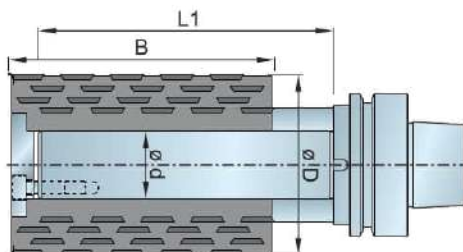

Frézy určené na obvodové frézovanie, plošné zrovnávanie a frézovanie. Žiletky na obvode sú uložené šikmo v skrutkovici, čo dáva nástroju veľmi dobré rezné vlastnosti aj pri väčších úberoch materiálu. Nástroj sa dodáva osadený na upínači HSK63F.



625 E ŠPIRÁLOVÉ OBVODOVÉ FRÉZY		HW			
$\varnothing D$	B	L	Z	Nr	€
100	115	176	3+3	6150625E00000	607,00

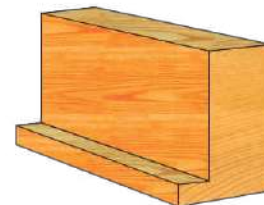
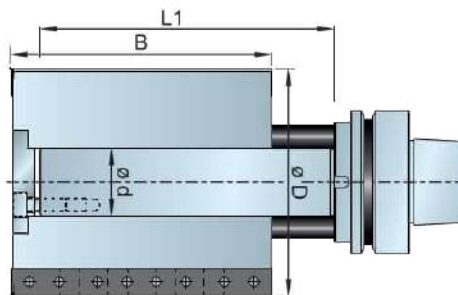

Frézy určené na obvodové frézovanie, plošné zrovnávanie a frézovanie. Žiletky na obvode sú uložené priamo, v skrutkovi. Počet zubov a rezný priemer robia nástroj veľmi výkonným pri obvodovom frézovaní. Nástroj sa dodáva osadený na upínači HSK63F.



NC12M PLOŠNÉ ZROVNÁVACIE FRÉZY		HW					
$\varnothing D$	B	L	$\varnothing d$	Z		Nr	€
60	13	80	12	2	POZ	280NC12M60	108,00
60	13	80	12	2	NEG	280NC12M60N	108,00
80	13	80	20	3	POZ	280NC12M80	148,50
80	13	80	20	3	NEG	280NC12M80N	148,50

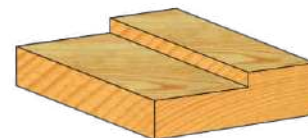
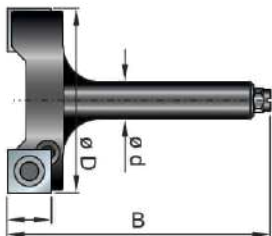

Frézy určené na plošné zrovnávanie povrchov. Osadené typizovanou žiletkou. Nástroje sú určené pre CNC stroje. Nástroje s pozitívne uloženým plátkom sú určené na obrábanie masívu. Nástroje s negatívne uloženým plátkom sú určené na obrábanie aglomerovaných materiálov.



938 OBVODOVÉ ZRÁŽACIE FRÉZY		HW			
$\varnothing D$	B	L	$\varnothing d$	Nr	€
80	50	20	2+2+2	2493064001	453,10

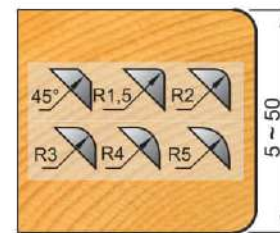
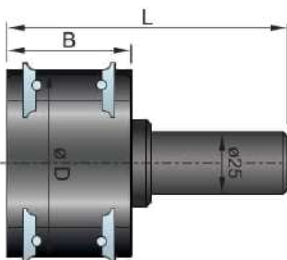

Frézy určené na obvodové frézovanie a súčasné zrážanie jednej alebo oboch hrán obrobku. Nástroj je štandardne osadený zaobľovacími elementami R=3mm.



NC10 UHLOVÉ NASTAVITELNÉ FRÉZY		HW					
$\varnothing D$	B	L	$\varnothing d$	α	Z	Nr	€
105	40	93	20	± 60	2	280NC10M-A	598,00

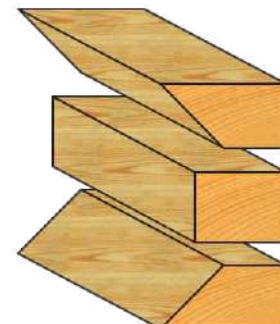
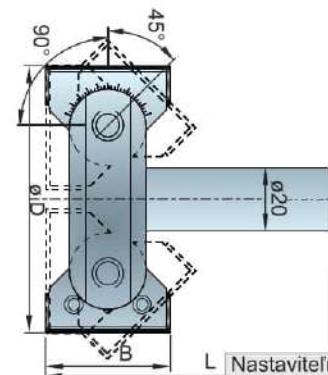

Nastavitelné frézy určené na obvodové frézovanie pod definovaným uhlom. Delenie nóniusu pre nastavenie požadovaného uhla je po 2,5°.

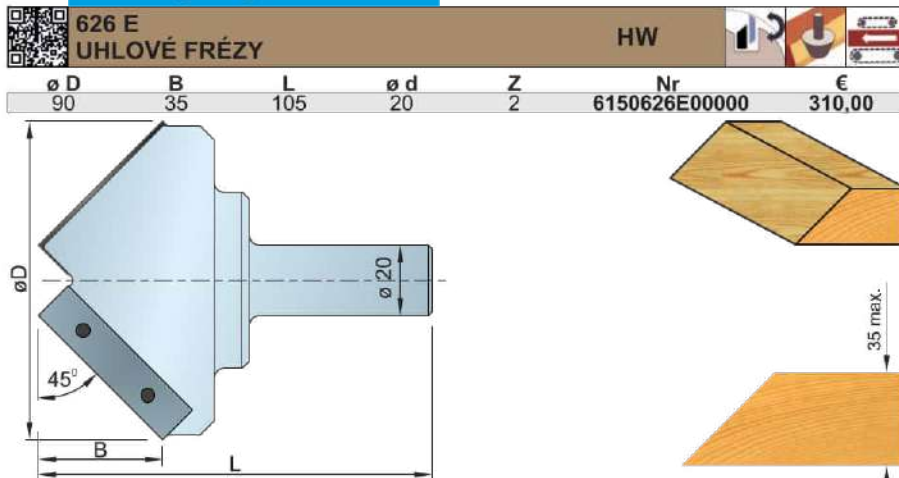

Frézy na frézovanie obvodu pod 45°. Osadené typizovanými žiletkami.

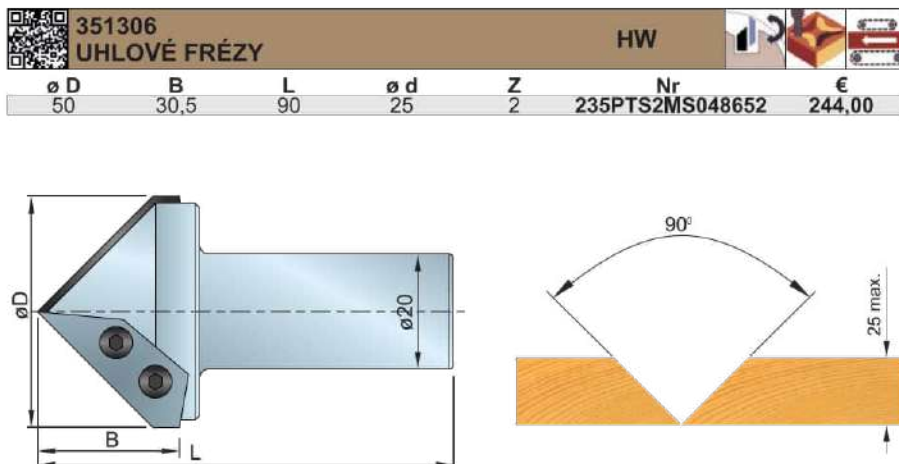

Žiletkové frézy pre efektívne frézovanie tvarových drážok, vyberanie rohov a hlboké gravírovanie. Tuhá konštrukcia nástroja.

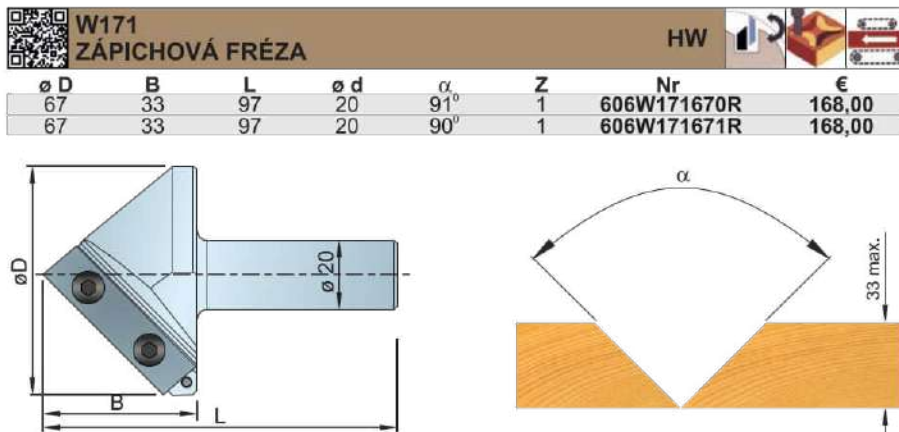

Jednozubé uhlové frézy pre menej náročné aplikácie. Fréza s uhlom 91° je určená pre foldingový systém výroby korpusov. Fréza s uhlom 90° je určená na gravírovanie, zrážanie a profilovanie hrán.

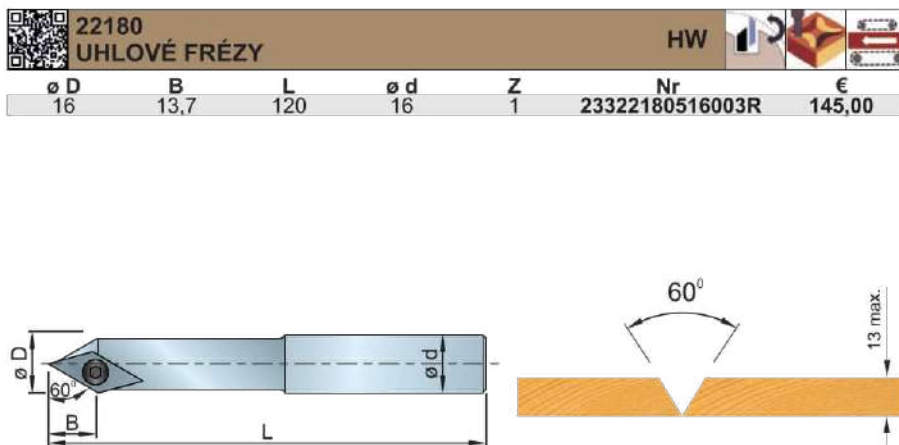

Nástroj špeciálne určený na vyberanie 90° rohov v otvoroch v panelových konštrukciách pre 5-osé centrá. Nástroj je možné použiť aj na gravírovanie.



STOPKOVÁ FLURY HLAVA		SP, HS, HW	
$\varnothing D$	$\varnothing d$	B	Nr
66	25	40-50	7004066040025ZS
			€
			213,00

 *Váš profilový nůž vyrobíme do 48 hodin!*

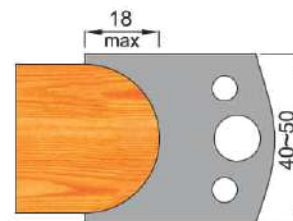
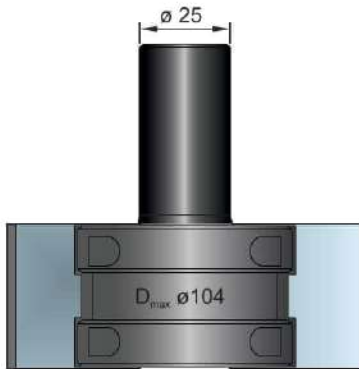

STOPKOVÁ BLANKETOVÁ HLAVA		HS, HW	
$\varnothing D$	$\varnothing d$	B	Nr
78	25	50	1117850
			€
			165,00

 *Váš profilový nůž vyrobíme do 48 hodin!*

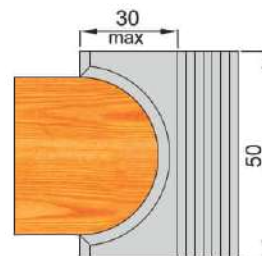
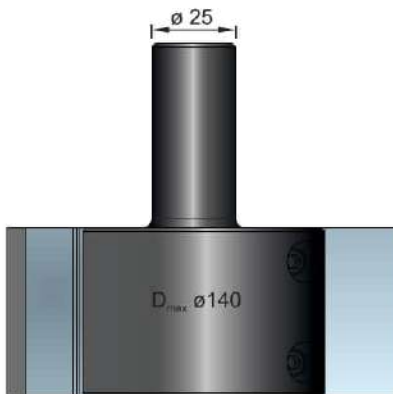

STOPKOVÁ SUPERPROFILOVÁ HLAVA		HW	
TYP		Nr	€
A		280TSP155A	166,00
C		280TSP155C	166,00
D		280TSP155D	166,00

 *Váš profilový nůž vyrobíme do 48 hodin!*

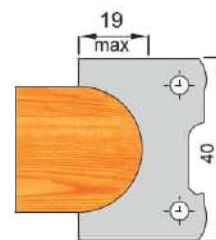
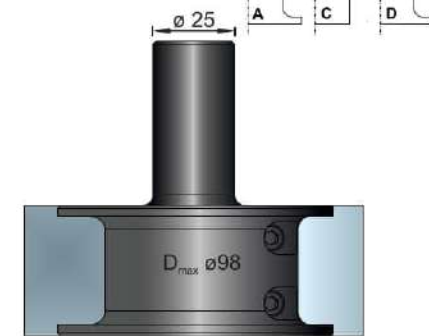

UHLOVÉ NASTAVITELNÉ FRÉZY		HW	
$\varnothing D$	B	L	$\varnothing d$
61	31	90	20
			Nr
oporný nůž			54015209V
žiletka T04F-CR			54015207V
			€
			247,00
			24,58
			18,50

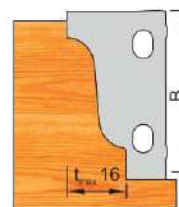
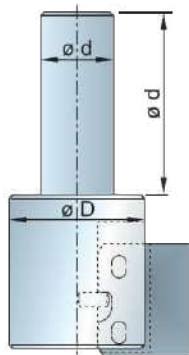

OBSAH



QR	STOPKOVÁ SUPERPROFILOVÁ HLAVA PLOŠNÁ HW				HW	Icons
ø D	B	L	ø d	Z	Nr.	€
90	35	105	20	2	6150626E00000	310,00

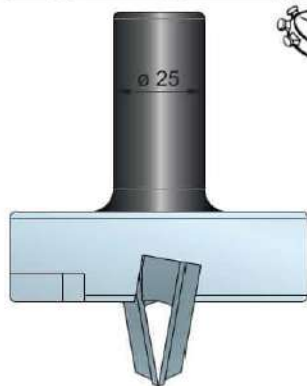

Váš profilový nôž vyrobíme do 48 hodín!

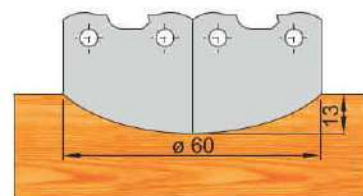

QR	351306 UHLOVÉ FRÉZY HW			HW	Icons
unášač	ø D	ø d	L	Nr.	€
profilový nôž	45	16	95,5	235PTS2MS064384 54014813U	155,00 31,38

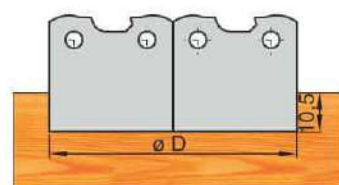
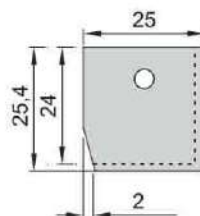

QR	22510 STOPKOVÝ OBVODOVÝ UNÁŠAČ HW					HW	Icons
Unášač malý	B	ø D max	ø D min	t max	Nr.	€	
Unášač veľký	40	34	20	7	23322510000006R	287,00	
Žiletka	80	59	35	12	23322510000206R	305,00	
Žiletka	50x24.8x2.2				233725106500000	67,00	

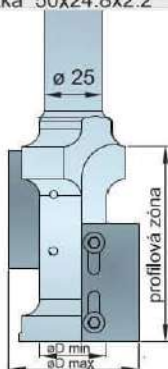

Váš profilový nôž vyrobíme do 48 hodín!

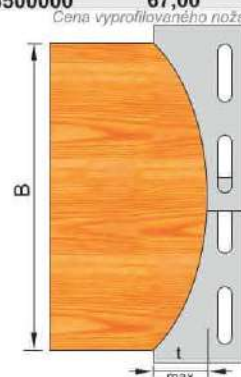

QR	626 - A UNIVERZÁLNY GRAVÍROVACÍ NOSIČ HW			HW	Icons
unášač	B	Z	Nr.	€	
Žiletka	25	1	301B2471001 301B2471002-7	147,80 18,50	

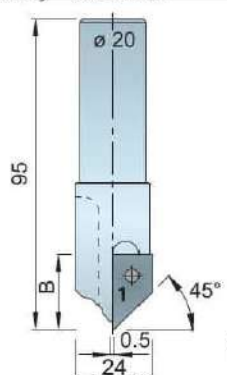

príklady profilov

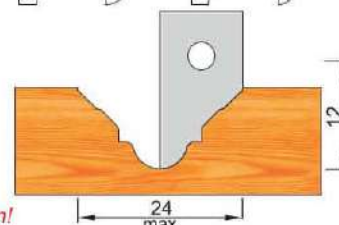
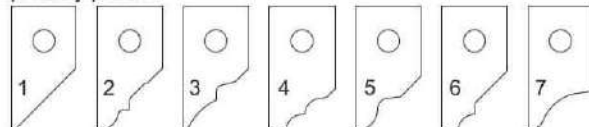

Váš profilový nôž vyrobíme do 48 hodín!



626 GH
STOPKOVÁ DVIERKOVÁ SADA FRÉZ HW

ø D	B	L	Z	Nr.	€
105	44	100	2+2	6150626G00000	566,00
90	44	100	2+2	6150626H00000	376,00

Frézovacia sada nástrojov na rámovú konštrukciu nábytkových dvierok. Dvierka je možné osadiť so vsadenou, alebo lištovanou výplňou.



626 ST
STOPKOVÁ DVIERKOVÁ SADA FRÉZ HW

ø D	B	L	Z	Nr.	€
84	30	93	2+2	6150626S00000	440,00
64	30	93	2	6150626T00000	288,00

Frézovacia sada nástrojov na rámovú konštrukciu nábytkových dvierok so vsadenou výplňou.



627-E
STOPKOVÁ VÝPLŇOVÁ FRÉZA HW

ø D	B	L	ø d	T	Z	Nr.	€
108	15	90	20	48	3	6150627E00000	531,20

Stopková fréza pre CNC frézovačky na frézovanie rustikálnych výplní.



627 F
STOPKOVÁ VÝPLŇOVÁ FRÉZA HW

ø D	B	L	Z	Nr.	€
110	16	90	3	6150627F00000	588,00

Stopková fréza pre CNC frézovačky, s možnosťou osadenia troch rôznych typov tvarových nožov.

626 M
FRÉZOVACÍ SET NA DVIERKA

HW



	ø D	B	L	Z	Nr	€
1	60	20	90	2	6150626L10000	245,60
2	43	20	90	2	6150626L20000	234,40
3	32	20	90	2	6150626L30000	223,20
4	30	20	90	2	6150626L40000	223,20
SET	30-60	20	90	2	6150626L00000	926,40

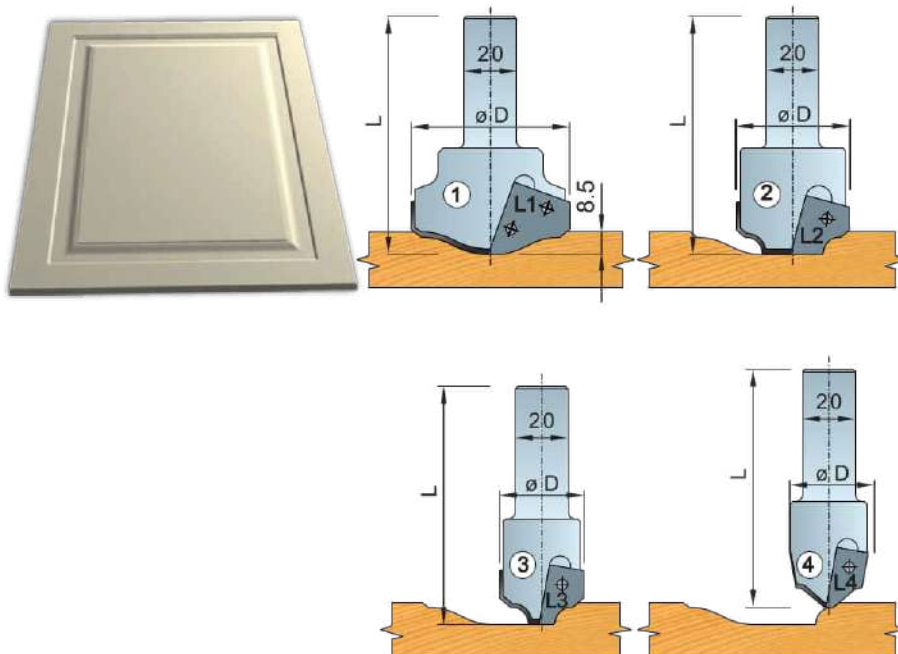

Frézovací set na výrobu imitácie rámovej konštrukcie MDF dvierok.

626 M
FRÉZOVACÍ SET NA DVIERKA

HW



	ø D	B	L	Z	Nr	€
1	65	20	110	2+2	6150626M10000	352,00
2	50	20	95	2	6150626M20000	234,40
3	24	20	95	1	6150626M30000	161,60
4	24	20	95	1	6150626M40000	161,60
SET	24-65	20	95	1-2+2	6150626M00000	909,60

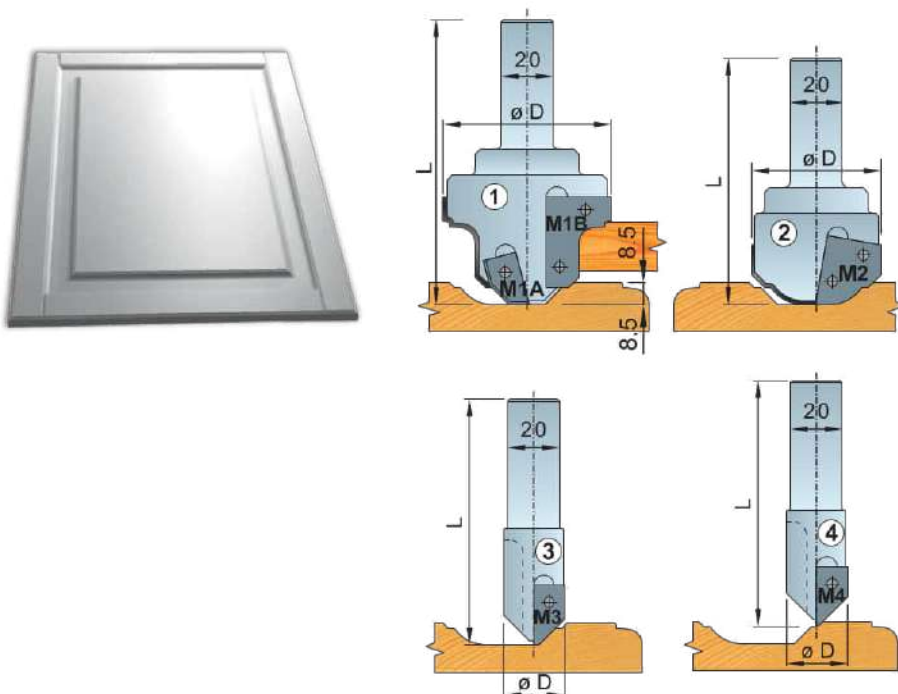

Frézovací set na výrobu imitácie rámovej konštrukcie MDF dvierok. Sada obsahuje nástroje na frézovanie tvarovej drážky profil/výplň a nástroj na obvodové frézovanie.



CNC UPINÁKY



eshop.woodb.sk



HSK 63 KLIŠŤINOVÉ UPÍNAČE - ŠTANDARD

Klieštinové upínače - štandard

	klieština	L	ø D1	↺	Nr	€
HSK63F	ER32	75	50	RH	232WF204P	90,20
HSK63F	ER32	75	50	LH	232WF214L	122,00
HSK63F	ER40	75	63	RH	232WF222P	102,50
HSK63F	ER40	75	63	LH	232WF232L	110,70
HSK63E	ER40	76	63	RH	232WE222P	184,00
HSK63E	ER40	76	63	LH	232WE232L	174,00

Klieštinové upínače - INOX

	klieština	L	ø D1	↺	Nr	€
HSK63F	ER32	74	50	RH	606T118980RAI	133,20
HSK63F	ER40	77	63	RH	606T118976RAI	121,00

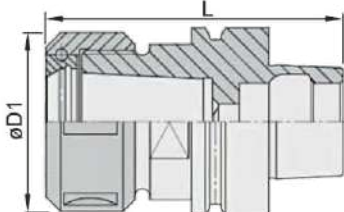

Presné nástrojové upínače pre klieštiny typu "ER". Trieda INOX je určená pre obrábanie v prostredí zvýšenej vlhkosti, prípadne zvýšených abrazívnych účinkov obrábaného materiálu.



HSK 63-PREZISO KLIŠŤINOVÉ UPÍNAČE PRE VYSOKÉ OTÁČKY

	klieština	L	ø D1	↺	Nr	€
HSK63F	462E	75	50	RH	23321017000063F	212,18

Upínací klúč PREZISO 233391550500000 31,00

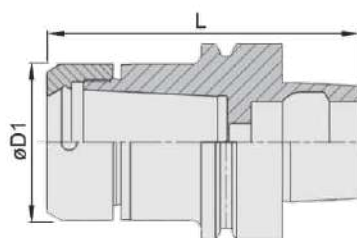

Vysoko presný nástrojový upínač určený pre max.otáčky do 30 000/min. Veľmi tichá prevádzka.



HSK 63-HYDRO VYSOKO PRESNÉ HYDRAULICKÉ UPÍNAČE

	d	L	ø D1	↺	Nr	€
HSK63F	20	80	53	RH/LH	111HSK63FD20	329,00
HSK63F	25	84	53	RH/LH	111HSK63FD25	329,00

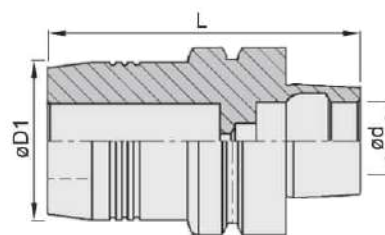

Vysoký moment upnutia nástroja a zvýšená centricita upínania.



ISO KLIŠŤINOVÉ UPÍNAČE - ŠTANDARD

	klieština	L	ø D1	↺	Nr	€
ISO 30	ER32	55	50	RH	232W404	139,00
MORBIDELLI	ER32	50	50	RH	232W502	77,90
ISO 30	ER40	60	63	RH	232W522	98,40
ISO 30	ER32	73	50	RH	606T118850R	209,90
ISO 40	ER40	73	75	RH	606T118870R	220,00

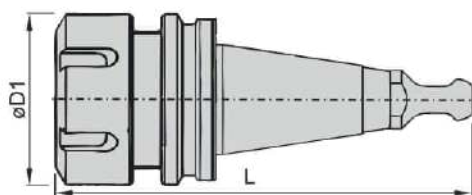

Upínacie čapy

280CD01M ... 24,20



280CD01M AA9 BA9 CA9 DA9 EA9

Klieštinové upínače pre klieštiny ER. Podľa typu stroja je potrebné k upínaču dokúpiť upínací čap. Nad rámec uvedených čapov máme na vyžiadanie v ponuke ich rozsiahlejší sortiment.



HSK HRIADEL'

Upínacie hriadele pre kotúčové nástroje HSK63F

	ø d	L	ø D1	Nr	€
HSK63F	30	60	63	232HSK63F30060	153,60
HSK63F	30	95	63	232HSK63F30095	161,00
HSK63F	30	105	63	232HSK63F30105	161,00
HSK63F	30	135	63	232HSK63F30135	179,00
HSK63F	30	180	63	232HSK63F30180	190,00

Upínacie hriadele pre kotúčové nástroje HSK85 - Weining Powerlock

	ø d	L	ø D1	Nr	€
HSK85	30	60	85	232HSK85W30060	267,90
HSK85	30	100	85	232HSK85W30130	267,90
HSK85	30	150	85	232HSK85W30150	305,80
HSK85	40	80	85	232HSK85W40080	259,20
HSK85	40	130	85	232HSK85W40130	279,90
HSK85	40	240	85	232HSK85W40240	354,30

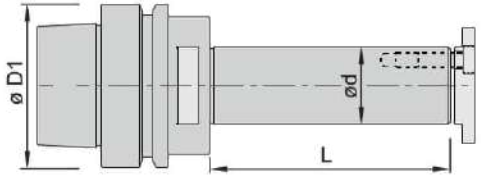

HSK upínacie hriadele pre kotúčové frézy. Vždy uprednostňovať minimálnu potrebnú dĺžku. Vhodné je zkompletovanú zostavu nástroja a upínača zaslať na kontrolu vyváženia celého



PREDLŽOVACIE UPÍNAČE

ø D	ø d	L	ø D1	↻	Nr	€
20	ER 16	160	22	RH	606T121016200160	85,00
20	ER 20	160	28	RH	606T121020200160	90,00

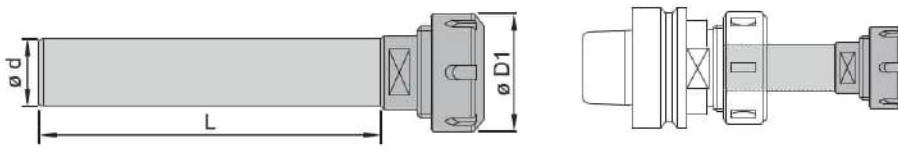

Predlžovacie upínače je možné kombinovať s klieštinnými nástrojovými upínačmi a dosiahnuť tak aj do väčších hĺbok - najmä pri 3D obrábaní.



STOPKOVÉ PRÍRUBOVÉ UPÍNAČE

ø d	ø D1	L	Nr	€
20	22	90	606T128141R	106,60
20	30	90	606T128140R	106,60
25	30	90	606T128145R	106,00

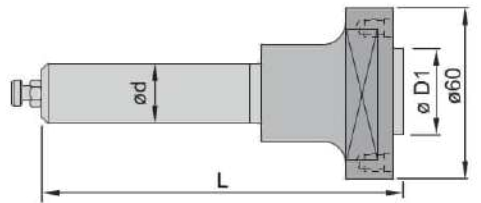

Upínače určené pre drážkovacie a pilové kotúče do priemeru 200mm. Nástroje je potrebné upraviť príslušnými upínacími otvormi so zahĺbením. Určené pre nenáročné aplikácie.



HSK PRÍRUBOVÉ UPÍNAČE

	ø d	L	ø D1	D _{max} pil. kotúča	Nr	€
HSK63F	30	105	65	260	233394980065630	355,00
HSK63F	30	100	110	350	606T128165R	385,00

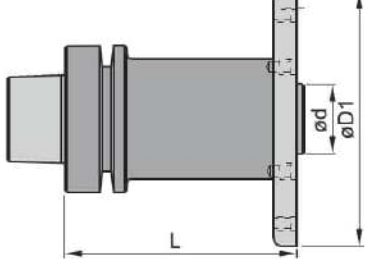

Upínače na pilové kotúče pre 5-osé stroje. Celistvá konštrukcia upínača zaisťuje maximálnu presnosť a tuhosť. Pilové kotúče, na ktorých vyhotovenie sú kladené osobitné nároky, je potrebné upraviť príslušnými upínacími otvormi so zahĺbením.



KLIŠTINY ER

ER11 (L=18mm)

ø D	Nr.	€
1	232ER1101	23,00
2	232ER1102	23,00
3	232ER1103	23,00
4	232ER1104	23,00
5	232ER1105	23,00
6	232ER1106	23,00
7	232ER1107	23,00

ER16 (L=28mm)

ø D	Nr.	€
2	232ER1602	13,80
3	232ER1603	13,80
4	232ER1604	13,80
5	232ER1605	13,80
6	232ER1606	13,80
8	232ER1608	13,80
10	232ER1610	13,80

ER20 (L=32mm)

ø D	Nr.	€
3	232ER2003	13,80
4	232ER2004	13,80
5	232ER2005	13,80
6	232ER2006	13,80
8	232ER2008	13,80
10	232ER2010	13,80
12	232ER2012	13,80
13	232ER2013	13,80

ER25 (L=34mm)

ø D	Nr.	€
2	232ER2502	20,50
3	232ER2503	13,80
4	232ER2504	13,80
5	232ER2505	13,80
6	232ER2506	13,80
8	232ER2508	13,80
10	232ER2510	13,80
12	232ER2512	13,80
14	232ER2514	13,80
16	232ER2516	13,80

ER32 (L=40mm)

ø D	Nr.	€
3	232ER3203	15,50
4	232ER3204	15,50
5	232ER3205	15,50
6	232ER3206	15,50
8	232ER3208	15,50
10	232ER3210	15,50
12	232ER3212	15,50
14	232ER3214	15,50
16	232ER3216	15,50
18	232ER3218	15,50
20	232ER3220	15,50

ER40 (L=46mm)

ø D	Nr.	€
3	232ER4003	20,50
4	232ER4004	20,50
5	232ER4005	20,50
6	232ER4006	20,50
8	232ER4008	20,50
10	232ER4010	20,50
12	232ER4012	20,50
14	232ER4014	20,50
16	232ER4016	20,50
18	232ER4018	20,50
20	232ER4020	23,30
25	232ER4025	20,50
30	232ER4030	20,50

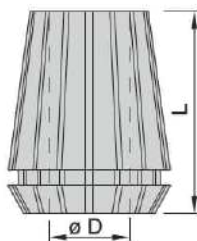

Precízna klieština do unášačov pre upnutie stopkových nástrojov.

Tolerancia pre upnutie +0/-0,5mm. Povrchovo upravené pre zamedzenie hrdzavenia.

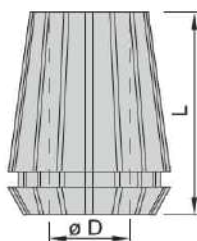
KLIŠTINY DIN 6388
462 E (L=52)

ø D	Nr.	€
2	232E46202	29,00
3	232E46203	29,00
4	232E46204	29,00
5	232E46205	29,00
6	232E46206	30,80
8	232E46208	30,80
10	232E46210	30,80
12	232E46212	30,80
14	232E46214	30,80
16	232E46216	30,80
18	232E46218	30,80
20	232E46220	30,80
25	232E46225	30,80

Zvlášť presné klieštiny pre vyššiu úroveň upnutia nástroja v držiaku. Tolerancia pre upnutie +0/-0,01mm. Menej strmý kužel (v porovnaní s ER), dlhšia plocha upnutia stopky zabezpečujú vysoký upínací moment a zlepšenú centricitu upínania. Doporučujeme pre priemyselné nasadenie so zvýšenými nárokmi na obrábanie a dosahované rýchlosti posuvu.



REDUKCIE PRE HYDRO UPÍNAČE

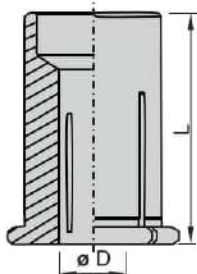

D20 (L=54mm)

ø D	Nr.	€
8	232H2008	85,80
10	232H2010	85,80
12	232H2012	85,80
14	232H2014	85,80
16	232H2016	85,80

D25 (L=60mm)

ø D	Nr.	€
12	232H2512	94,40
14	232H2514	94,40
16	232H2516	94,40
18	232H2518	94,40
20	232H2520	94,40

Brúsený, vysoko presný dizajn redukcie. Na použitie vo všetkých skľučovadlách TRIBOS a HYDRO.





UPÍNACIE MATICE

Pevné						
Pre upínač		øD	ød	B	Nr	€
ER32	RH	50	M40x1,5	23	606Z091001R	29,20
ER32	LH	50	M40x1,5	23	606Z091001L	29,20
ER40	RH	63	M50x1,5	25	606Z091002R	34,90
ER40	LH	63	M50x1,5	25	606Z091002L	34,90
462 E	RH	63	M48x2	25	606Z091202R	45,00

Otočné						
Pre upínač		øD	ød	B	Nr	€
ER32	RH/LH	50	M40x1,5	23	606Z091101R	49,50
ER40	RH/LH	63	M50x1,5	25	606Z091102R	57,70
462 E	RH/LH	63	M48x2	25	606Z091203R	71,28

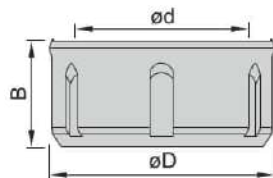

Otočná matica pre klieštínové upínače s guľôčkovými ložiskami. Zlepšuje presnosť aj tuhosť upnutia klieštínových upínačov. Vďaka tomu eliminuje vyťahovanie nástroja z upínača.



UPÍNACIE KLÚČE

Hákové				
Pre upínač		ø D	Nr	€
ER32		50	606Z052401N	21,00
ER40		63	606Z052402N	24,50
462 E		60	233391550500000	31,00

Nástrčné				
Pre upínač		ø D	Nr	€
ER32		50	606Z052401N	21,60
ER40		63	606Z052402N	25,70

Nástrčné pre minimatice				
Pre upínač		ø D	Nr	€
ER16		22	606Z052505N	24,60
ER20		28	606Z052508N	25,60

Momentový kľúč				
Pre upínač		ø D	Nr	€
ER32		50	606Z052713N	144,00
ER40		63	606Z052714N	170,00



CLAMPER HSK63

FIX			NASTAVITELNÝ		
Nr.	€		Nr.	€	
232VE240	195,-		606T139163N	230,70	



V prípravku je upínač bezpečne fixovaný pre bezpečnú výmenu nástrojov v upínači. Prípravok chráni dosadacie a upínacie plochy upínačov, čím zamedzuje poškodeniu vretena stroja.



THM

ø D		Nr	€
HSK 63F		606T137263N	57,70
ER32		606T137532N	27,80
ER40		606T137540N	29,80
Sada kief D3-25		606X137004N	28,40
Protect		606PROTECT400	15,40



Sortiment určený pre starostlivosť o nástrojové upínače a klieštiny. Prípravok Protect naneste na funkčné plochy upínača a nechajte pôsobiť. Následne plochy vyčistíte kužeľovými stierkami a kefou. Prípravok odstraňuje koróziu a nalepené prachové častice. Súčasne povrch aj impregnuje a chráni voči korózii.



KONTROLNÝ TRŇ

ø D	L	ø d	Nr.	€
HSK 63F	250	40	23217109016002	380,90

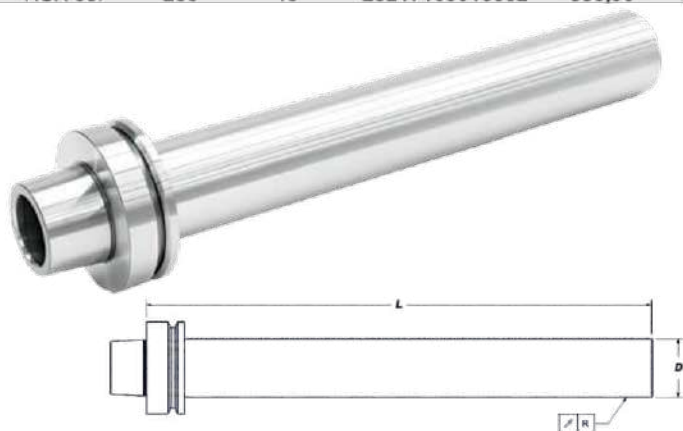

Presný kontrolný trň sa používa na nastavovanie a kontrolu referenčných bodov a polôh CNC strojov. Je dodávaný spolu s výstupným meracím protokolom. Garantovaná presnosť 0,003mm. Meracia valcová časť je kalená.



3D TESTER

ø D	Nr.	€
3D tester	270W85290100	498,00
Merací hrot L=25mm	270W85290102	27,30
Merací hrot L=65mm	270W85290104	45,52

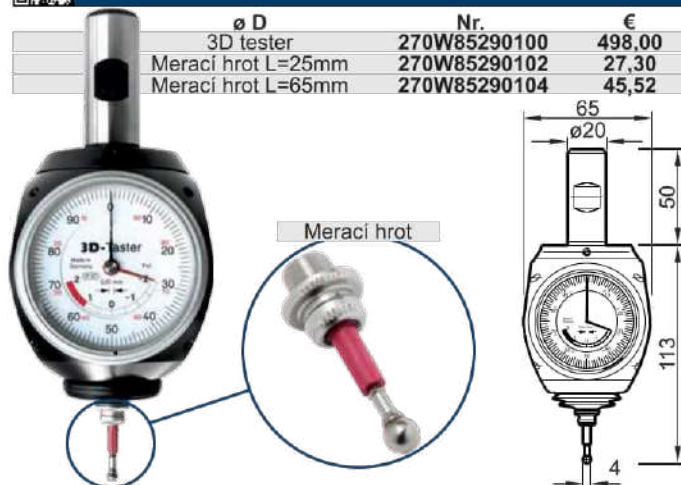

3D tester sa používa predovšetkým na definovanie nulového bodu obrobnku. Je možné ho použiť aj na zistenie rovnosti stola, alebo zapoločovanie obrobnku.



Z-ZERO

H	Nr.	€
100	270W85900018	485,00



Prístroj sa používa na nastavenie presnej dĺžky nástroja odmeraním priamo v CNC stroji. Je možné ho použiť aj na stanovenie presnej výšky obrobnku.



DIGITÁLNE MERADLO PRE NÁSTROJE Z=3

ø D	Nr.	€
4,40	606CDIGITZ3	234,-

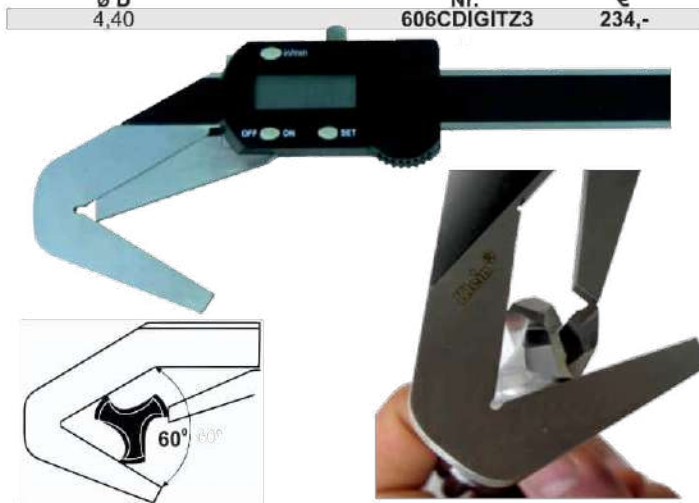

Meradlo sa používa na meranie priemeru trojzubých nástrojov. Presnosť merania je 0,05mm.



PRE-SET P368 HSK63F

H	ø D	Nr.	€
300	250	606P368LRHSK	2 960,-
300	250	606P368LRISO	3 980,-



Merací prístroj na presné stanovenie výšky a priemeru nástroja s dvoma samostatnými displejmi. Meranie je možné v absolútnych hodnotách od nulového bodu, prípadne inkrementálne. Napájanie je pomocou batérií. Presnosť merania je 0,01mm. Prístroj je možné dodať aj pre nástrojové upínače ISO 30,40 a 50, HSK 63A, B, C, D a E.



PRE-SET PRIME HSK63F

H	ø D	Nr.	€
300	400	606P368XL	3 600,00



Komplexný merací kamerový prístroj osadený 19" LCD. Umožňuje správu nulových bodov až pre 50 strojov. Umožňuje odmeriavanie uhlov, rádiusov a dĺžok. Je možné porovnávanie medzi požadovanou a skutočnou geometriou. Možný je aj reálny pohľad na reznú hranu nástroja pri 40 násobnom zväčšení. Prístroj je potrebné okrem elektrickej siete (230V) pripojiť aj na tlakový vzduch. Presnosť merania je 0,001mm. Prístroj je možné dodať aj pre nástrojové upínače ISO 30,40 a 50, HSK 63A,B,C,D a E.



MTS10 ODSÁVACIA TURBÍNA - TURBO SYSTEM

ø D	klieština	L1	H	↻	Nr	€
80	ER32	15	44	RH	235MTS10R32080R	270,20
100	ER32	15	44	RH	235MTS10R32100R	270,20
80	ER40	15	44	RH	235MTS10R40080R	270,20
100	ER40	15	44	RH	235MTS10R40100R	270,20
80	462 E	15	44	RH	235MTS10R25080R	270,20
100	462 E	15	44	RH	235MTS10R25100R	270,20

ø 80 - n max 24.000 / min.

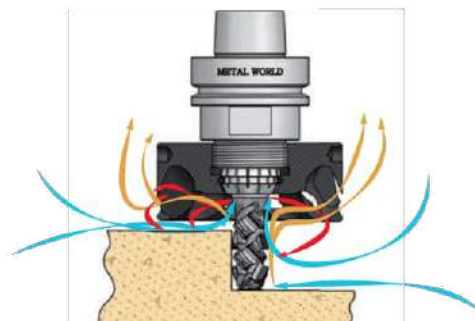

ø 100 - n max 21.000 / min.

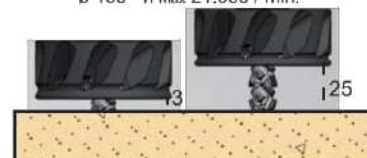

Odsávacia turbína generuje dodatočný podtlak, ktorý napomáha dostať triesku do vzhnosu. Významne prispieva k čistote obrábaného priestoru obzvlášť pri Nestingovom obrábaní.



MTS40 ODSÁVACIA TURBÍNA - TURBO SYSTEM

ø D	klieština	L1	H	↻	Nr	€
100	ER32	15	40	RH	235MTS40R32100R	380,40
100	ER40	15	40	RH	235MTS40R40100R	380,40
100	462 E	15	40	RH	235MTS40X25100R	380,40

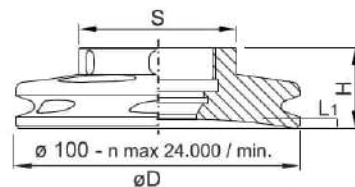
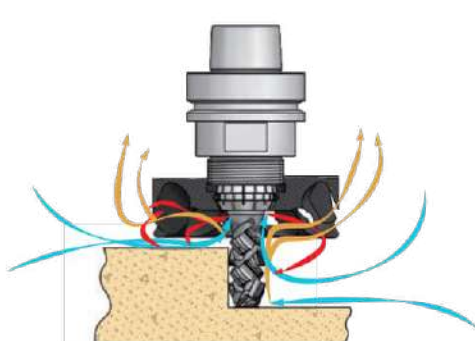

ø 100 - n max 24.000 / min.

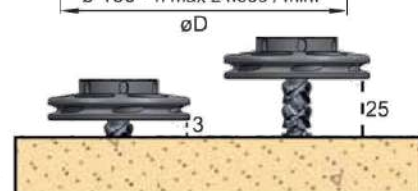

Odsávacia turbína generuje dodatočný podtlak, ktorý napomáha dostať triesku do vzhnosu. Významne prispieva k čistote obrábaného priestoru obzvlášť pri Nestingovom obrábaní.



21044 ADAPTÉR PRE HYDRO BHX

ø D	ø D1	L1	A	ø d	↻	Nr	€
28 (ER16)	32	75	28,5	25	RH	23321044000010R	195,20

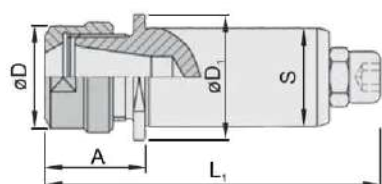

Adaptér pre hydraulické upínanie strojov BHX zabezpečujúci rýchlu výmenu nástrojov pri zachovaní pôvodnej dĺžky nástroja bez potreby editácie.



ORDER

	Nr	€
Box D=4	BP2001	1,50
Box D=6	BP2003	1,50
Box D=10	BP2005	1,50
Box D=20	BP2010	1,50
Box D=25	BP2011	1,50
Box HSK 50	BP2053	2,70
Box Klieština 32	BP2319	1,70



Swing Box 100x100/4	BP2249	4,60
---------------------	--------	------

ORDER prehľadne zaskladní vaše HSK upínaky a zamedzí ich poškodeniu čívermi, nesprávnym skladovaním.

Požadovaná konfigurácia CNC agregátu je definovaná voľbou vstupného pripojenia pre konkrétny typ stroja, voľbou jeho dĺžky a voľbou výstupného upnutia nástroja. Každý druh obrábacej jednotky môže byť teda modulárne kombinovaný dole uvedenými tromi možnosťami.

VSTUPNÉ PRIPOJENIE

	 HSK Biesse	 HSK Busellato	 HSK Felder
	 HSK Homag	 HSK IMA	 HSK Masterwood
	 HSK SCM	 HSK SCM	 HSK Weinig























Pripojenie obrábacej jednotky na motor odpovedá konkrétnemu typu stroja. Každý výrobca používa svoj vlastný koncept predprípravy jej upnutia.

DĹŽKOVÉ VYHOTOVENIE

	KRÁTKY 	STREDNÝ 	DLHÝ 
--	---	---	---

Obrábacie jednotky sú vyhotovené v troch rozličných dĺžkach podľa možnosti zaťaženia pri obrábaní, ako i zákazníckych prevádzkových potrieb.

VÝSTUPNÉ PRIPOJENIE

	 Kombinácia pilový kotúč a weldon upnutie	 Frézovací hriadeľ	 Frézovací hriadeľ
	 Upnutie pilový kotúč medzi príruby	 Weldon upnutie	 Pilový kotúč a weldon upnutie
	 Weldon upnutie	 Frézovací nástroj na krátky čap so štyrmi skrutkami	 Weldon upnutie
	 Pilový kotúč, klieštínové upnutie ER	 Klieštínové upnutie ER	 Klieštínové upnutie ER
	 Pilový kotúč	 Klieštínové upnutie ER	 Upínanie Solidfix Adaptér Solidfix vložíte do agregátu s už upnutým a zameraným nástrojom.
	 Klieštínové upnutie ER	 Upnutie pilový kotúč medzi príruby	 Solidfix ER32 pre stopkové nástroje
	 Klieštínové upnutie ER	 Weldon upnutie	 Solidfix PRÍRUBA pre pilové kotúče

Výstup obrábacej jednotky odpovedá zákazníckym požiadavkám na upnutie nástroja.

MONO



Horizontálny agregát s jedným výstupom. Určený hlavne pre stopkové frézy a vrtáky, alebo pílové kotúče a kotúčové frézy menších priemerov.

cena na vyžiadanie

MONO R



Horizontálny agregát s jedným výstupom a redukovanými otáčkami. Určený hlavne pre kotúčové frézy a pílové kotúče.

cena na vyžiadanie

DUO



Horizontálny agregát s dvoma výstupmi. Určený hlavne pre stopkové frézy a vrtáky, alebo pílové kotúče a kotúčové frézy menších priemerov.

cena na vyžiadanie

QUATTRO



Horizontálny frézovaco-vrtací agregát so štyrmi konfigurovateľnými výstupmi pre stopkové nástroje a drážkovačie / pílové kotúče.

cena na vyžiadanie

FLEX D



Uhlový agregát s manuálne nastaviteľným uhlom a digitálnym číselníkom. Vhodný pre vrtáky, stopkové frézy a drážkovačie kotúče.

cena na vyžiadanie

FORTE



Horizontálny agregát s osovo posunutými dvoma výstupmi. Možnosť konfigurácie pre stopkové aj kotúčové nástroje. Ideálny pre „dlabacie frézy“.

cena na vyžiadanie

ANGULO



Frézovací agregát na dokončovanie pravouhlých rohov vo vybraniach - otvory pre obojstranne lištované výplne v dverkách a dverách.

cena na vyžiadanie

SUBIO



Frézovaco-vrtací agregát pre operácie na spodnej ploche dielca.

cena na vyžiadanie

MULTI H3



Vrtací agregát do hrany s tromi výstupmi určený pre nestingové stoly, kde je dielec upnutý priamo na stole – vzdialenosť osi vrtáka od plochy stola je 8mm. Možná rozteč medzi jednotlivými vrtákmi 20 a 32mm.

cena na vyžiadanie

MULTI H3+



Vrtací agregát do hrany s tromi výstupmi pre stroje s trámčovým stolom, alebo dielcom upnutým na pätkách. Možná rozteč medzi jednotlivými vrtákmi 20 až 32mm.

cena na vyžiadanie

MULTI V



Vrtací agregát do plochy. Možný počet vrtákov 3 až 13.

cena na vyžiadanie

RETINO H



Horizontálny dlabací agregát pre ostrohranné otvory od 3,6 do 16mm.

cena na vyžiadanie

FLOATING V



„Plávajúci“ agregát v osi Z. Frézovaná hĺbka je vždy konštantná, agregát kopíruje hornú plochu dielca. Nástroj je v agregáte upnutý pomocou upínača, takže je možná jeho jednoduchá výmena za iný nástroj. Vhodný na frézovanie do plochy, alebo hrany dielca s hornou referenčnou plochou.

cena na vyžiadanie

FLOATING V C



„Plávajúci“ agregát v osi Z. Frézovaná hĺbka drážky je vždy konštantná, agregát kopíruje hornú plochu dielca. Určený pre frézovanie ozdobných drážok v ploche dielca. Upnutie pre nástroje so stopkou 10 alebo 16mm. Výhodou je nízka výška.

cena na vyžiadanie

FLOATIG HS



„Plávajúci“ agregát v osi Z pre kotúčové nástroje.

cena na vyžiadanie

LIVELLO



Špeciálny agregát na horné a spodné frézovanie hrany dielca. Dva samostatné nástroje kopírujú hranu a eliminujú tak hrúbkovú nepresnosť dielca - frézovaný profil je tak vždy rovnaký na hornej aj spodnej strane

cena na vyžiadanie

SIMOLO



Excentrický brúsny agregát v priemeroch 50, 125 a 150mm.

cena na vyžiadanie

ZUCCO



Vibračný brúsny agregát osadený brúsnu pätkou 93x175mm.

cena na vyžiadanie

COLLEVO



Agregát s brúsnym pásmom 100x560mm určený na hrany dielcov.

cena na vyžiadanie

SECO



Agregát vybavený oscilačným nožom pre delenie tenkých a mäkkých materiálov – papier, látka, koža, mäkké plasty.

cena na vyžiadanie

Nad rámec prezentovaných druhov obrábacích jednotiek ponúkame možnosť ich zákazkovej výroby pre špeciálne účely.



ONE BLADE

	cena od 2 000,-€
H	100/145/180
n_{max} vstup	15 500
n_{max} výstup	10 850
d PK	35
D PK _{max}	240 (pre H=180)
mazanie	plastické mazivo



Jednovýstupový pevný agregát pre drážkovacie a pilové kotúče. Dodáva sa v troch dĺžkových variantoch. Upinanie agregátu sa definuje podľa konkrétneho typu stroja.

TILT

	cena od 2 000,-€
H	115
n_{max} vstup	15 500
n_{max} výstup	15 500
D	2-16 (ER25)
mazanie	plastické mazivo

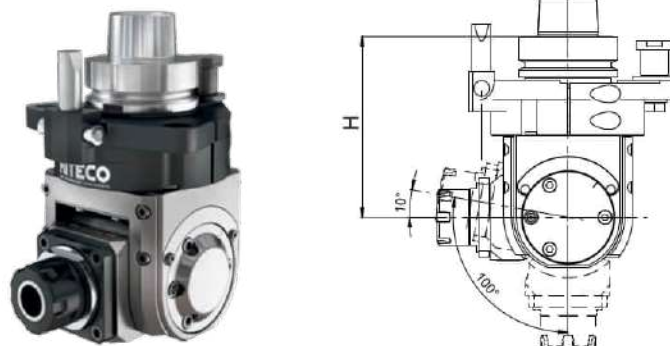

Jednovýstupový uhlovo nastaviteľný agregát určený na vŕtanie a menej náročné frézovanie. Nastavenie uhla je mechanické, podľa stupnice. Upinanie agregátu sa definuje podľa konkrétneho typu stroja.

TWIN

	cena od 2 000,-€
H	100/145/180
n_{max} vstup	10 850
n_{max} výstup	15 500
D1 RH	2-20 (ER32)
D1 LH	2-16 (ER25)
mazanie	plastické mazivo

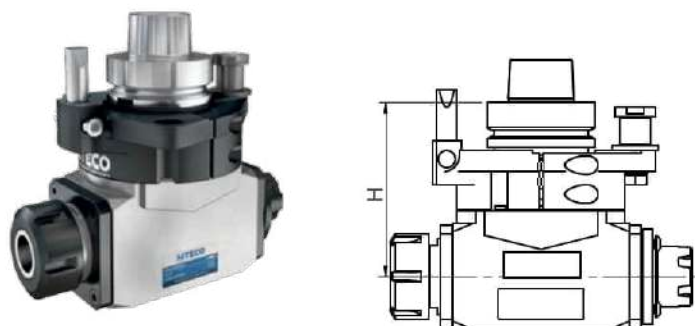

Dvojevýstupový pevný agregát pre stopkové nástroje (frézy, dlabacie vŕtáky, vŕtáky). Dodáva sa v troch dĺžkových variantoch. Upinanie agregátu sa definuje podľa konkrétneho typu stroja.

TWIN PRO

	cena od 2 000,-€
H	162
n_{max} vstup	6 800
n_{max} výstup	18 000
D1 RH	2-16 (ER25)
D1 LH	2-16 (ER25)
mazanie	plastické mazivo

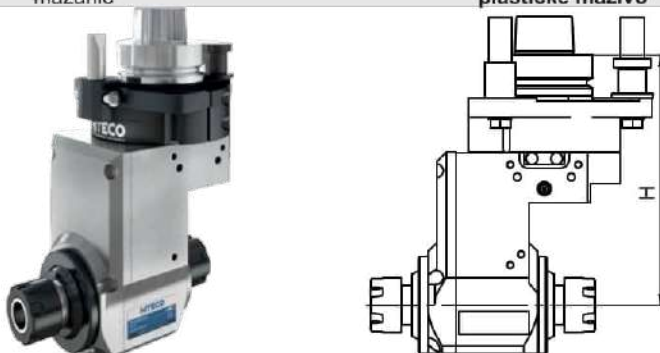

Dvojevýstupový, asymetrický pevný agregát pre stopkové nástroje (frézy, dlabacie vŕtáky, vŕtáky). Asymetrické usporiadanie umožňuje lepšie využiť pracovný priestor stroja, najmä pri menších strojoch. Upinanie agregátu sa definuje podľa konkrétneho typu stroja.

MULTIBLADE

	cena od 2 000,-€
H	100/145/180
n_{max} vstup	15 500
n_{max} výstup	10 850
D	30
D _{max}	240 (pre H=180)
mazanie	plastické mazivo



Jednovýstupový pevný agregát pre frézy, drážkovacie kotúče a pilové kotúče. Pri osadzovaní frézovacieho nástroja je treba dbať na dodržanie maximálnej hmotnosti celej jednotky pre konkrétny typ stroja. Dodáva sa v troch dĺžkových variantoch. Upinanie agregátu sa definuje podľa konkrétneho typu stroja.

NOTCH FRESA

	cena od 2 000,-€
H	180
n_{max} vstup	6 000
n_{max} výstup	13 000
D	16 + 4xM5
D _{max}	150
mazanie	plastické mazivo

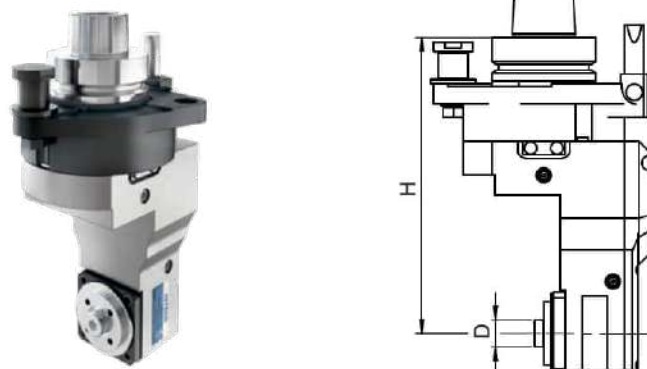

Jednovýstupový pevný agregát pre frézy a drážkovacie kotúče. Určený predovšetkým na dokončovanie ostrých rohov pri otvoroch pre sklo a výplne dverí a dvierok. Upinanie agregátu sa definuje podľa konkrétneho typu stroja.

VÁKUOVÉ PRÍSAVKY A UPINÁKY

Na všetky frekventované typy CNC strojov vybraných výrobcov máme spoľahlivé riešenie vákuového upínania obrobku. Vákuové prísvky dodávame vo dvoch konštrukčných vyhotoveniach **A**, **B**.



A- (zložené) základňa + päťka.
Toto riešenie umožňuje na univerzálnu základňu konkrétneho typu stroja osadiť päťku v rôznych rozmerových a tvarových variantoch.
Nízka cena samotnej päťky, šírka sortimentu a rýchle nasadenie sú oceňované predovšetkým v zákazkovej výrobe.

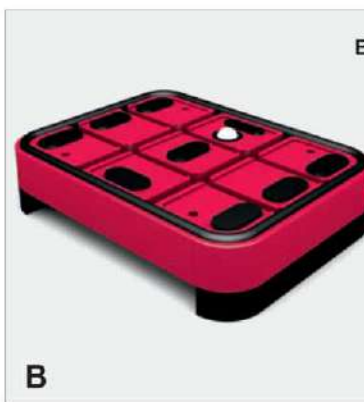

B- (samostatné) compact.
Prísvka je obvyklé tradičné riešenie, obľúbené pre nízku obstarávaciu cenu a spoľahlivosť. Limitom je obmedzený sortiment tvarov a rozmerov.

VACUUM BLOCK BS01

scmgroup morbidelli

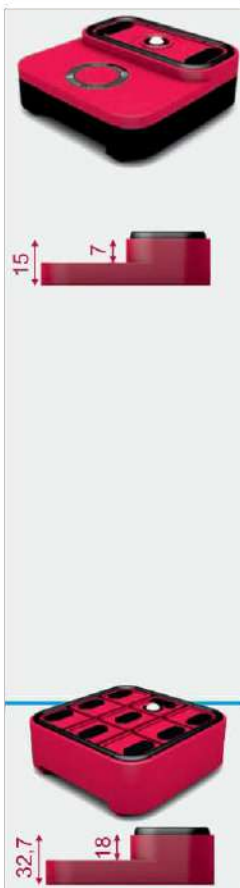

ZÁKLADŇA

120x120	
237BS01N	102,-€

PÄTKA

120x120		120x100		120x80		120x70	
237CA12015T	78,-€	237CA10015T	78,-€	237CA08015N	78,-€	237CA07015N	78,-€
120x60		120x50		120x40		120x35	
237CA06015N	78,-€	237CA05015N	78,-€	237CA04015N	78,-€	237CA03515N	78,-€
120x30		120x50		120x40			
237CA03015N	78,-€	237CA05015D	78,-€	237CA05015L	84,-€		

COMPACT

120x100		120x80		120x70	
237KA01-12032T	108,-€	237KA01-07032T	108,-€	237KA01-06032T	108,-€

VACUUM BLOCK BS05

scmgroup morbidelli



ZÁKLADŇA

145x145	
237BS05N	132,-€

PÄTKA

145x145		145x100		145x80		145x70	
237CC14530T	90,-€	237CC10030T	90,-€	237CC08030N	90,-€	237CC07030N	90,-€
145x60		145x50		145x40		145x35	
237CA06030N	83,-€	237CC05030N	90,-€	237CC04030N	90,-€	237CC03530N	90,-€



ZÁKLADŇA

158x120



237BS03N 126,-€



PÄTKA

158x120



237CB12015T 84,-€

158x100



237CB10015T 84,-€

158x80



237CB08015N 84,-€

158x70



237CB07015N 84,-€

158x60



237CB06015N 84,-€

158x50



237CB05015N 84,-€

158x40



237CB04015N 84,-€

158x35



237CB03515N 84,-€

158x30



237CB03015N 84,-€



COMPACT

158x120



237KB03-12021T 132,-€

158x70



237KB03-07021T 132,-€

158x60



237KB03-06021T 132,-€



ZÁKLADŇA

158x120



237BS08N 135,-€



PÄTKA

158x120



237CB12015T 84,-€

158x100



237CB10015T 84,-€

158x80



237CB08015N 84,-€

158x70



237CB07015N 84,-€

158x60



237CB06015N 84,-€

158x50



237CB05015N 84,-€

158x40



237CB04015N 84,-€

158x35



237CB03515N 84,-€

158x30



237CB03015N 84,-€

158x80



237CB05015L 90,-€

COMPACT

158x120



237KB08-12035T 132,-€

158x70



237KB08-07035N 132,-€

158x60



237KB08-06035N 132,-€





ZÁKLADŇA

145x145		145x145	
237BS28N20	168,-€	237BS28G20	192,-€

PÄTKA

145x145		145x100		145x80		145x70	
237CC14530T	90,-€	237CC10030T	90,-€	237CC08030N	90,-€	237CC07030N	90,-€
158x60		158x50		158x40		158x35	
237CC06030N	90,-€	237CC05030N	90,-€	237CC04030N	90,-€	237CC03530N	110,-€

COMPACT

145x145		145x100		145x80		145x70	
237CC14555T	144,-€	237CC10055T	144,-€	237CC08055N	144,-€	237CC07055N	144,-€
145x60		145x50		145x40		145x35	
237CC06055N	144,-€	237CC05055N	144,-€	237CC04055N	144,-€	237CC03555N	156,-€



VACUUM BLOCK BS13



ZÁKLADŇA

120x158x30		120x158x40		120x158x51	
237BS13N30	126,-€	237BS13N40	138,-€	237BS13N51	153,-€

PÄTKA

120x158		120x100		120x80		120x70	
237CV15820T	87,-€	237CV10020T	87,-€	237CV08020N	87,-€	237CV07020N	87,-€
120x60		120x50		120x40			
237CV06020N	87,-€	237CV05020N	87,-€	237CV04020N	87,-€		
158x120		158x100		158x80		158x70	
237CB12020T	87,-€	237CB10020T	87,-€	237CB08020N	87,-€	237CB07020N	87,-€
158x60		158x50		158x40			
237CB06020N	87,-€	237CB05020N	87,-€	237CB04020N	87,-€		
120x158		120x120		120x100		120x80	
237CM15860T	95,-€	237CM12060T	95,-€	237CM10060T	95,-€	237CM08060N	95,-€
120x70		120x60		120x50		120x40	
237CM07060N	95,-€	237CM06060N	95,-€	237CM05060N	95,-€	237CM04060N	95,-€





ZÁKLADŇA

120x158x40



237BS17N40 120,-€

120x158x25



237BS17N-25 108,-€

120x158x51



237BS17N-51 137,-€

PÄTKA

120x158



237CM15860T 95,-€

120x120



237CM12060T 95,-€

120x100



237CM10060T 95,-€

120x80



237CM08060N 95,-€

120x70



237CM07060N 95,-€

120x60



237CM06060N 95,-€

120x50



237CM05060N 95,-€

120x40



237CM04060N 95,-€



120x158



237CV15825T 90,-€

120x70



237CV07025N 90,-€

120x60



237CV06025N 90,-€

158x120



237CB12025T 92,-€

158x70



237CB07025N 92,-€

158x60



237CB06025N 92,-€



ZÁKLADŇA

120x158x40



237BS18N40 120,-€

120x158x25



237BS18N25 108,-€

120x158x51



237BS18N51 137,-€

PÄTKA

120x158



237CM15860T 95,-€

120x120



237CM12060T 95,-€

120x100



237CM10060T 95,-€

120x80



237CM08060N 95,-€

120x70



237CM07060N 95,-€

120x60



237CM06060N 95,-€

120x50



237CM05060N 95,-€

120x40



237CM04060N 95,-€



120x158



237CV15825T 90,-€

120x70



237CV07025N 90,-€

120x60



237CV06025N 90,-€

158x120



237CB12025T 90,-€

158x70



237CB07025N 92,-€

158x60



237CB06025N 92,-€





ZÁKLADŇA		HC HOMAG masterwood
120x120x7		
237BS16H	108,-€	

ZÁKLADŇA		scm morbidelli
120x120x6		
237BS16N	108,-€	



PÄTKA			
120x120		120x100	
237CA12030T	83,-€	237CA10030T	83,-€
120x80		120x70	
237CA08030N	83,-€	237CA07030N	83,-€
120x60		120x50	
237CA06030N	83,-€	237CA05030N	83,-€
120x40		120x35	
237CA04030N	83,-€	237CA03530N	83,-€
120x30		120x50	
237CA03030N	83,-€	237CA05030D	95,-€
		120x50	
		237CA05030L	90,-€
		120x120	
		237CA12030P	132,-€



COMPACT			
120x120		120x70	
237KA16-12025T	108,-€	237KA16-07025N	108,-€
		120x60	
		237KA16-06025N	108,-€



120x60		120x50	
237CA06030N	83,-€	237CA05030N	83,-€
		120x40	
		237CA04030N	83,-€



LIFTERS			
120x120x10		120x120x20	
237EA12010N	na dopyt	237EA12020N	na dopyt
		120x120x30	
		237EA12030N	na dopyt

VACUUM BLOCK KG10

BIESSE



COMPACT			
132x132		132x100	
237KG10-13229T	96,-€	237KG10-10029T	96,-€
132x80		132x70	
237KG10-08029N	96,-€	237KG10-07029N	96,-€
132x60		132x50	
237KG10-06029N	96,-€	237KG10-05029N	96,-€
132x40		132x35	
237KG10-04029N	96,-€	237KG10-03529N	96,-€



BOTTOM RING	
	RINGB na dopyt



VACUUM BLOCK KF12

BIESSE



COMPACT

132x145x29

237KF12-14529T *na dopyt*

132x100

237KF12-10029T *na dopyt*

132x80

237KF12-08029N *na dopyt*

132x70

237KF12-07029N *na dopyt*

132x60

237KF12-06029N *na dopyt*

132x50

237KF12-05029N *na dopyt*

132x40

237KF12-04029N *na dopyt*

132x35

237KF12-03529N *na dopyt*

VACUUM BLOCK KF12

BIESSE

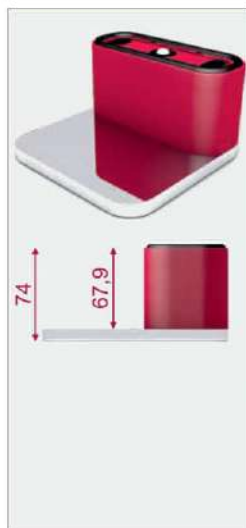

COMPACT

132x145



237KF12-14574T 125,-€

132x100



237KF12-10074T 125,-€

132x80



237KF12-08074N 125,-€

132x70



237KF12-07074N 125,-€

132x60



237KF12-06074N 125,-€

132x50



237KF12-05074N 125,-€

132x40



237KF12-04074N 125,-€

132x35



237KF12-03574N 125,-€

Bottom Crown Biesse

*na dopyt*

Aluminium Plate

*na dopyt*

VACUUM BLOCK BS15

BIESSE

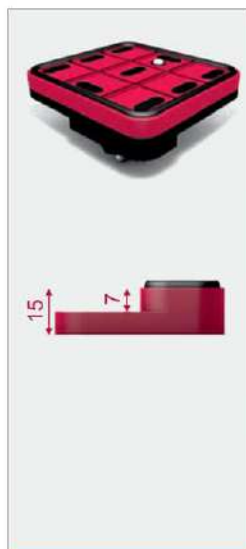

ZÁKLADŇA

120x158x40



237BS17N40 120,-€

PÄTKA

160x150



237CL15015T 90,-€

160x100



237CL10015T 90,-€

160x80



237CL08015N 90,-€

160x70



237CL07015N 90,-€

160x60



237CL06015N 90,-€

160x50



237CL05015N 90,-€

160x40



237CL04015N 90,-€

COMPACT

160x150



237KL15-15024T 126,-€

132x100

*na dopyt*



ZÁKLADŇA

132x132x30	
237BS27N-30	113,-€

PÄTKA

132x132	
237CG13230T	90,-€

132x100	
237CG10030T	90,-€

132x80	
237CG08030N	90,-€

132x70	
237CG07030N	90,-€

132x60	
237CG06030N	90,-€

132x50	
237CG05030N	90,-€

132x40	
237CG04030N	90,-€

132x35	
237CG03530N	96,-€

132x132	
237CG13230P	162,-€



MECHANICAL CLAMPERS

PRE VŠETKY STROJE



PÄTKA

120x120x32,7	
237PR132N	480,-€

120x120x50	
237PR02N	480,-€

145x145x50	
237PR05N	<i>na dopyt</i>

132x132	
x29/ 462,-€	
x48/ 519,-€	
x74/ 558,-€	
237PR10N	

158x120	
x50/ 474,-€	
x100/ 564,-€	
x125/ <i>dopyt</i>	
237PR13N	

120x120x50	
237PR16N	474,-€

158x120	
x100/ 540,-€	
x50/ 474,-€	
237PR17N	

132x132x50	
237PR27N	498,-€

145x145	
x50/ 750,-	
x75/ 750,-	
237PR28N	

NESTING MODUL

PRE VŠETKY STROJE



nesting modul	rozmer 910x680x30	Nr 237MMN	€ 595,-

Zložením rastrovaných modulárných segmentov si vytvoríte na svojom stroji nestingový vákuový stôl.

Jeden modul je fixovaný cez štyri upínacie základne. Moduly je možné napájať v násobkoch 910x680mm do požadovaného rozmeru stola. Toto riešenie prináša veľkú variabilitu upínania a rozširuje tak výrobné možnosti stroja.

System je obľúbený pre jeho jednoduché a rýchle inštalovanie, ako i zameniteľnosť medzi rôznymi typmi strojov.

VÁKUOVÉ GUMY

PRE VŠETKY STROJE



tvár	rozмеры (mm)	Nr	€
	ø 8	237GO-Di-8	3,50
	ø 7	237GO-Di-7	3,25
	ø 6	237GO-Di-6	3,00
	ø 5	237GO-Di-5	2,75
	ø 4	237GO-Di-4	2,75
	ø 3	237GO-Di-3	2,75
	9x6	237GO-VA-9x6	3,50

Gumové profily sú vyhotovené zo špeciálneho materiálu určeného výlučne pre vákuové upínacie systémy.

PLASTOVÁ T UPÍNKA

plastová T upínka	Nr 617A91349	€ 9,50
-------------------	-----------------	-----------



Upínka pre stoly s T drážkou s veľkým hrúbkovým rozsahom obrobku. Plastové telo minimalizuje riziko poškodenia nástroja pri kolízii s upínkou.

HLINÍKOVÁ T UPÍNKA

hliníková T upínka	Nr 617A91353	€ 19,20
--------------------	-----------------	------------



Upínka v hliníkovom vyhotovení pre stoly s T drážkou. "Plytký" profil upínky a jej predĺžené vyloženie s pogumovanými koncami sú výhodou pre tuhé upnutie obrobku.

SKRUTKOVÁ UPÍNKA

skrutková upínka 1ks	Nr 617A91362	€ 24,30
----------------------	-----------------	------------

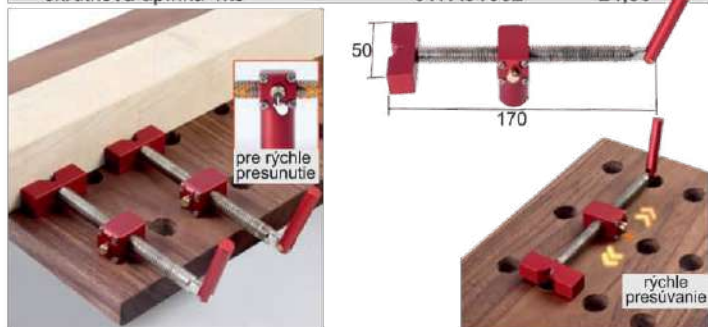

Upínka pre dierované / 20mm/ stoly je určená pre zvlášť tuhé upnutie obrobku. Pre rýchle nastavenie upínania je vybavená „odomykacím“ mechanizmom.

T PROFIL S BEŽCOM

lišta L=400mm	balenie 1ks	Nr 617A91355	€ 11,20
bežec	10ks	617A91356	2,30

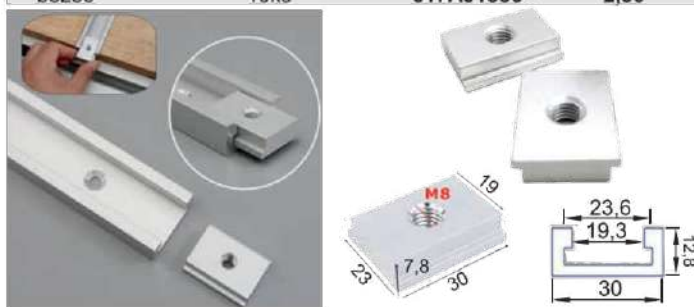

Hliníková lišta v tvare T je určená pre vytvorenie upínacieho prostredia. Bežec odpovedajúceho profilu so závitom M8 je použiteľný pre rôzne aplikácie.

PRUŽINOVÁ UPÍNKA

pružinová upínka 1ks	Nr 617A91358	€ 12,10
----------------------	-----------------	------------



Hliníková upínka je určená pre T stoly. Je vybavená pružinou pre pohodlné a rýchle ustavovanie

UNIVERZÁLNA UPÍNKA

univerzálna upínka 1ks	Nr 617A91336	€ 18,50
------------------------	-----------------	------------



Robustná upínka z hliníka umožňuje jej použitie v dierovaných aj v T stoloch. Je vybavená pružinou pre rýchle a pohodlné ustavovanie.

SKRUTKA POLYAMID

d	L	balenie	Nr	€
5	16	10 ks	304963050016	1,83
5	25	10 ks	304963050025	3,33
8	30	10 ks	304963080030	5,42
8	40	10 ks	304963080040	7,08
8	50	10 ks	304963080050	8,08

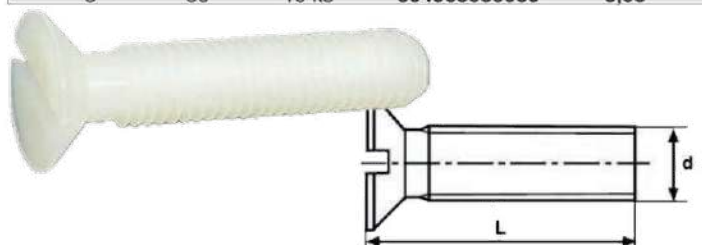

Polyamidové skrutky s metrickým závitom sa s výhodou používajú pri výrobe upínacích šablón. Plastové vyhotovenie skrutky znižuje riziko poškodenia nástroja pri neželanom kontakte.

TAPE CNC

šírka	L	Nr	€
12 mm	3m	3502006000000	2,33
18 mm	3m	3502006000010	3,25

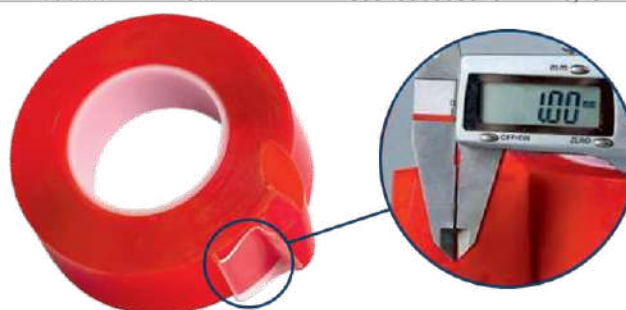

Obojstranná akrylová páska s vysokou lepiivosťou je vhodná pre fixovanie obrobku na podložku jeho prilepením.

OBSAH

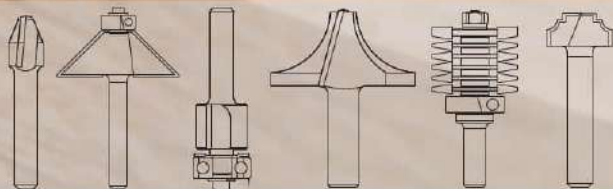

STOPKOVÉ FRÉZY



eshop.woodb.sk



STROJE

NÁSTROJE

NÁRADIE

KOVANIE

CHÉMIA

SPOJOVACÍ MATERIAL

DIELŇA

DOM-ZÁHRADA

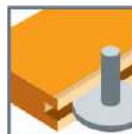

Drážkovacie kotúčové frézy

8.3



Výplňové a rámové frézy

8.16

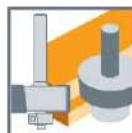

Orezávacie a falcovacie frézy

8.3

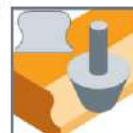

Madlové frézy

8.15



Frézy na spoje a rybiny

8.6

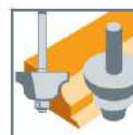

Profilové frézy

8.10 , 8.13 , 8.15

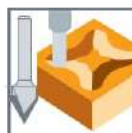

Gravírovacie frézy

8.4



Frézy na okná

8.20

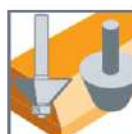

Uhlové frézy

8.5

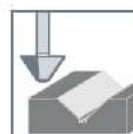

Frézy Corian

8.14

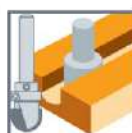

Žliabkové frézy

8.6



Frézy na olepené hrany

9.3



Frézy na Alucobond

8.4

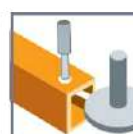

Frézy na hliník

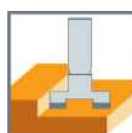

Frézy zrovnávacie plošné

6.8

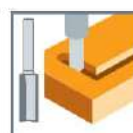

Frézy drážkovacie

8.1

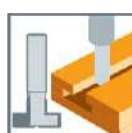

Frézy na tvarové drážky

8.8 , 8.17



Príslušenstvo

8.23

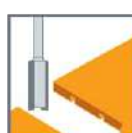

Frézy na pracovné dosky

6.5 , 8.22



Sady stopkových fréz

Za 24 hod.
doručíme každú
frézu



Zaobľovacie frézy

8.7

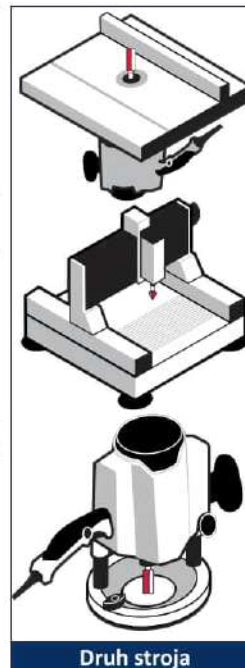
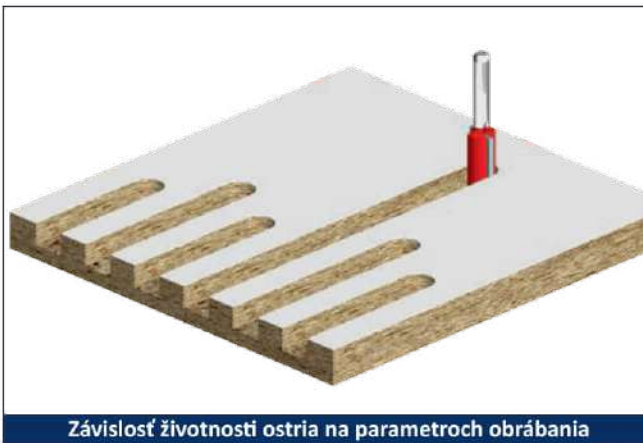
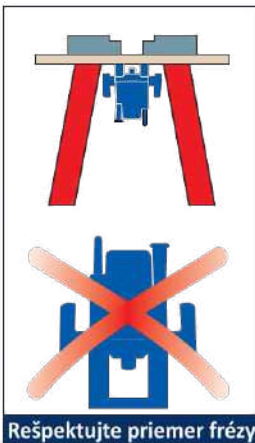
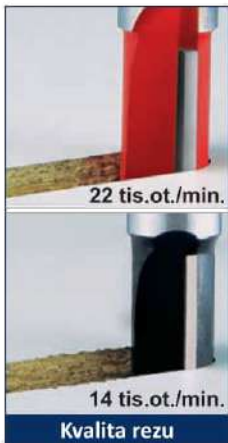

priemer nástroja / hornej frézy				max. otáčky !!!!!		
od	2 mm	5/64"	do	29 mm	1-9/64"	24.000
	30 mm	1-3/16"		43 mm	1-11/16"	20.000
	44 mm	1-47/64"		50 mm	1-31/32"	18.000
	51 mm	2-1/64"		69 mm	2-23/32"	16.000
	70 mm	2-3/4"		89 mm	3-1/2"	12.000

Závislosť priemeru nástroja na doporučených otáčkach

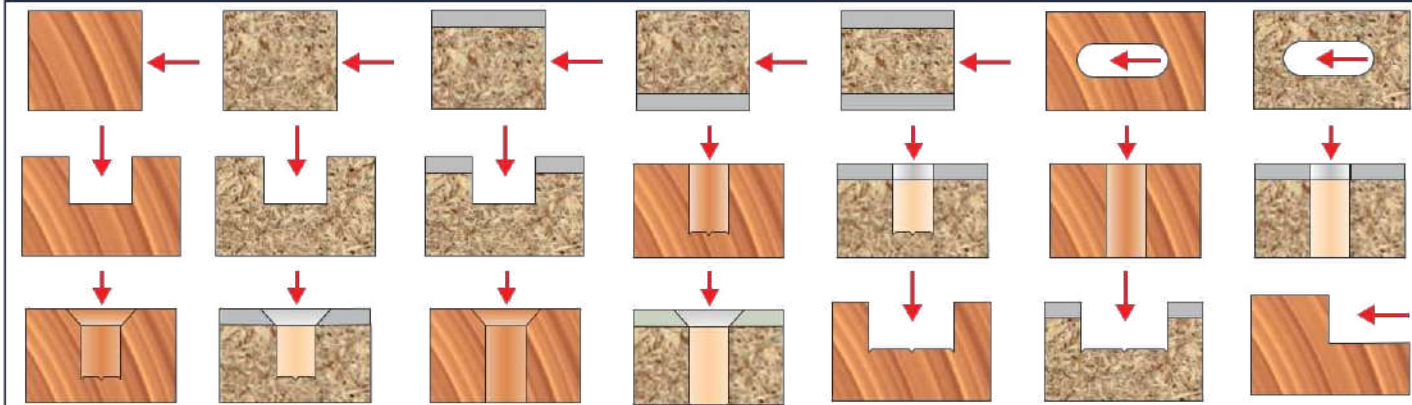
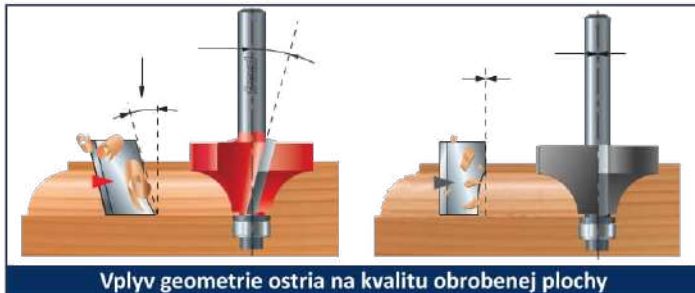
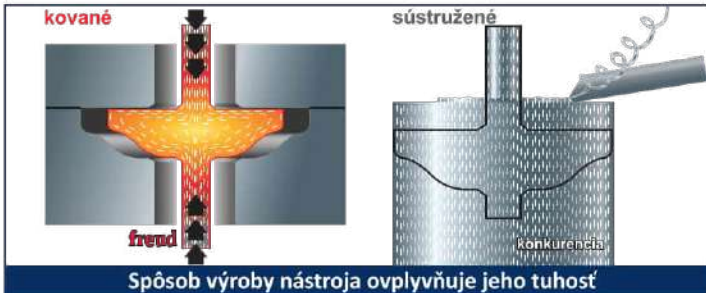
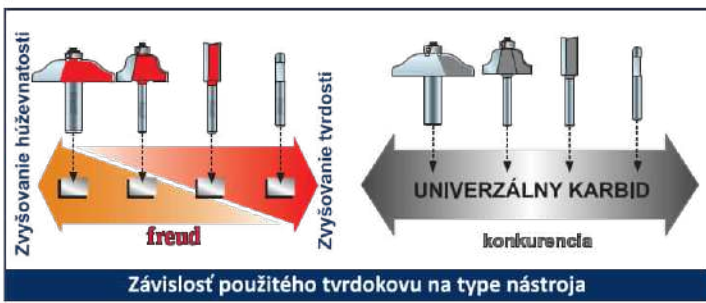



191 ; 192		DRAŽKOVACIE FRÉZY ŠPIRÁLOVÉ Z=2+2		Klein HW	MAN		
ø D	B	L	ø d	Nr POZITIV	€	Nr NEGATIV	€
3	12	60	8	231.191.830.11	20,70	231.192.830.11	23,80
4	14	60	8	231.191.840.11	23,80	231.192.840.11	23,80
5	17	60	8	231.191.850.11	25,00	231.192.850.11	25,00
6	22	70	8	231.191.860.11	26,40	231.192.860.11	26,40
7	32	80	8	231.191.870.11	30,00	231.192.870.11	30,00
8	22	80	8	231.91P.080.11	25,20	231.91N.080.11	25,20
8	35	80	8	231.91P.081.11	27,90	231.91N.081.11	27,90
12	35	80	12	231.91P.120.11	73,60	231.91N.120.11	73,60
12	45	100	12	231.91P.121.11	58,60	231.91N.121.11	58,50

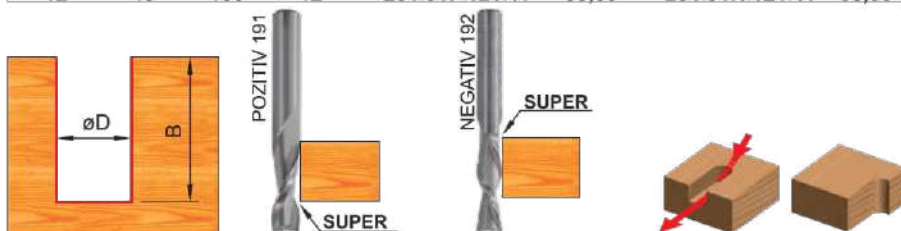

04-11		Z=2+2		DRAŽKOVACIE FRÉZY MONOLITICKÉ		freud HW	MAN
ø D	B	L	ø d	Nr	€		
2	6,3	44,5	6	2800409706	21,00		
3	9,5	44,5	6	2800409906	21,20		
4	15,8	44,5	6	2800410106	21,00		
6	16	50,8	6	2800411406	21,30		
3	9,5	44,5	8	2800409908	23,00		
4	15,8	44,5	8	2800410108	27,20		
5	12,7	50,8	8	2800411308	23,60		
6	16	50,8	8	2800411408	25,30		
6	25,4	60	8	2800411008	33,50		

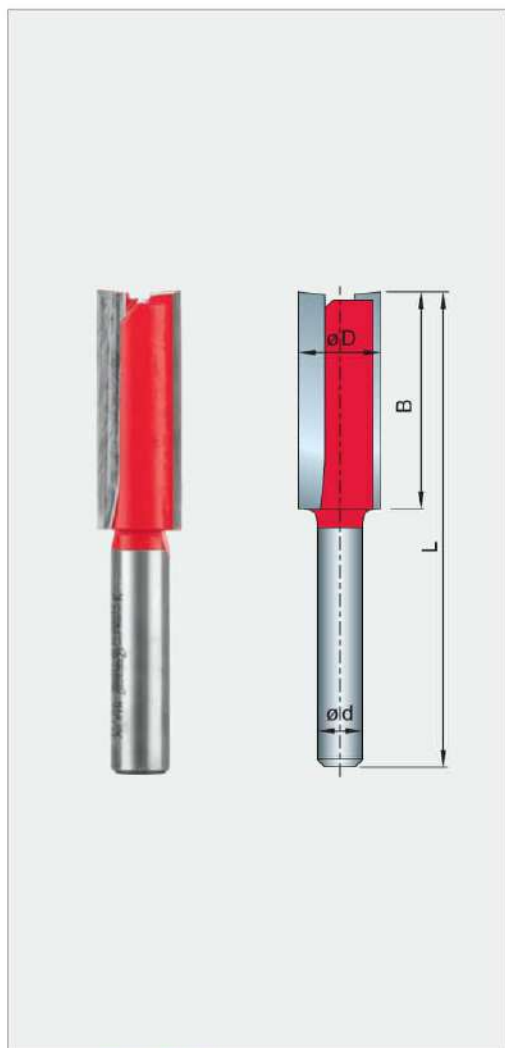

04-15		Z=2		DRAŽKOVACIE FRÉZY Z=2		freud HW	MAN
ø D	B	L	ø d	Nr	€		
8	19	52	6	2800411506	19,00		
9	25	63	6	2800412406	20,40		
10	25,4	62,4	6	280MM01006	21,00		
11	25,4	62	6	2800413306	21,05		
12	19	56	6	2800413506	21,00		
12,7 NEG	12,5	50,8	6	2801610006	16,00		
13	25	63	6	2800414206	22,10		
19	19	54	6	2800414006	21,75		
20	19	56	6	2800415506	22,60		
25	20	50	6	2800415906	29,50		
7	25,4	63,5	8	2800411208	20,80		
8	19	64	8	2800411508	19,75		
8	31,7	70	8	2800411908	21,80		
9	25	63	8	2800412408	21,25		
10	25,4	62,4	8	280MM01008	21,00		
10	31,8	69	8	280MM11008	22,50		
12	19	56	8	2800413508	20,80		
12	31,8	68	8	2800413708	22,70		
12,7 NEG	12,5	50,8	8	2801610008	16,70		
14	20	50	8	2800414308	21,85		
14	31,7	60	8	2800414508	24,15		
15	20	57,2	8	2800414608	22,05		
15	31,8	68,2	8	2800414708	24,15		
16	19	51	8	2800414908	22,40		
16	31,8	66	8	2800415008	25,00		
18	20	52	8	2800415108	22,85		
19 NEG	12,5	50,8	8	2801610408	19,10		
20	19	56	8	2800415508	23,45		
22	19	56	8	2800415708	27,45		
24	20	52	8	2800415808	30,80		
25	19	56	8	2800415908	30,30		
10	31,8	76	12	2801211212	24,00		
12	38,1	80	12	2801212212	24,30		
12	50,8	98,3	12	2801212812	25,75		
16	38,1	76,1	12	2801214012	26,95		
31,7 NEG	12,1	60,3	12	2801611812	28,75		

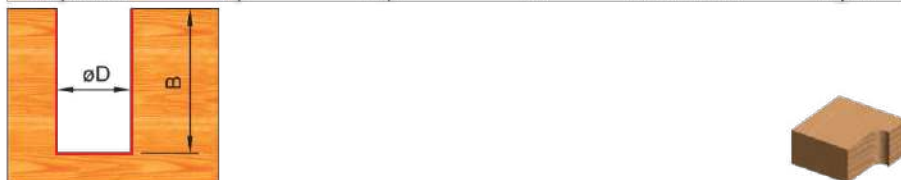

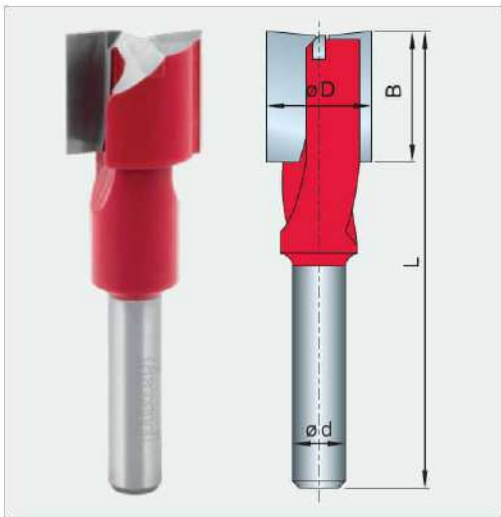

17 DŘÁŽKOVACIE ZÁVRTNÉ FRÉZY Z=2+1 **freud^{HW}**

ø D	B	L	ø d	Nr	€
16	45	85	8	2801710008	52,50
18	18	70	8	2801710208	50,25
20	18	70	8	2801710408	57,45
22	25	70	8	2801710608	50,20
16	60	110	12	2801710112	85,40
16	40	120	12	2351612012	80,50
20	40	120	12	2352012012	85,94
24	40	120	12	2352412012	96,72

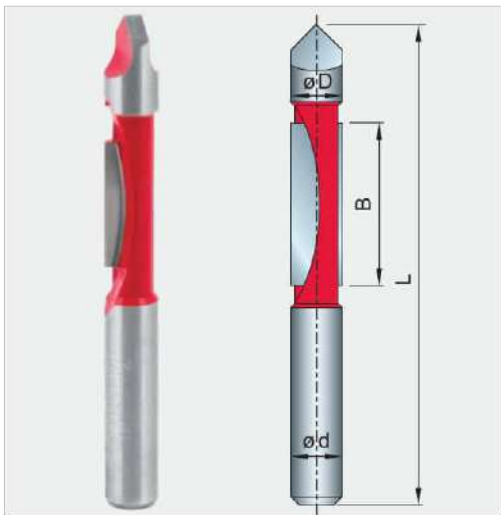
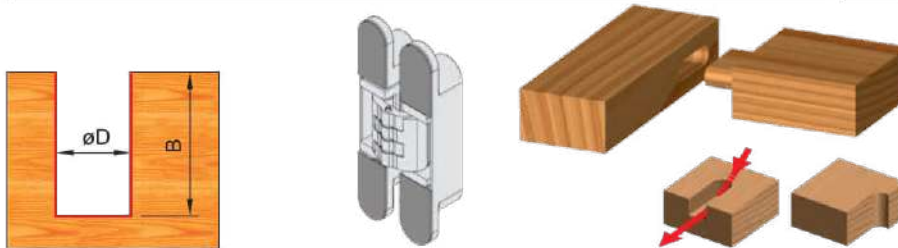

26-28 PRIEBEŽNÉ VYREZÁVACIE FRÉZY **freud^{HW}**

ø D	B	L	ø d	Nr	€
6	19	75	6	2802610006	19,40
8	19	75	8	2802610008	20,00
12,7	31,8	96,2	12	2802810412	26,20

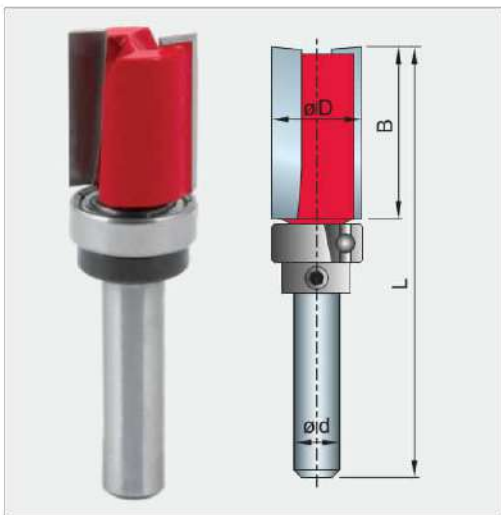
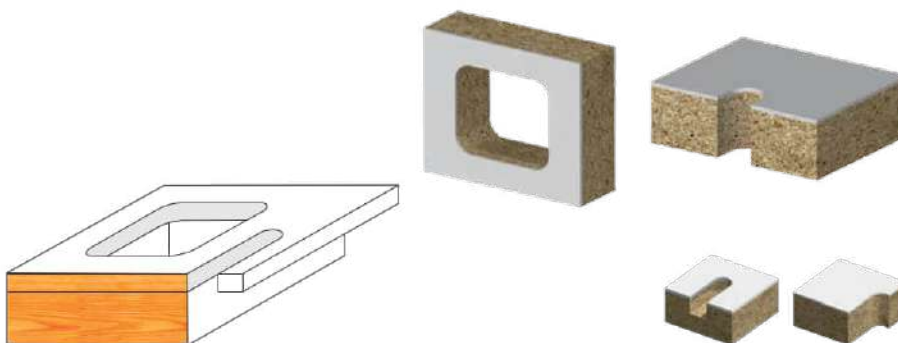

50-10 KOPIROVACIE FRÉZY S HORNÝM LOŽISKOM **freud^{HW}**

ø D	B	L	ø d	Nr	€
13	20	60	6	2805010206	29,65
15	20	60	6	2805010406	30,90
19	25,4	67,5	6	2805010606	32,00
16	20	60	8	2805010308	32,15
22	20	60	8	2805010808	33,80

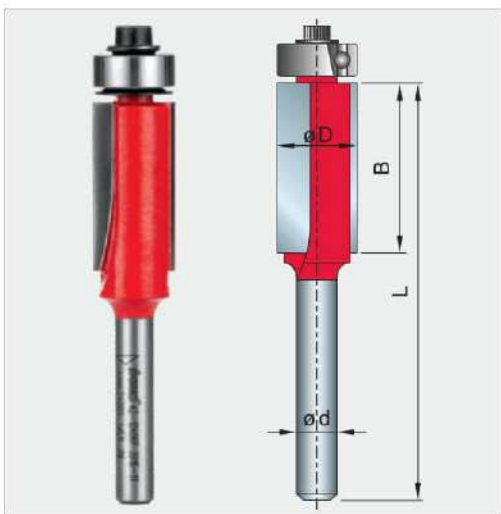
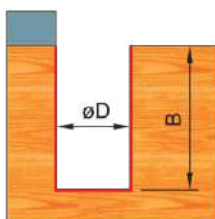

42-10 KOPIROVACIE FRÉZY SO SPODNÝM LOŽISKOM **freud^{HW}**

ø D	B	L	ø d	Nr	€
9,5	13,1	58,8	6	2804210206	18,70
12,7	25,4	71,5	6	2804210406	21,15
9,5	13,1	58,8	8	2804210208	19,30
9,5	25,4	71,5	8	2804210008	21,85
12,7	25,4	71,5	8	2804210408	22,10
12,7	40	84	8	2804211508	29,30
12,7	38,1	93,6	12	2804211412	27,40
12,7	50,8	106,8	12	2804211612	30,55

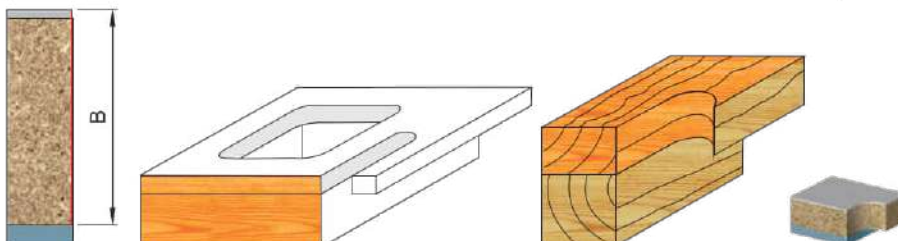



32		freud HW			FALCOVACIE FRÉZY SO SPODNÝM LOŽISKOM	
ø D	B	L	t	ø d	Nr	€
31,8	12,7	55,2	9,5	6	2803210006	25,80
31,8	12,7	55,2	9,5	8	2803210008	26,95
34,9	12,7	55,2	11,1	8	2803250008	27,90
31,8	13,2	61,7	9,5	12	2803210212	31,40
34,9	12,7	60,7	11,1	12	2803252012	32,55
NÁSTROJ SO SADOU LOŽISK						
34,9	12,7	54,7	0-12,7	8	2803250408	78,10
34,9	12,7	54,7	0-12,7	12	2803252412	87,85

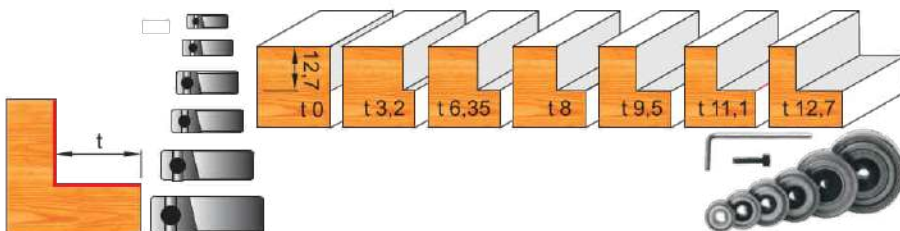

56		freud HW			DRÁŽKOVACIE FRÉZY KOTÚČOVÉ Z=3	
ø D	B	ø d	Nr	€		
50,8	1,5	8	2805609908	20,00		
50,8	1,6	8	2805610008	20,50		
50,8	1,98	8	2805610408	21,00		
50,8	2,4	8	2805610608	21,20		
50,8	2,5	8	2805611308	21,70		
50,8	3,0	8	2805611408	19,00		
50,8	3,2	8	2805610808	21,50		
50,8	3,5	8	2805611508	19,50		
50,8	3,97	8	2805610908	20,00		
50,8	4,75	8	2805611008	20,00		
50,8	5,0	8	2805611608	20,50		
50,8	5,95	8	2805611108	21,00		
50,8	6,35	8	2805611208	21,50		

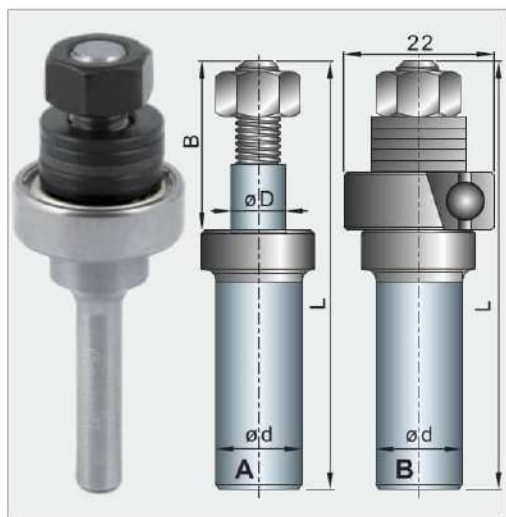

60		freud HW			UPÍNACIE TRŇE PRE KOTÚČOVÉ FRÉZY	
TYP	ø D	B	L	ø d	Nr	€
A	8	25,4	60,3	6	2806010006	9,30
B	8	25,4	60,3	6	2806012006	11,60
A	8	25,4	60,3	8	2806010008	9,40
B	8	25,4	60,3	8	2806012008	11,60
A	8	25,4	60,3	12	2806010212	10,00
B	8	25,4	60,3	12	2806012212	11,60

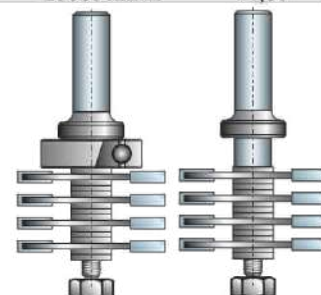
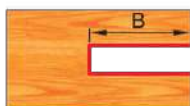

173-350		Klein HW			PLOŠNÉ ZROVNÁVACIE FRÉZY	
ø D	B	L	ø d	Z	Nr	€
41	5	46	8	4	606C173050U	60,90
52	6,5	83	12	6	606E350520R	73,70

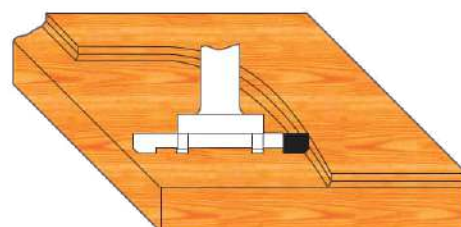

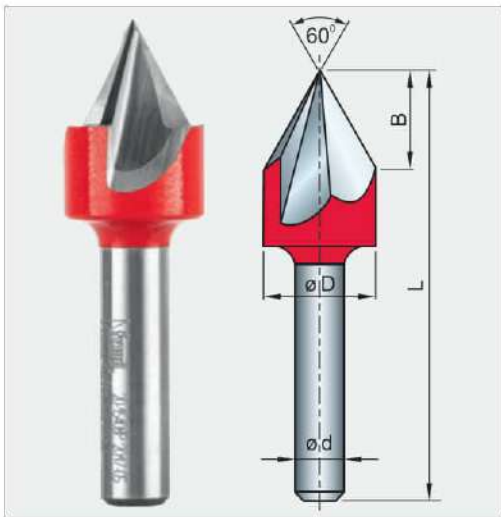

20-15 GRAVÍROVACIE FRÉZY 60° Z=3 freud^{HW}

ø D	B	L	ø d	Nr	€
12,7	11	57,3	8	2802015408	44,00

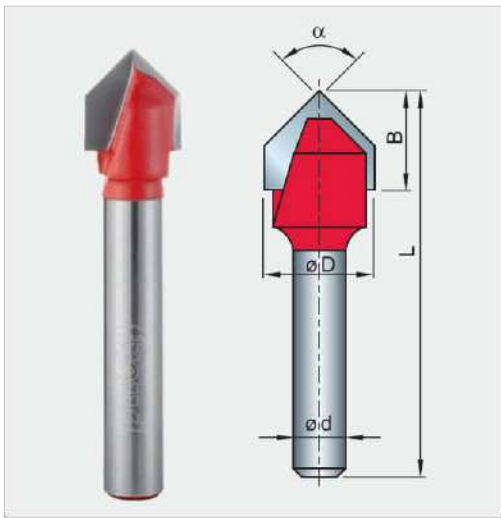
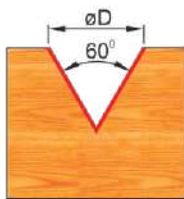

20 DRÁŽKOVACIE FRÉZY UHLOVÉ freud^{HW}

ø D	B	L	α	ø d	Nr	€
8	8	70	60°	8	2802016008	28,00
12,7	12,7	49,2	60°	8	2802015208	19,95
12,7	10	44,5	90°	6	2802010406	18,20
6	6	38,1	90°	8	2802010008	23,85
9,5	10	44,5	90°	8	2802010208	18,75
12,7	1	44,5	90°	8	2802010408	19,15
31,7	16	151	90°	8	2802091408	33,70
15,8	12,5	56,5	90°	12	2802010612	28,75
19	12,5	57,2	90°	12	2802010812	24,45

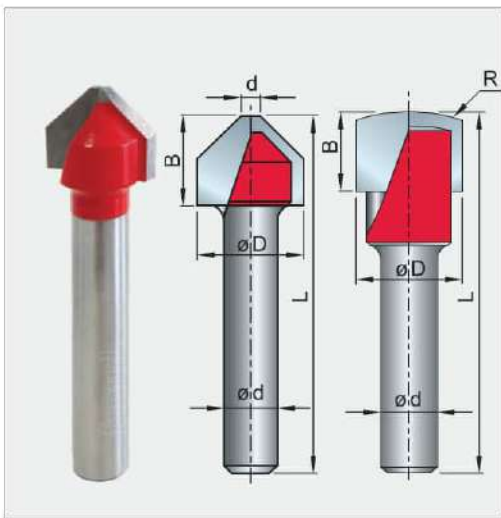
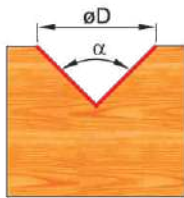

21 FRÉZY NA ALUCOBOND freud^{HW}

Profil	ø D	B	L	α	d	ø d	Nr	€
A	16	12,5	50	90°	2,5	8	2802111208	34,00
B	19	12,5	50	108°	2,5	8	2802114608	38,00
C	22,2	12,5	50	135°	2	8	2802118208	39,00
D	15	11	50	R23,8		8	2802120008	39,00

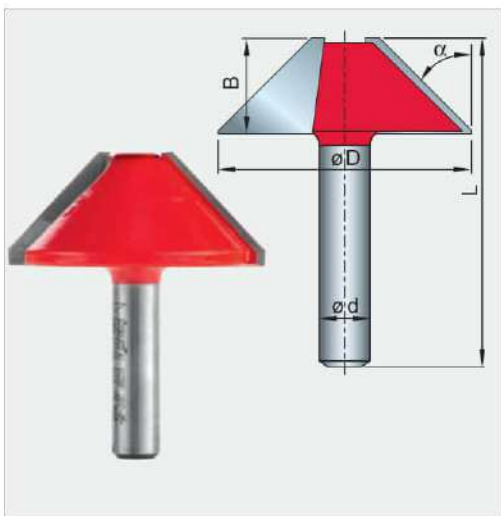
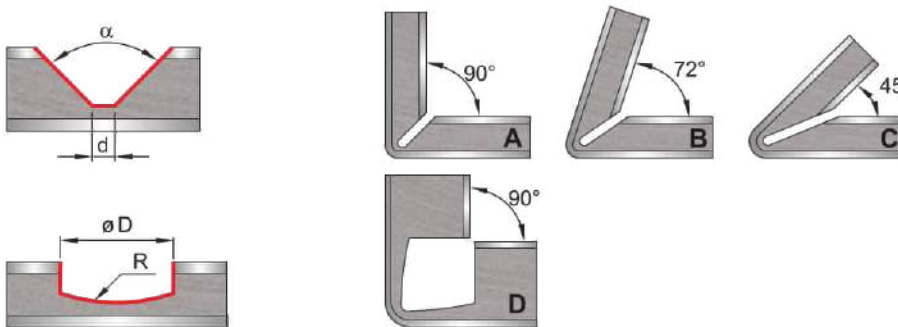

40 DRÁŽKOVACIE FRÉZY UHLOVÉ freud^{HW}

ø D	B	L	α	ø d	Nr	€
24	14	46	15°	8	2804090008	33,00
24	12	44	30°	8	2804090208	24,00
25	8	41	45°	8	2804090408	32,00

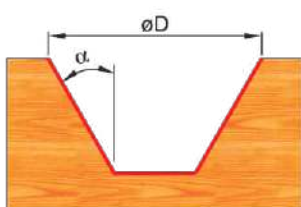

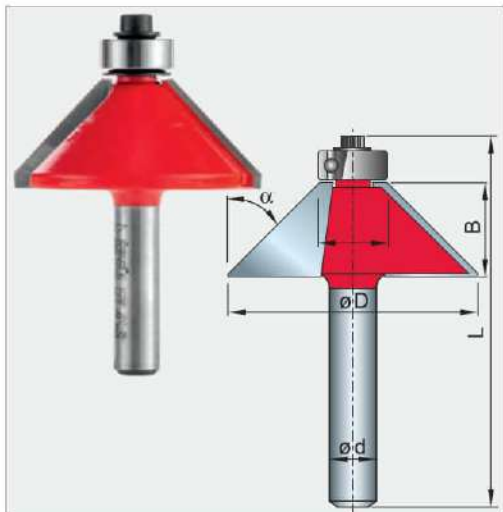

40 FRÉZY UHLOVÉ SO SPODNÝM LOŽISKOM freud^{HW}

ø D	B	L	α	ø d	Nr	€
31	9,5	52	45°	6	2804010506	28,00
18,15	12,7	54,9	15°	8	2804010008	22,70
25,4	25,4	73,7	15°	8	2804009808	38,00
23,6	12,7	54,9	25°	8	2804010208	24,00
33	19	61,6	30°	8	2804020208	39,00
31	9,5	52	45°	8	2804010508	29,00
33	11,5	54	45°	8	2804010408	27,00
44	18,5	61	45°	8	2804010608	34,00
21,8	28	73,3	11,3°	12	2804009412	37,00
25,4	25	73,3	15°	12	2804009812	41,00
30,1	22,5	70,7	22,5°	12	2804010112	41,00
44	18,5	67	45°	12	2804011412	40,00
62,1	25,5	74	45°	12	2804011812	80,00

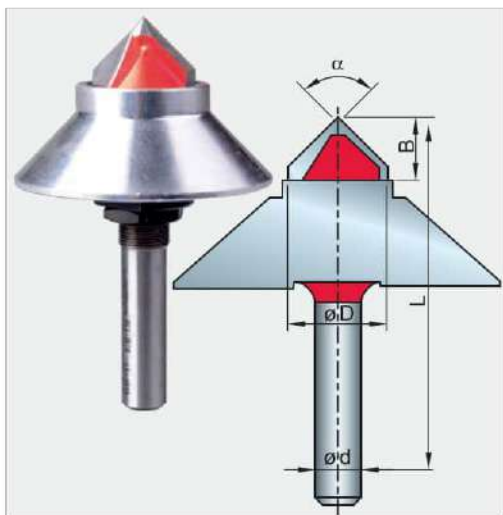
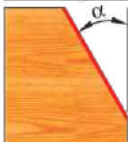

RCC UHLOVÁ KOPÍROVACIA FRÉZA trend^{HW}

ø D	B	L	ø d	Nr	€
18	12	47,6	8	302RCCX8MMTC	145,00

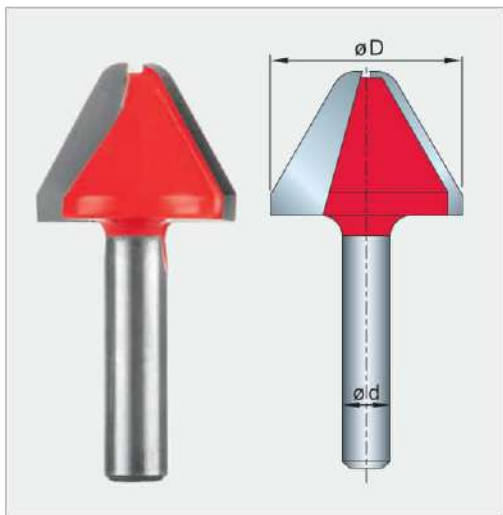
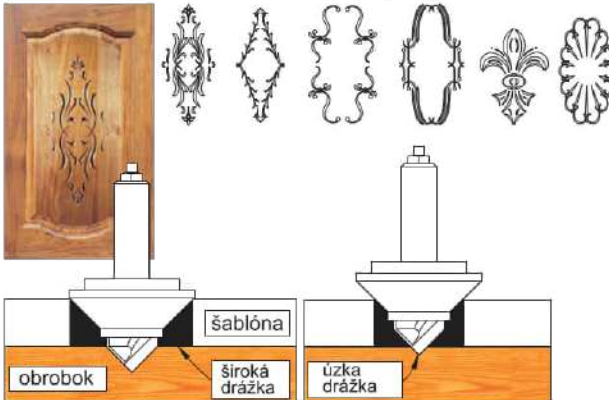

20-17 UHLOVÉ FRÉZY S ROHOVÝM RÁDIUSOM freud^{HW}

ø D	B	L	α	ø d	Nr	€
25,4	19	51	60°	6	2802017206	32,50
25,4	19	51	60°	8	2802017208	33,50
28,6	19	57	60°	12	2802017412	38,50

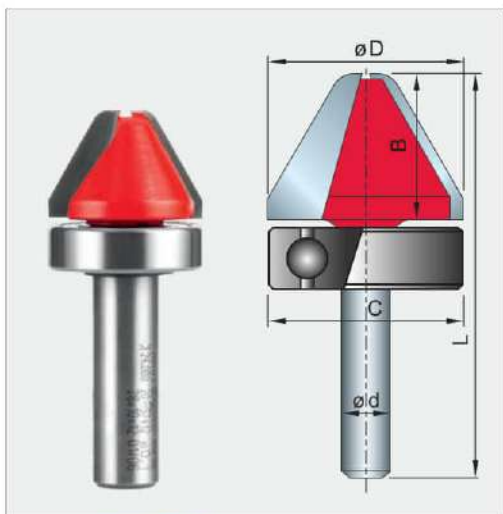
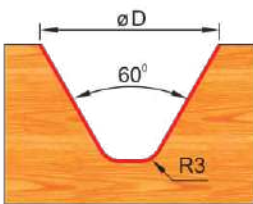

20-57 KOPÍROVACIE UHLOVÉ FRÉZY S RÁDIUSOM freud^{HW}

ø D	B	L	α	ø d	Nr	€
28,6	19	61	60°	12	2802057412	38,80

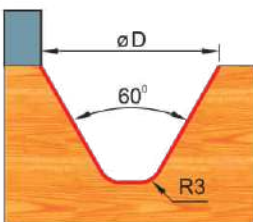

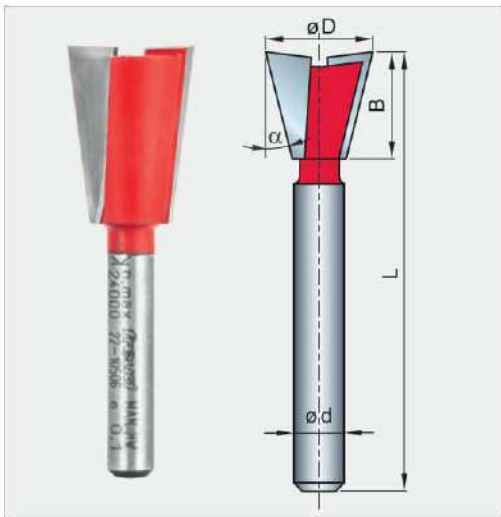

22 RYBINOVÉ FRÉZY				freud ^{HW}			
$\varnothing D$	B	L	α	$\varnothing d$	Nr	€	
12,7	12,7	47,5	14°	6	2802210406	17,45	
9,5	9,5	47,6	9°	8	2802210208	17,60	
12,7	12,7	47,5	14°	8	2802210408	18,20	
15,8	22,2	54,2	7°	8	2802210508	21,85	
19	22,2	54,2	7°	8	2802210608	22,55	
25,4	25,4	70	14°	12	606E108254R	34,20	

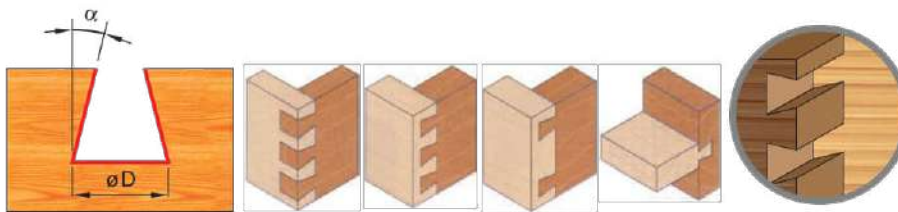

A10 RYBINOVÉ FRÉZY - HOFFMANN				Klein ^{HW}			
W	$\varnothing D$	B	L	$\varnothing d$	Nr	€	
W1	5,3	4	43	6	606A108053R	23,90	
W2	7,8	6	43	6	606A108078R	26,00	
W3	9,3	7,5	43	6	606A108093R	28,00	
W4	15,8	13	43	8	606C108161R	29,90	

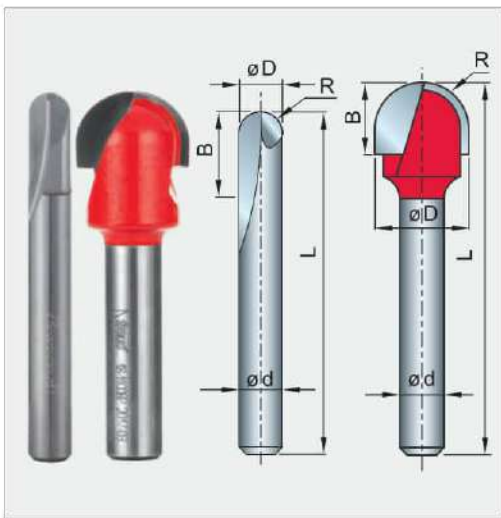
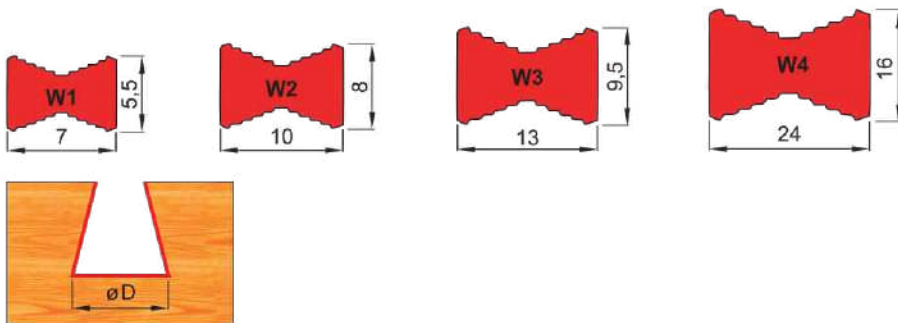

18-10 POLOKRUHOVÉ FRÉZY				freud ^{HW}			
$\varnothing D$	B	L	R	$\varnothing d$	Nr	€	
3,2	9,5	50,5	1,3	6	2801810006	24,80	
6	12,7	50,8	3	6	2801810406	27,00	
19	11	50,8	9,5	6	2801811206	21,15	
3,2	9,5	50,5	1,6	8	2801810008	28,65	
4,8	9,5	50,5	2,4	8	2801810208	28,65	
6	12,7	50,8	3	8	2801810408	29,15	
9,5	9	46	4,8	8	2801810608	17,65	
12	9	46	6	8	2801810808	18,50	
15,8	11	50,8	8	8	2801811008	19,50	
19	11	50,8	9,5	8	2801811208	21,25	
12,7	31,7	71,5	6,35	12	2801811612	27,85	
19	31,7	73	9,5	12	2801812212	31,20	
25,4	31,7	73	12,7	12	2801812612	41,75	

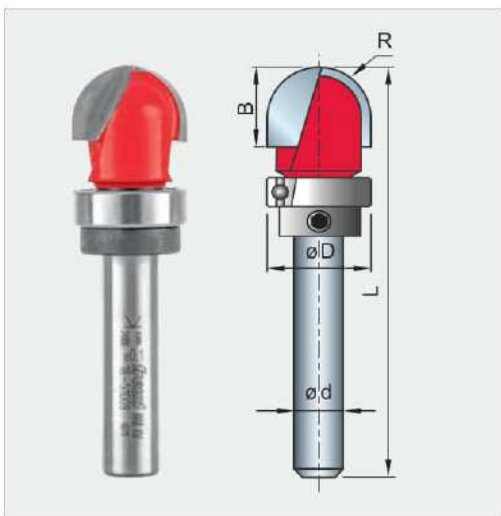
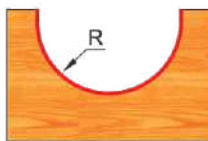

18-51 POLOKRUHOVÉ FRÉZY S HORNÝM LOŽISKOM				freud ^{HW}			
$\varnothing D$	B	L	R	$\varnothing d$	Nr	€	
19	11,1	59,5	9,5	6	2801851206	32,55	
15,8	11	59,5	8	8	2801851008	31,70	

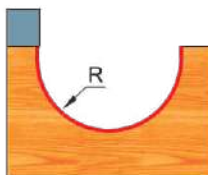

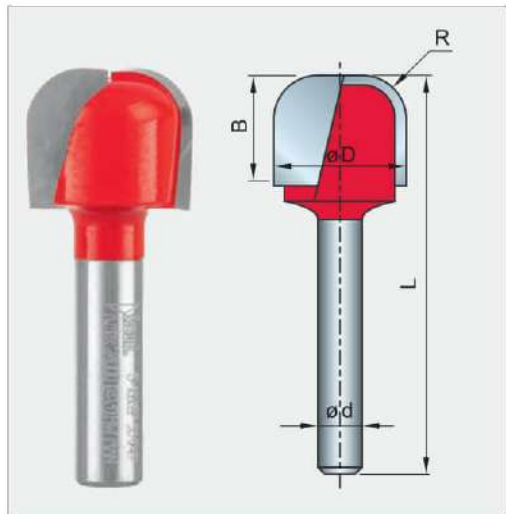

19-50		FREZY S ROHOVÝM RÁDIUSOM			freud ^{HW}			
ø D	B	L	R	ø d	Nr	€		
19	15,9	47,5	6,35	8	2801910608	31,65		
31,8	15	52,4	6,35	12	2809902612	48,50		

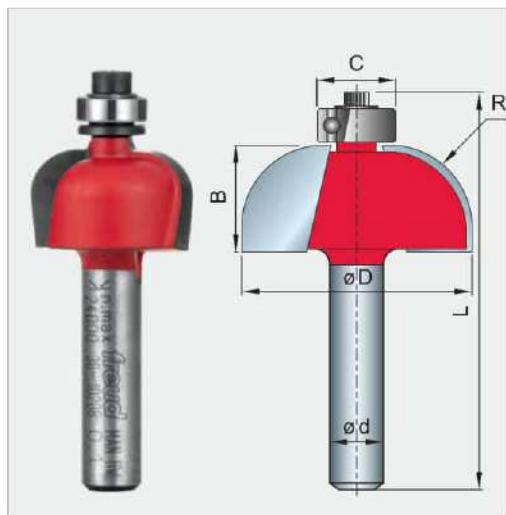
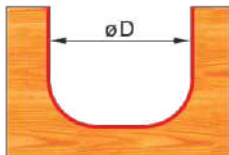

30-10		KOPIROVACIE ŠTVRŤKRUHOVÉ FRÉZY			freud ^{HW}			
ø D	B	L	R	ø d	Nr	€		
19	12,7	54,2	4,8	8	2803010008	27,80		
22,2	12,7	54,2	6,35	8	2803010208	25,20		
25,4	12,7	54,2	8	8	2803010308	30,70		
31,8	12,7	55,2	9,5	8	2803010408	26,88		
38,1	16,4	58,3	12,7	8	2803010608	31,65		

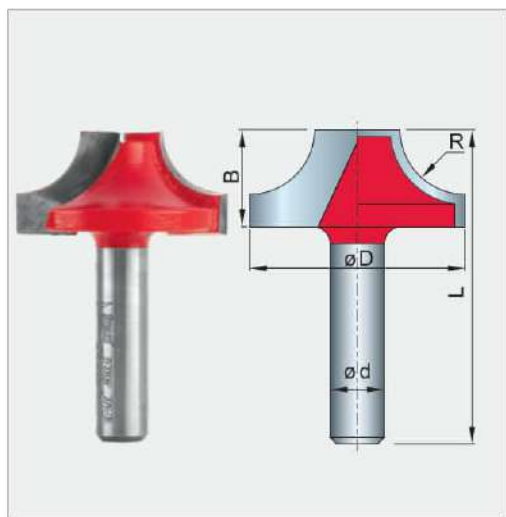
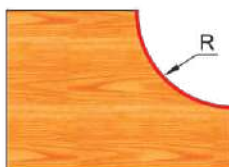

39-20		ZAOBĽOVACIE FRÉZY			freud ^{HW}			
ø D	B	L	R	ø d	Nr	€		
12,7	8	50	3,2	6	2803920206	25,70		
24,7	12,7	44,7	6	8	2803920908	31,65		
31,7	14,3	46,3	9,5	8	2803920808	34,30		
63,5	33,3	71,3	25,4	12	2803923812	79,05		

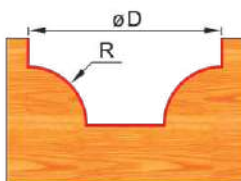

23-20		KOPIROVACIE ŠTVRŤKRUHOVÉ FRÉZY			freud ^{HW}			
Profil	ø D	B	L	R	ø d	Nr	€	
A	38	12	55,6	6,35	8	2802320008	41,80	
B	35	13,2	56,3	8	8	2802320208	40,55	
B	38	14,5	57,6	9,5	8	2802320408	43,10	

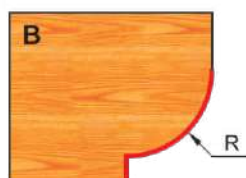
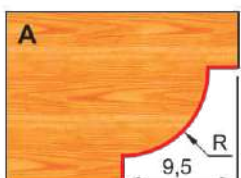



34-10 KOPÍROVACIE ZAOBĽOVACIE FRÉZY				freud ^{HW}		
ø D	B	L	R	ø d	Nr	€
15,5	12,7	54,9	1,6	6	2803410006	22,50
16,7	12,7	54,9	2	6	2803410106	24,30
19	12,7	55,2	3,2	6	2803410406	23,20
22,2	12,7	54,9	4,8	6	2803410806	22,80
25,4	12,7	55,2	6,4	6	2803411006	24,70
28,6	12,7	55,2	8	6	2803411206	26,25
38,1	19	60,7	12,7	6	2803411606	31,30
15,8	12,7	54,9	1,6	8	2803410008	23,15
16,7	12,7	54,9	2	8	2803410108	23,60
18,7	12,7	54,9	3	8	2803410308	25,75
19	12,7	55,2	3,2	8	2803410408	23,90
22,2	12,7	54,9	4,8	8	2803410808	23,20
25,4	12,7	55,2	6,4	8	2803411008	25,70
28,6	12,7	55,2	8	8	2803411208	26,80
31,8	17,5	58	9,5	8	2803411408	28,65
38,1	19,05	60,7	12,7	8	2803411608	32,35
44,5	22,2	63,9	15,8	8	2803412708	38,45
38,1	19,05	67,3	12,7	12	2803412612	39,45
50,8	25,4	73,9	19	12	2803412812	47,85
57,1	31,8	79,9	22,2	12	2803413012	78,30
63,5	31,8	79,8	25,4	12	2803413212	62,00
69,8	34,9	83,3	28,6	12	2803413412	85,70
76,2	38,1	86,6	31,8	12	2803413612	98,95

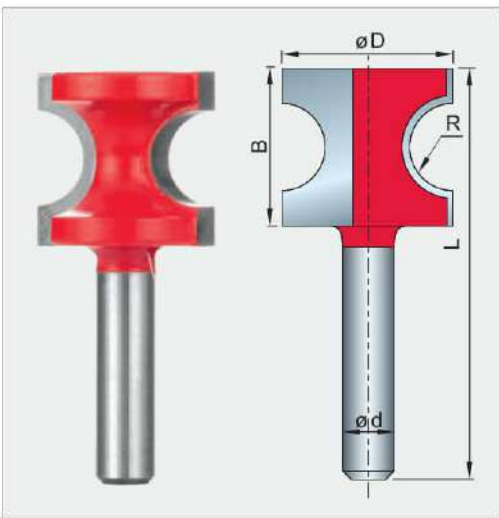
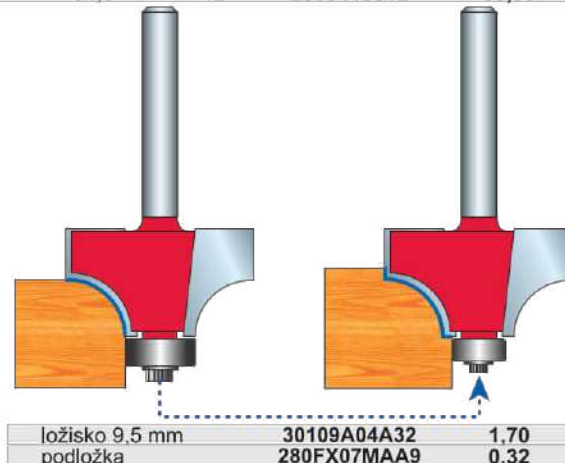
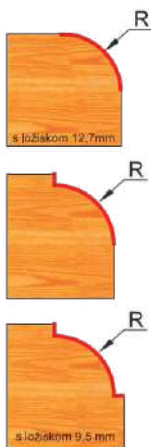

82-10 ZAOBĽOVACIE FRÉZY POLKRUHOVÉ				freud ^{HW}		
ø D	B	L	R	ø d	Nr	€
19	12,4	44,7	2	8	2808210208	25,50
22,2	19,5	51	4,8	8	2808210408	30,25
25,4	22,9	55	6,35	8	2808210608	31,30
25,4	23	65	6,35	12	2808211412	36,50
37	29	71,5	9,5	12	2808211612	41,75
45,9	35,4	73,4	12,7	12	2808211812	64,90

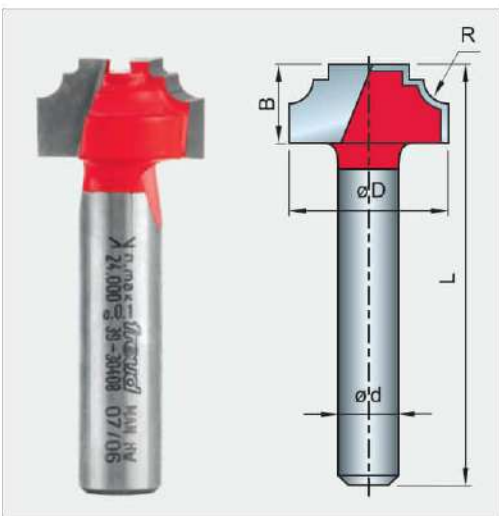

39-30 FRÉZY PRE TVAROVÉ DRÁŽKY				freud ^{HW}		
ø D	B	L	R	ø d	Nr	€
12,7	9,5	41,5	1,2	8	2803930208	24,55
15,8	9,5	41,5	2,4	8	2803930408	23,95
22,2	12	44	3,2	8	2803930608	28,80

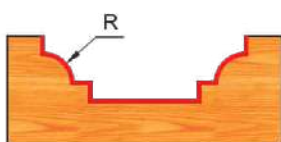

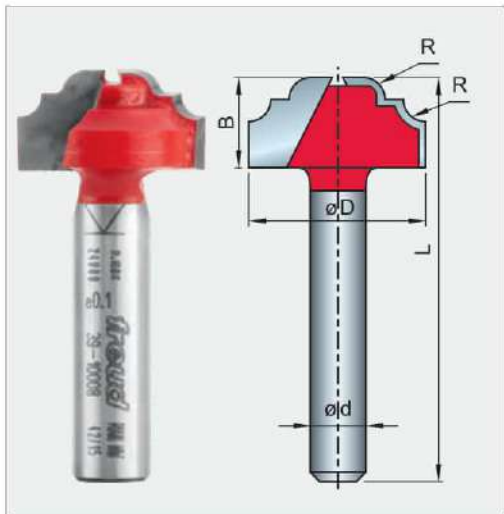

39-10 FRÉZY PRE TVAROVÉ DRÁŽKY				freud ^{HW}		
$\varnothing D$	B	L	R	$\varnothing d$	Nr	€
19	9,8	41,5	2,4	8	2803910008	26,05
19	13	45	4	8	2803910108	27,40
25,4	12,7	44,7	3,2	8	2803910208	28,00
31,8	12,7	44,7	4	8	2803911408	33,15
31,8	12,7	50,7	4	12	2803911412	40,40

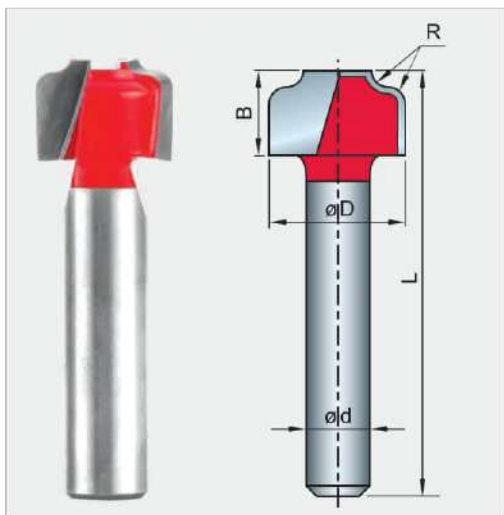
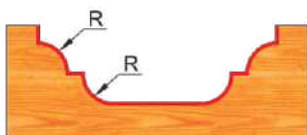

39-15 FRÉZY PRE TVAROVÉ DRÁŽKY				freud ^{HW}		
$\varnothing D$	B	L	R	$\varnothing d$	Nr	€
12,7	8	40	1,6	8	2803915208	23,95
22,2	10,4	42	3,2	8	2803915408	27,95

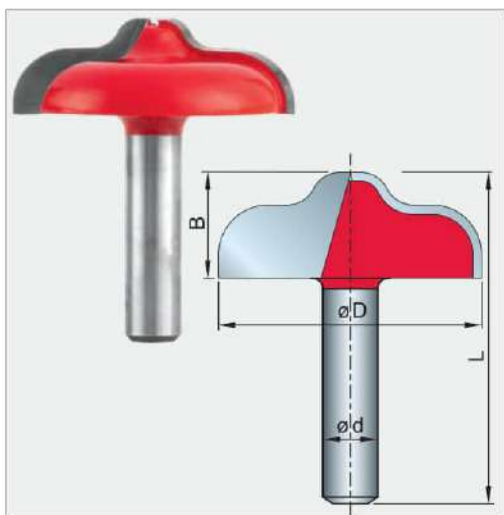
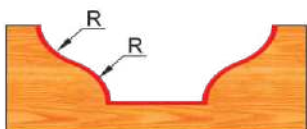

39-60 FRÉZY PRE TVAROVÉ DRÁŽKY				freud ^{HW}	
$\varnothing D$	B	L	$\varnothing d$	Nr	€
40	13	45	8	2803960008	39,05

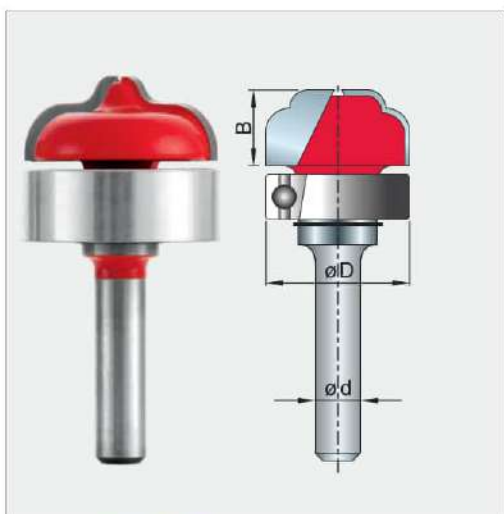
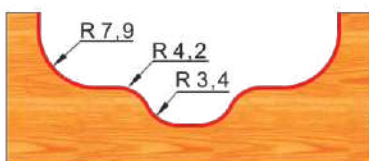

39-51 KOPIROVACIE FRÉZY PRE TVAROVÉ DRÁŽKY				freud ^{HW}	
$\varnothing D$	B	L	$\varnothing d$	Nr	€
19	9,5	53	6	2803951206	35,85

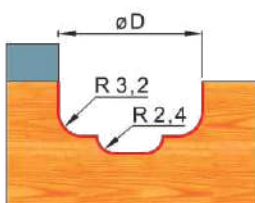

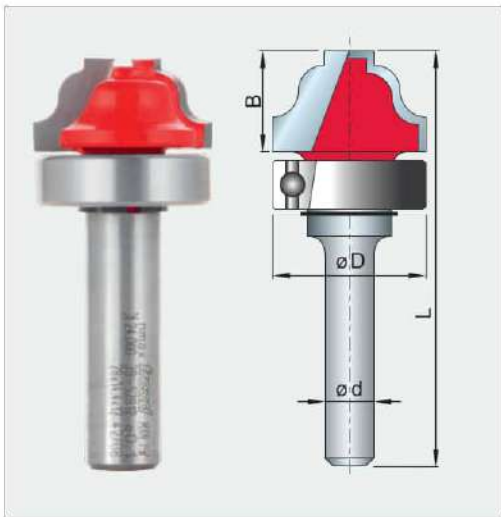

39-52 freud HW
KOPÍROVACIE FRÉZY PRE TVAROVÉ DRÁŽKY

ø D	B	L	R	ø d	Nr	€
19	12,5	55	3,2	6	2803952206	37,70
28	14	56,8	4	8	2803952808	37,50
28	14	64,1	4	12	2803952812	41,90

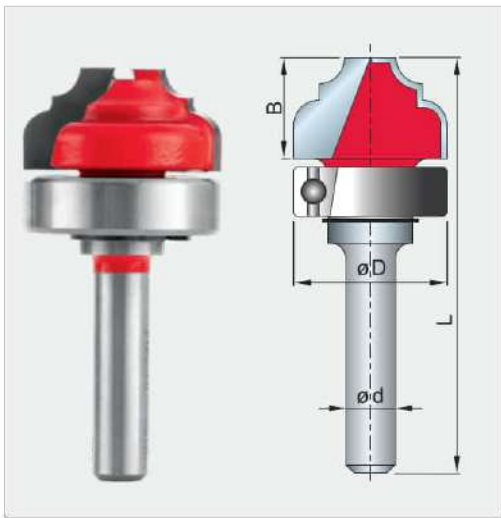
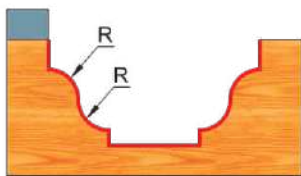

39-53 freud HW
KOPÍROVACIE FRÉZY PRE TVAROVÉ DRÁŽKY

ø D	B	L	R	ø d	Nr	€
19	12,3	55	3,2	6	2803953206	37,80
28	14	56,8	4	8	2803953808	37,50
28	14	64,1	4	12	2803953812	41,90

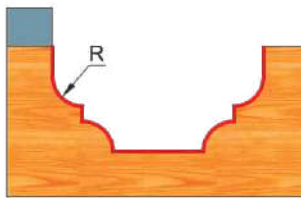

48-10 freud HW
OREZÁVACIA FRÉZA S PRIZNANÝM SPOJOM

ø D	C	B	L	ø d	Nr	€
15,8	12,7	25,4	71,5	8	2804810208	27,00
15,8	12,7	25,4	87,2	12	2804811212	33,00

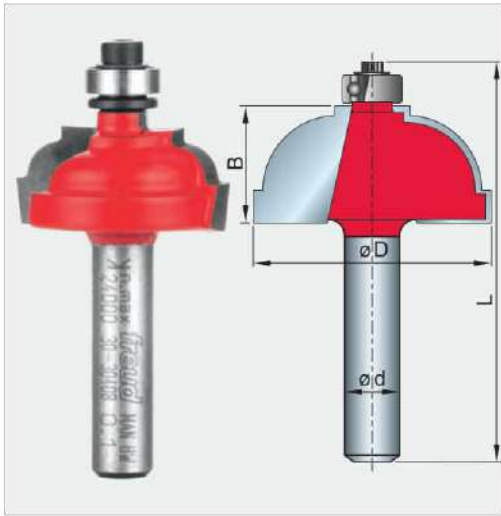
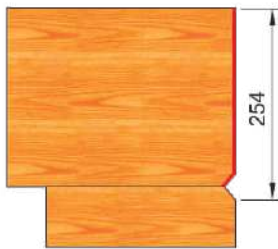

30-30 freud HW
KOPÍROVACIE PROFILOVÉ FRÉZY

ø D	B	L	R	ø d	Nr	€
28,6	12,7	54,2	4,8	8	2803030408	29,75
31,8	51,1	56,6	8	8	2803020208	33,95

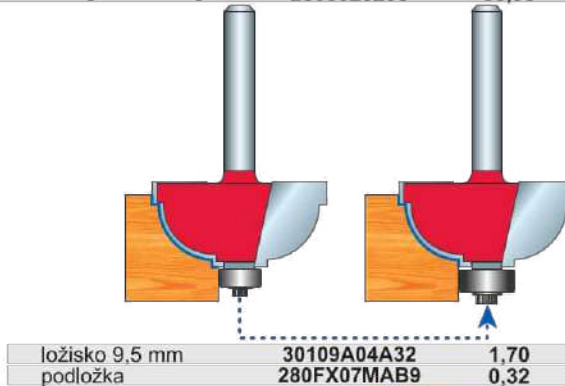
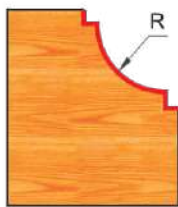

ložisko 9,5 mm	30109A04A32	1,70
podložka	280FX07MAB9	0,32

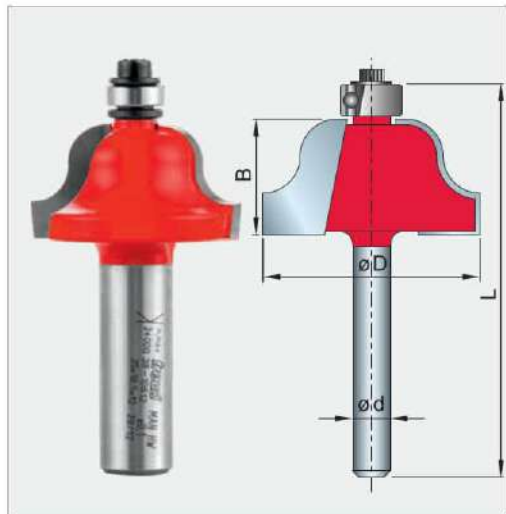

38-10		KOPÍROVACIE PROFILOVÉ FRÉZY				freud ^{HW}	
ø D	B	L	R	ø d	Nr	€	
27	13,3	54,7	4	6	2803810006	26,40	
27	13,3	54,7	4	8	2803810008	27,55	
35	18,5	60,5	6,4	8	2803810208	31,20	

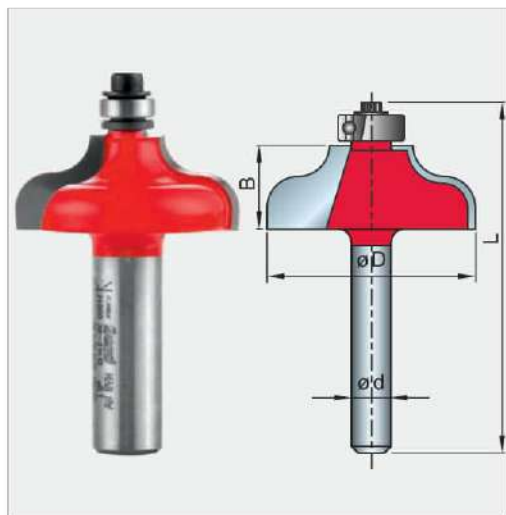
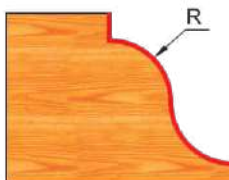

38-20		KOPÍROVACIE PROFILOVÉ FRÉZY				freud ^{HW}	
ø D	B	L	R	ø d	Nr	€	
31,8	12,7	54,2	4,8	8	2803820208	31,15	
38,1	15,7	57,4	6,4	8	2803820408	38,85	

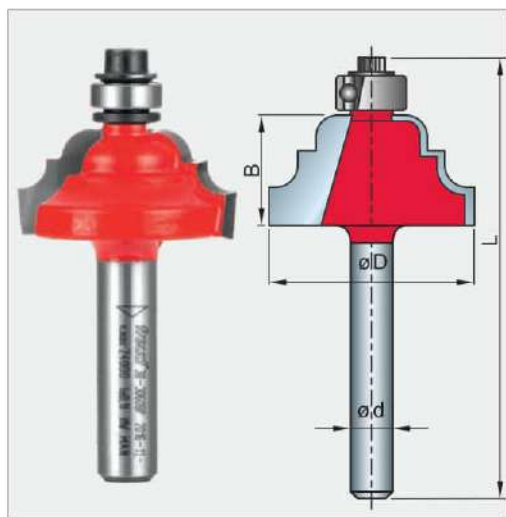
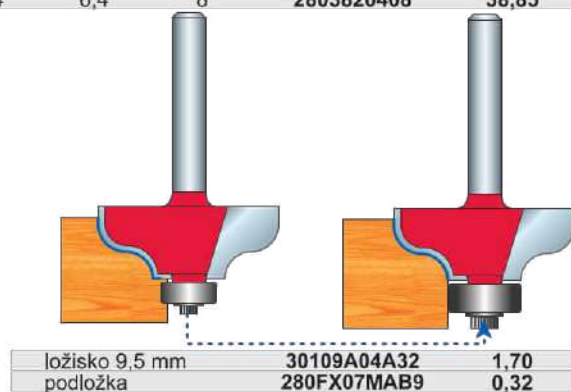
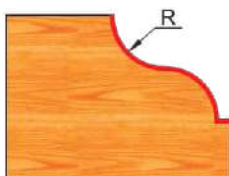

38-30		KOPÍROVACIE PROFILOVÉ FRÉZY				freud ^{HW}	
ø D	B	L	R	ø d	Nr	€	
29,4	13,5	55,5	4	8	2803830608	32,95	
38,9	18,3	60,3	6,4	8	2803830408	40,95	

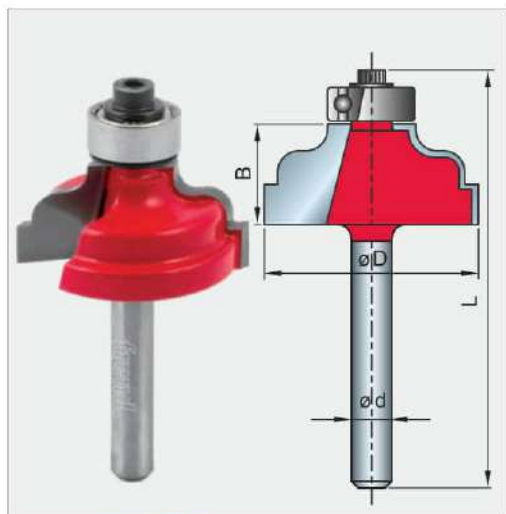
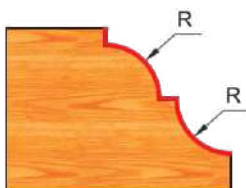

38-40		KOPÍROVACIE PROFILOVÉ FRÉZY				freud ^{HW}	
ø D	B	L	R	ø d	Nr	€	
31,8	15	56,7	3,2	8	2803840208	32,40	
34,9	14,3	62,8	4,8	12	2809900512	46,20	

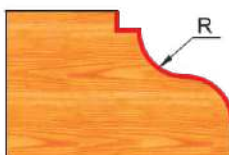

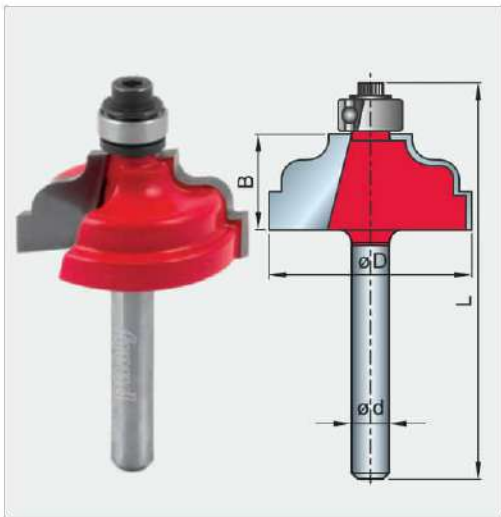

38-45		KOPÍROVACIE PROFILOVÉ FRÉZY			freud ^{HW}			
ø D	B	L	R	ø d	Nr	€		
31,8	15	56,8	3,2	8	2803845208	33,35		

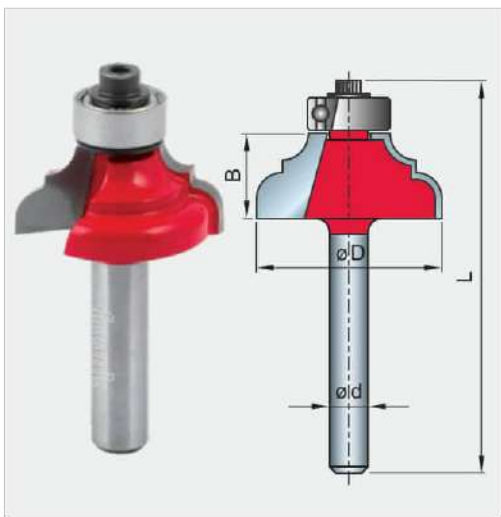
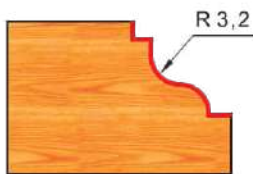

38-60		KOPÍROVACIE PROFILOVÉ FRÉZY			freud ^{HW}			
ø D	B	L	R1/R2	ø d	Nr	€		
28,5	12,7	54,7	4/4	8	2803860208	30,35		
34,9	18,3	60,3	6,4/4,8	8	2803860408	38,55		

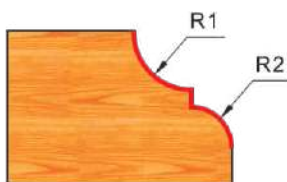

99-01		KOPÍROVACIE PROFILOVÉ FRÉZY			freud ^{HW}			
ø D	B	L	R	ø d	Nr	€		
41,3	15,9	63,5	9,9/4,4	8	2809901108	38,60		

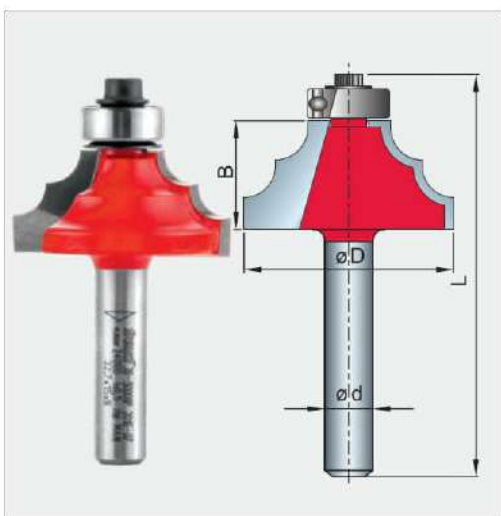
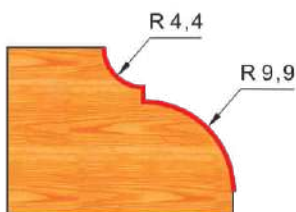

38-90		KOPÍROVACIE PROFILOVÉ FRÉZY			freud ^{HW}			
ø D	B	L	R	ø d	Nr	€		
32,7	15	57,2	5	8	2803890008	37,85		

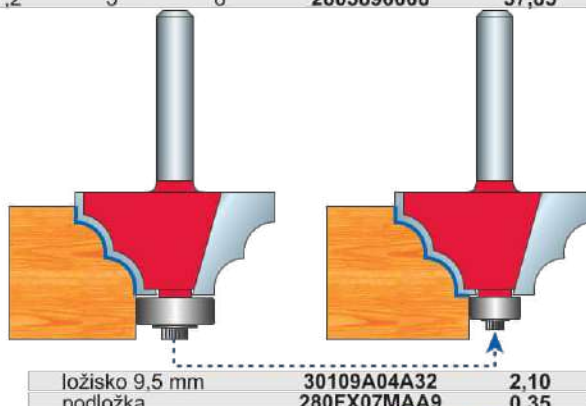
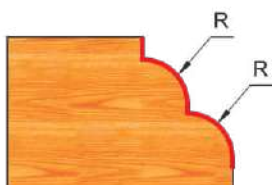

ložisko 9,5 mm	30109A04A32	2,10
podložka	280FX07MAA9	0,35



38-95		KOPÍROVACIE PROFILOVÉ FRÉZY				freud ^{HW}			
ø D	B	L	R	ø d	Nr	€			
32,7	15	57,2	5	8	2803895008	37,00			

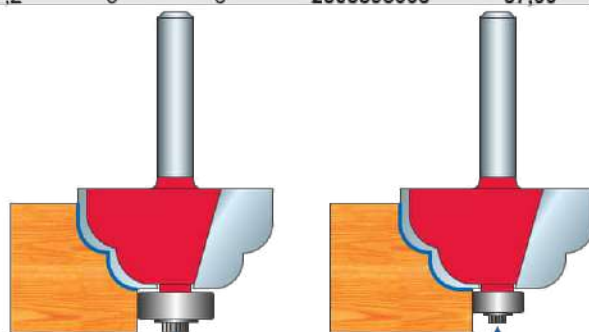
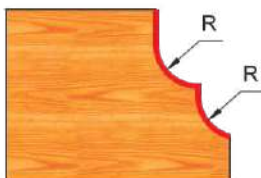

ložisko 9,5 mm	30109A04A32	2,10
podložka	280FX07MAA9	0,35

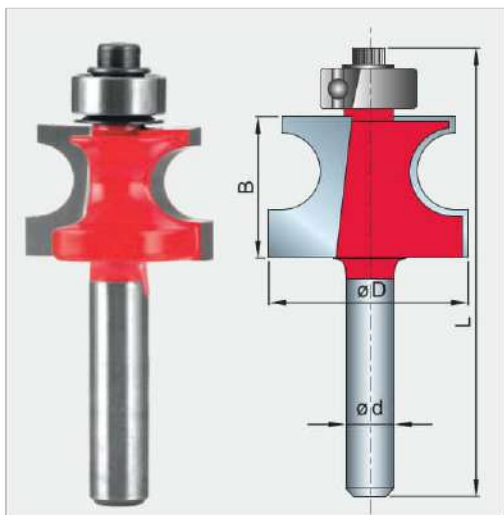

80-10		KOPÍROVACIE PROFILOVÉ FRÉZY				freud ^{HW}			
ø D	B	L	R	ø d	Nr	€			
22,2	14,3	57,1	3,2	8	2808010208	27,35			
25,4	17,5	60,3	4,8	8	2808010408	33,60			
30,2	22,2	65	7,1	8	2808010808	38,15			

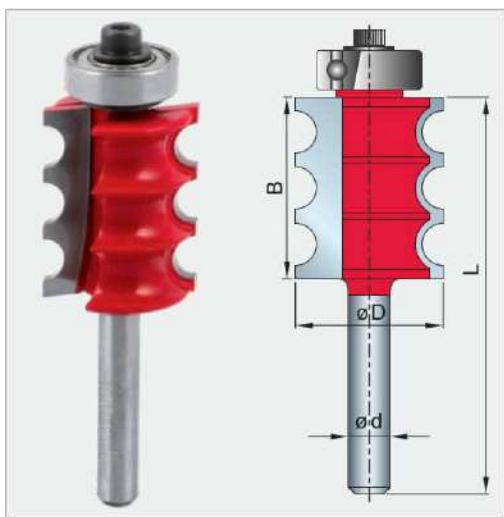
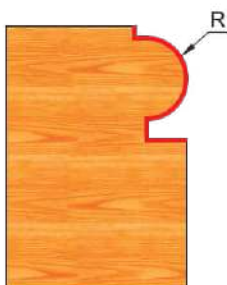

80-55		KOPÍROVACIE PROFILOVÉ FRÉZY				freud ^{HW}			
ø D	B	L	R	ø d	Nr	€			
22,2	27,4	69,9	3,2	8	2808055208	35,60			
22,2	27,4	79,4	3,2	12	2808057212	39,95			

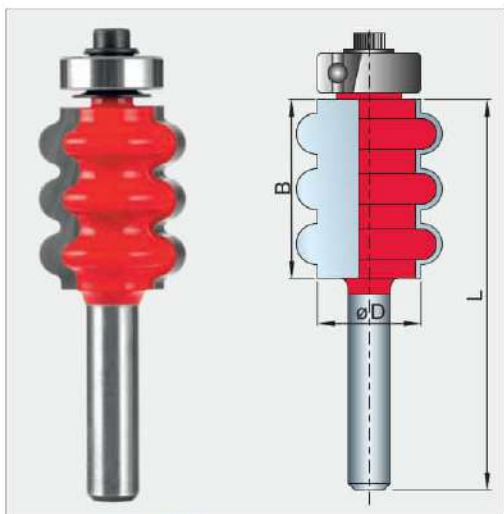
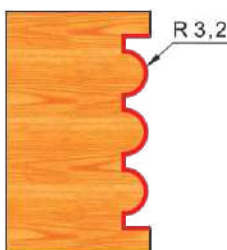

84-10		KOPÍROVACIE PROFILOVÉ FRÉZY				freud ^{HW}			
ø D	B	L	R	ø d	Nr	€			
22,2	27,4	65,9	3,2	8	2808410608	42,00			
22,2	27,4	76,2	3,2	12	2808412612	50,00			

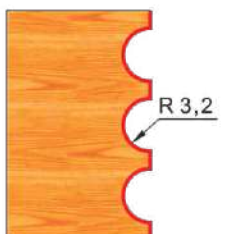

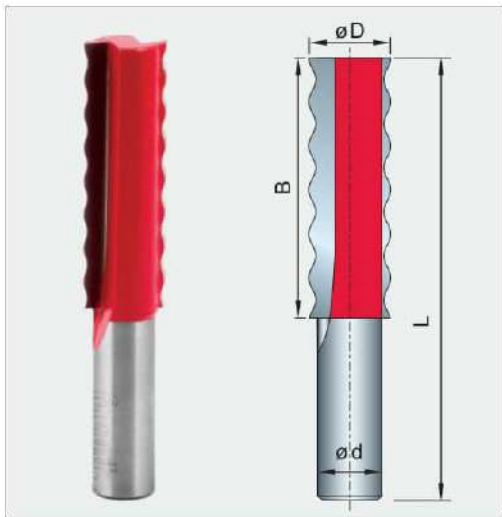

85-03		PROFILOVACIE FRÉZY		freud ^{HW}			
$\varnothing D$	B	L	R	$\varnothing d$	Nr	€	
16	51,3	88	4	12	2808503312	41,80	

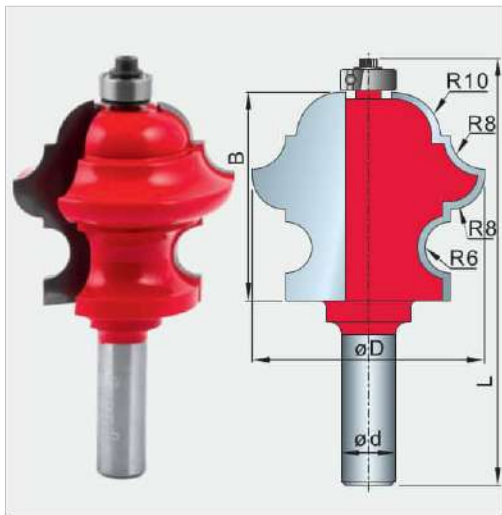

99-11		MULTIPROFILOVÉ KOPÍROVACIE FRÉZY		freud ^{HW}			
$\varnothing D$	B	L	$\varnothing d$	Nr	€		
54,7	49	102	12	28099PK112	95,00		

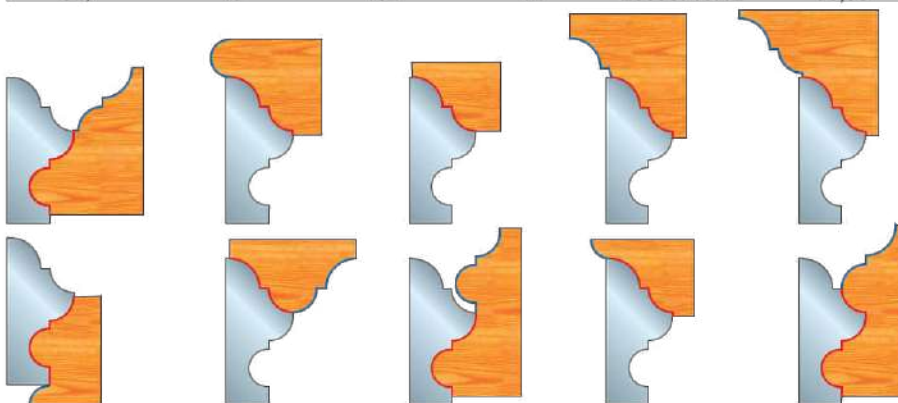

99-21		PROFILOVACIE FRÉZY		freud ^{HW}			
Profil	$\varnothing D$	B	L	$\varnothing d$	Nr	€	
A	31,8	20	58	12	28099PK212	49,00	
B	31,8	23,8	72	12	28099PK312	52,00	

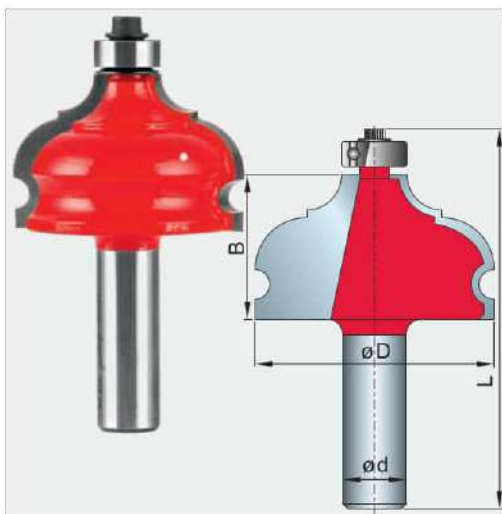
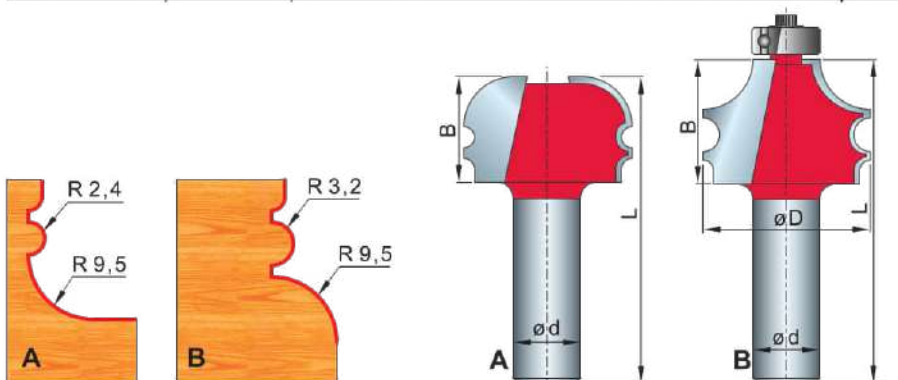

99-00		KOPÍROVACIE PROFILOVÉ FRÉZY		freud ^{HW}			
$\varnothing D$	B	L	$\varnothing d$	Nr	€		
44,4	28,6	77,1	12	2809900812	63,10		

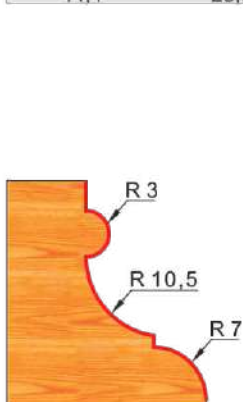

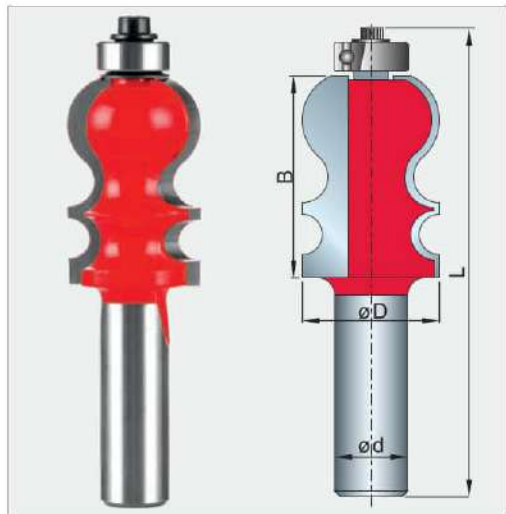

99-01 KOPÍROVACIE PROFILOVÉ FRÉZY		freud ^{HW}				
Profil	ø D	B	L	ø d	Nr	€
A	23,8	35	83,5	12	2809901312	50,70
B	23,8	35	83,5	12	2809901212	50,70

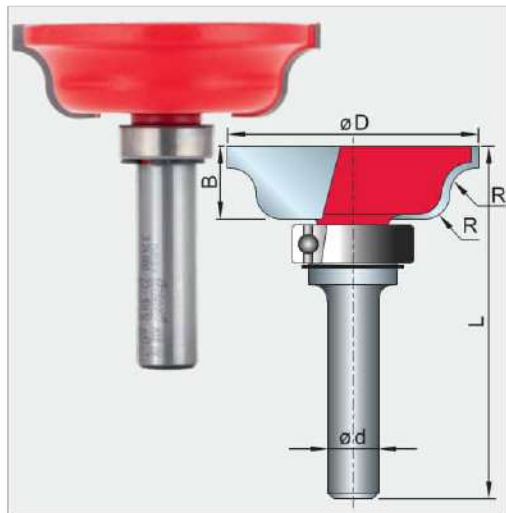
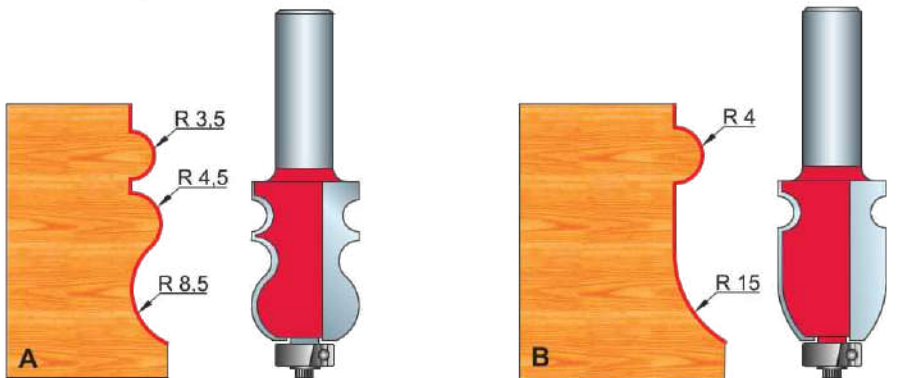

23-10 KOPÍROVACIE PROFILOVÉ FRÉZY		freud ^{HW}					
ø D	B	t	L	R	ø d	Nr	€
39,5	11,5	10,2	54,6	4	8	2802310008	41,95
54	11,5	17,5	58	4	12	2802310212	63,55
60,5	17,3	20,7	63,8	6,35	12	2802310412	69,30

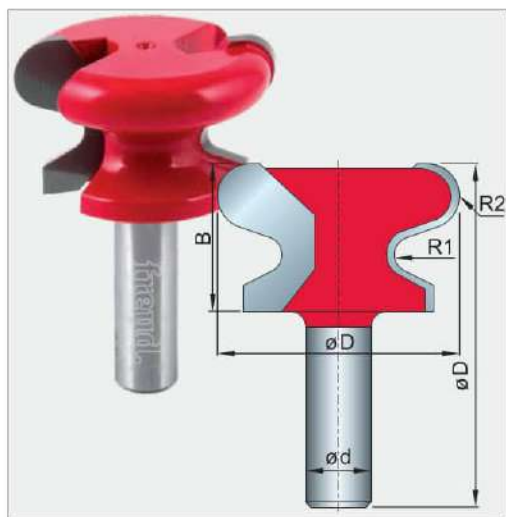
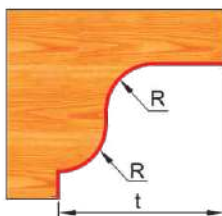

24-78 FRÉZY NA ZÁSUVKOVÉ MADLÁ		HW					
Profil	ø D	B	L	Z	ø d	Nr	€
A	19	18	55	2	8	23324783519000R	126,00
B	19	19	57	2+1	12	606E116190R	64,60
C	38,1	17	59	2	12	606E116381R	97,40
D	47	28,7	66,7	2	12	2809900712	66,80

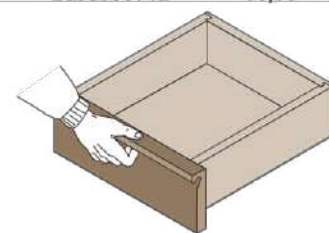
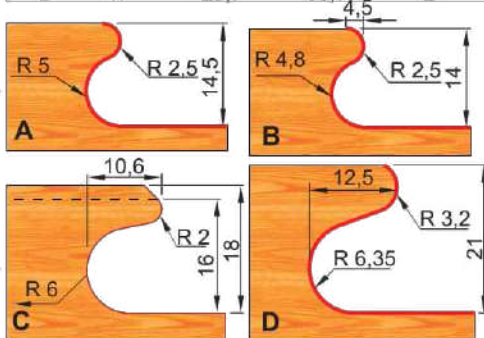

99-27 FRÉZY NA SCHODISKOVÉ MADLO		freud ^{HW}				
ø D	B	L	R1/R2	ø d	Nr	€
A	63,5	16	30/8	12	2809902712	75,30
B	35	38,5	3,2	12	2809907212	63,10

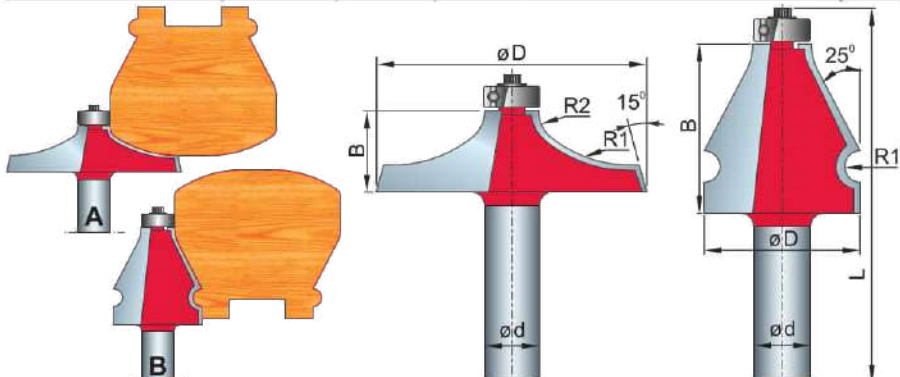



99-05		FRÉZY NA ŠPALETOVÉ OKNÁ				freud ^{HW}			
Profil	ø D	B	L	R	ø d	Nr	€		
A	38	15,5	53,5	6	12	2809905012	39,60		
B	34	35,9	78,4	6	12	2809905112	85,40		

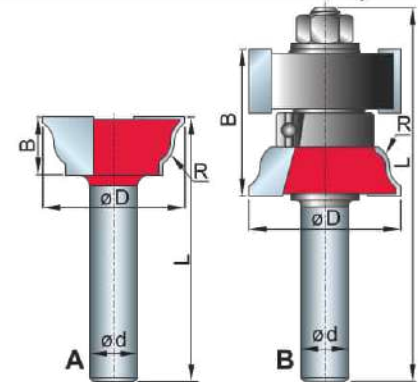
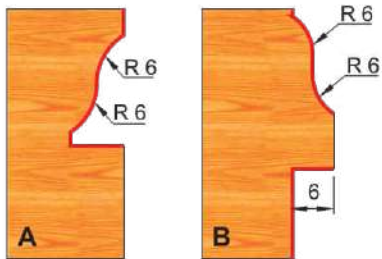

99-26		SADY NA NÁBYTKOVÉ DVIERKA				freud ^{HW}			
Profil	R	ø d	Nr		€				
A	4,5/5,5	12	2809926112		120,00				
B	5,5	12	2809926012		120,00				
C	7	12	2809926312		120,00				

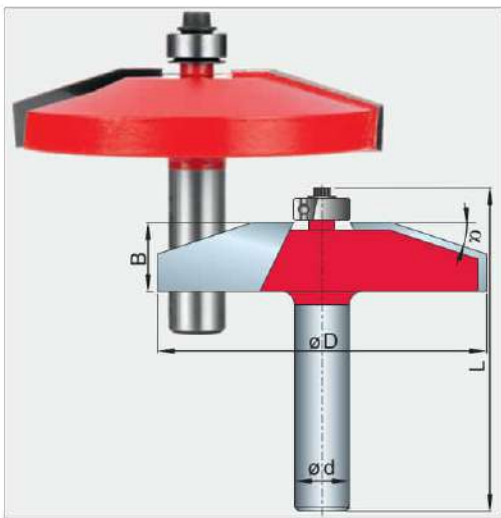
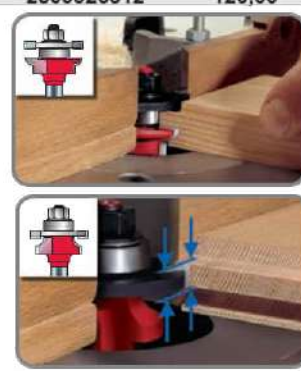
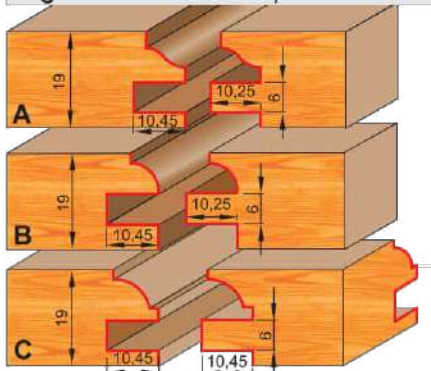

99-22		VÝPLŇOVÉ FRÉZY S LOŽISKOM				freud ^{HW}			
Profil	ø D	B	L	R	ø d	Nr	€		
A	76,2	16	64,7	2xR16	12	2809922112	90,70		
B	76,2	16	64,7	18°	12	2809922312	90,70		
C	76,2	16	64,7	18°	12	2809922412	92,80		
D	89	16	64,7	R38,1	12	2809922512	88,50		

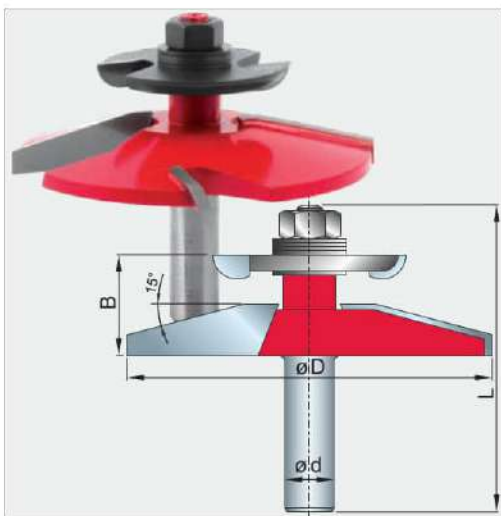
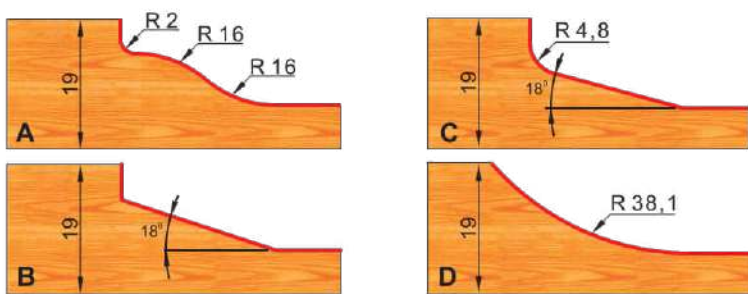

99-56		VÝPLŇOVÉ FRÉZY - ZOSTAVY				freud ^{HW}			
Profil	ø D	B	L	R	ø d	Nr	€		
A	89	25	75	15°	12	2809956612	140,00		
B	89	25	75	R38	12	2809956912	140,00		
C	89	25	75	2xR30	12	2809957112	155,00		

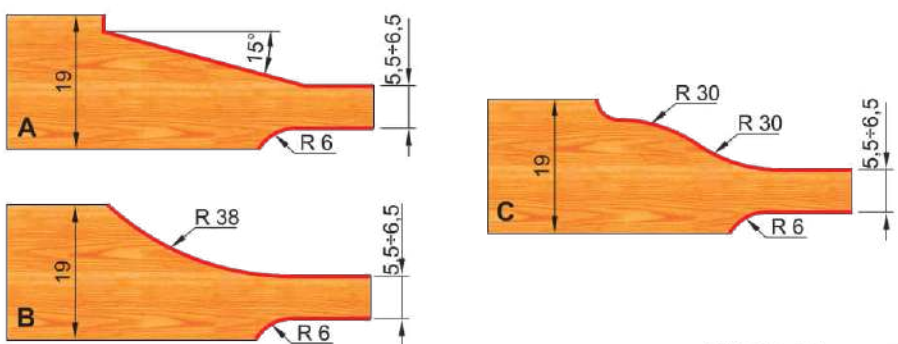

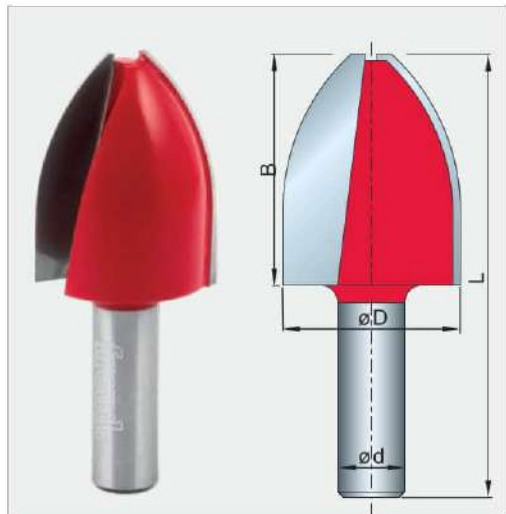

99-32 VÝPLŇOVÉ FRÉZY VERTIKÁLNE freud^{HW}

Profil	ø D	B	L	R	ø d	Nr	€
A	31,8	41,5	79,5	2xR16	12	2809932212	57,30
B	31,8	41,5	79,5	18°	12	2809932312	57,30
C	31,8	41,5	79,5	15°R15	12	2809932412	57,30

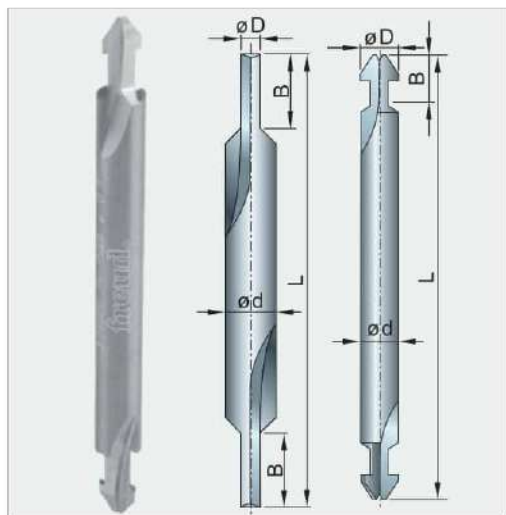
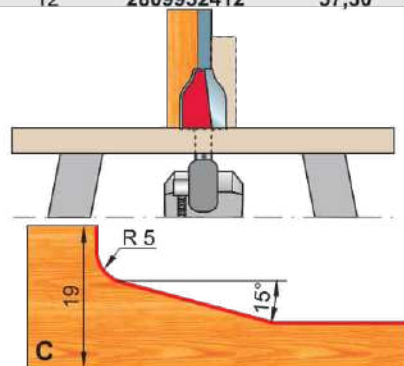
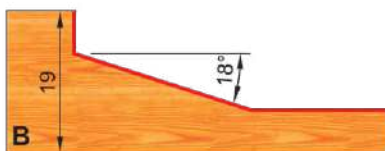
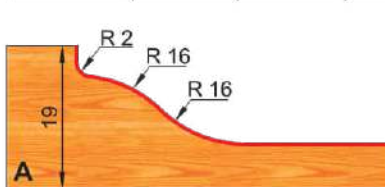

04-90 FRÉZY NA TESNENIE freud^{HW}

Profil	ø D	B	L	ø d	Nr	€
A	3	8	70	6	2800490006	41,48
B	3	8	70	6	2800495006	42,00

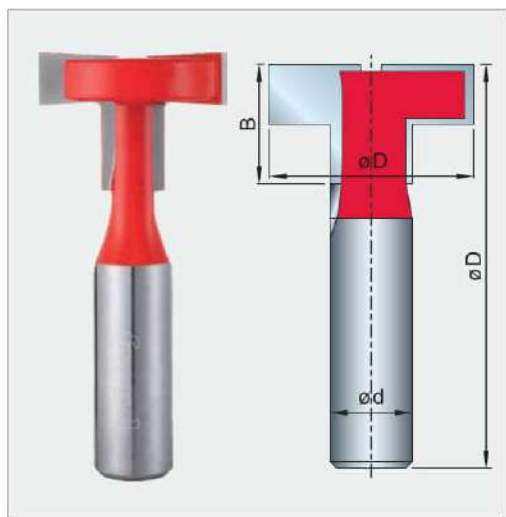
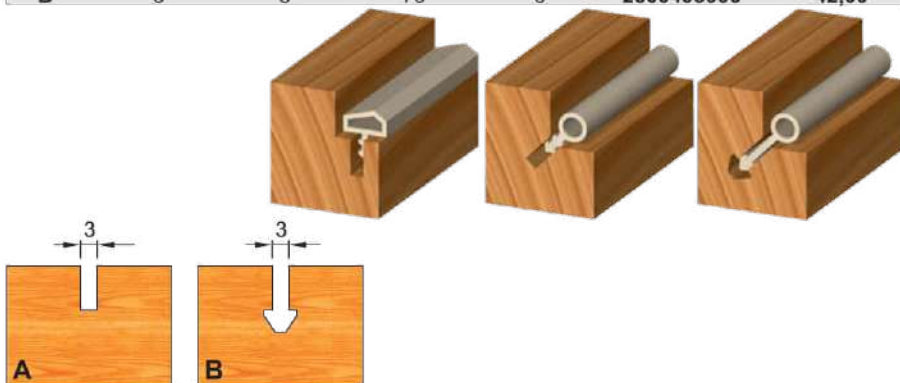

70-10 FRÉZY NA T-DRÁŽKY freud^{HW}

Profil	ø D	B	L	ø d	Nr	€
A	10	17	44	6	2807010406	24,00
B	28,58	20,6	20,6	12	2805252212	40,00
C	30	18	61	12	2805252612	50,00

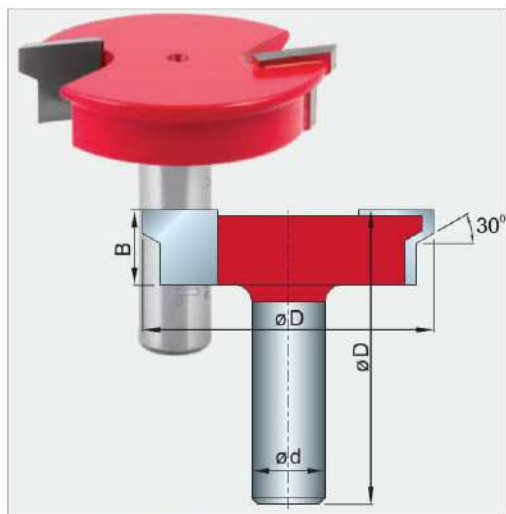
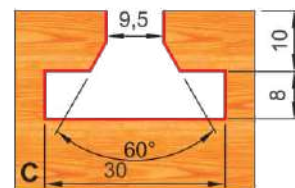
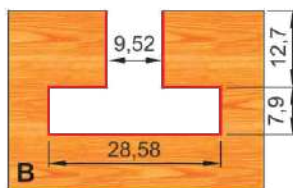
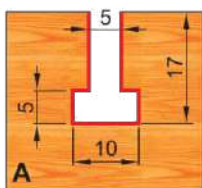

99-24 FRÉZY NA ZÁSUVKOVÝ ČELNÝ SPOJ freud^{HW}

ø D	B	L	ø d	Nr	€
50,5	13	51	12	2809924012	47,40

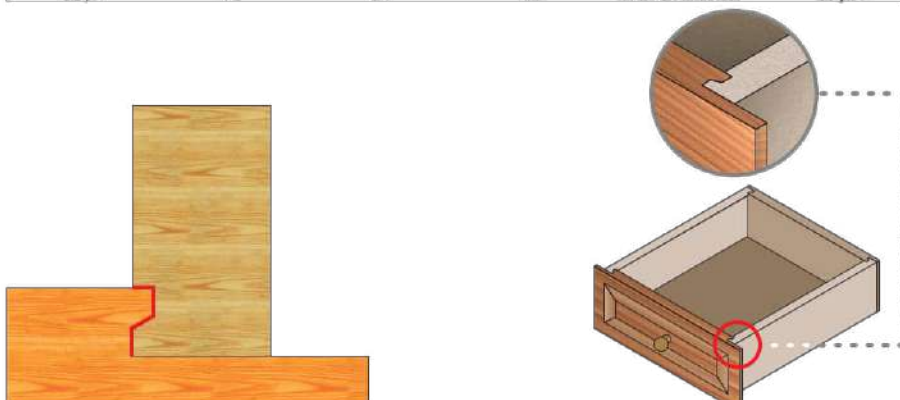

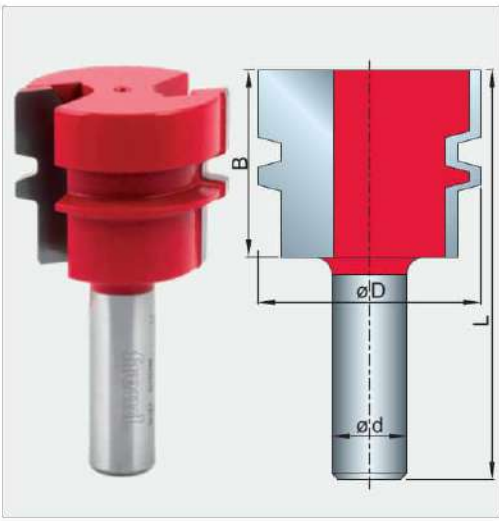

	99-031 FRÉZY NA ŠKÁROVKU	freud ^{HW}			
$\varnothing D$	B	L	$\varnothing d$	Nr	€
38	32	70	12	2809903112	48,50

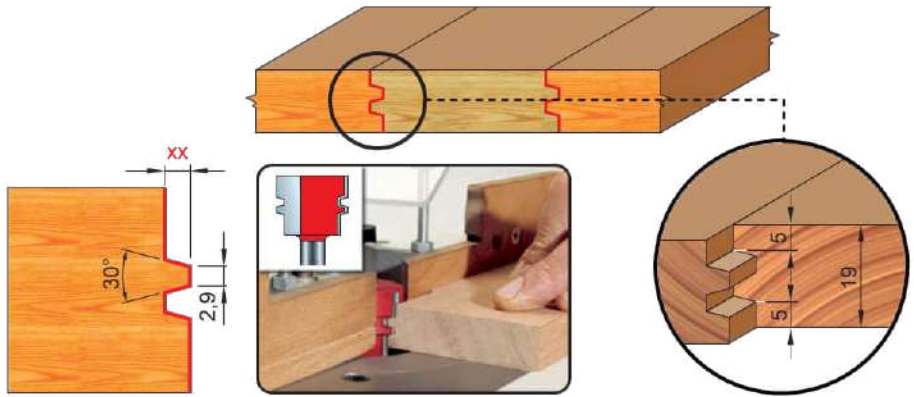

	99-04 SADA FRÉZ NA 8-UHOLNÍK	freud ^{HW}			
$\varnothing D$	B	L	$\varnothing d$	Nr	€
37,3	22,2	54,2	12	2809904308	91,20

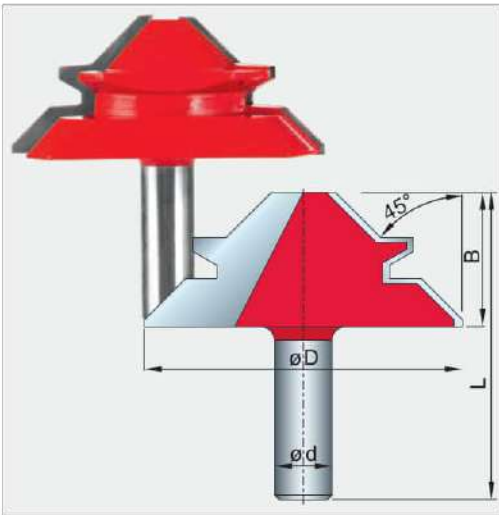
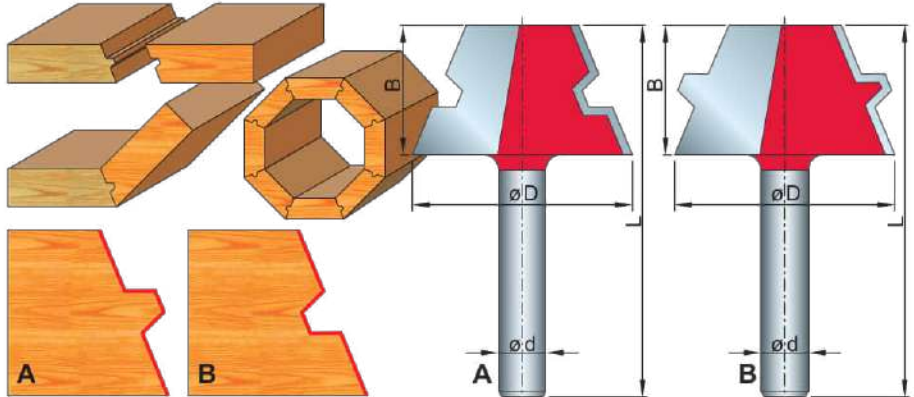

	99-035 FRÉZY NA ROHOVÝ SPOJ 45°	freud ^{HW}				
Profil	$\varnothing D$	B	L	$\varnothing d$	Nr	€
A	55	23	61	12	2809903512	67,80
B	70	29,5	67,5	12	2809903412	95,00

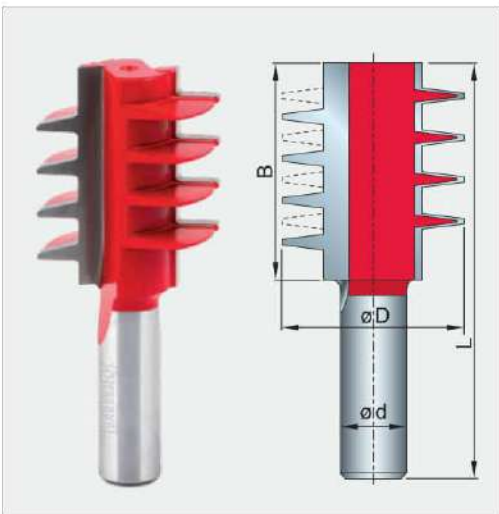
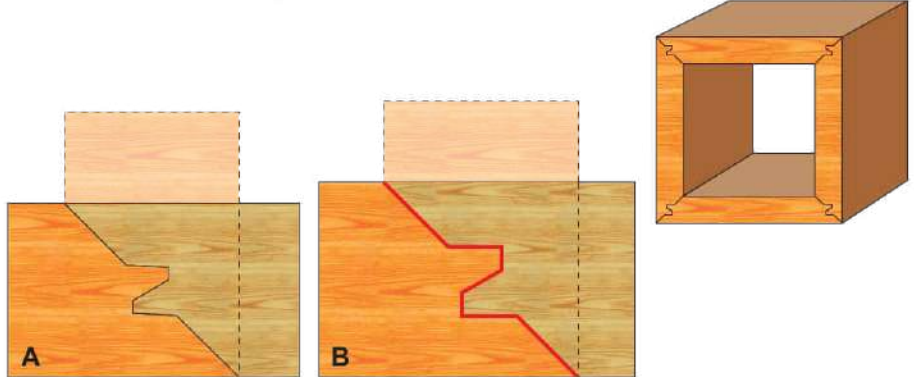

	99-037 FRÉZY NA MINICINK 8/8	freud ^{HW}			
$\varnothing D$	B	L	$\varnothing d$	Nr	€
35	41,5	78	12	2809903712	85,90

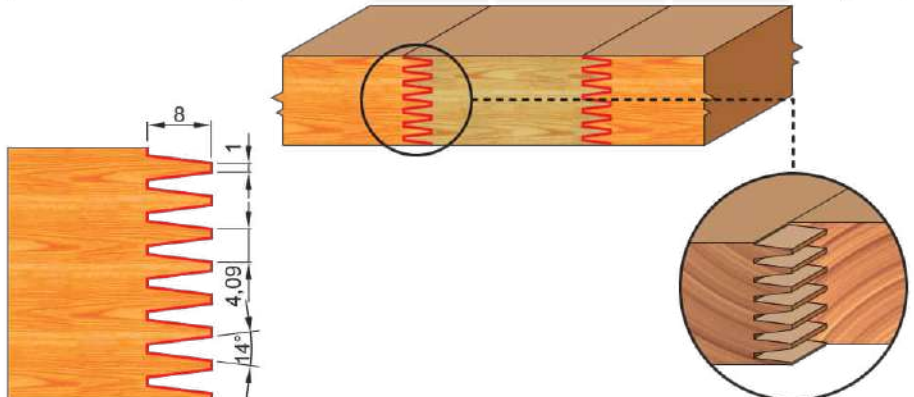

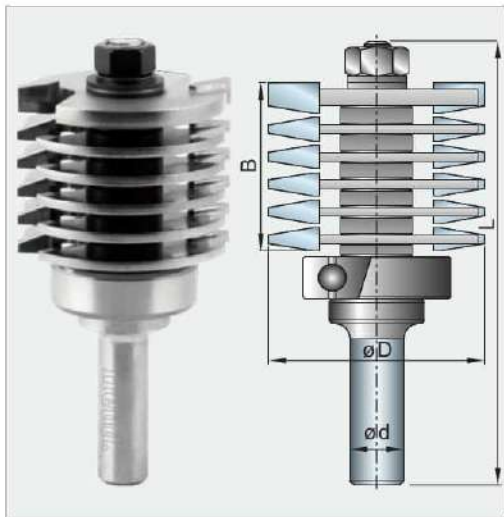

	99-039 FRÉZY NA MINICINKE 8/8	freud ^{HW}			
ø D	B	L	ø d	Nr	€
50,8	45,2	108	12	2809903912	140,50

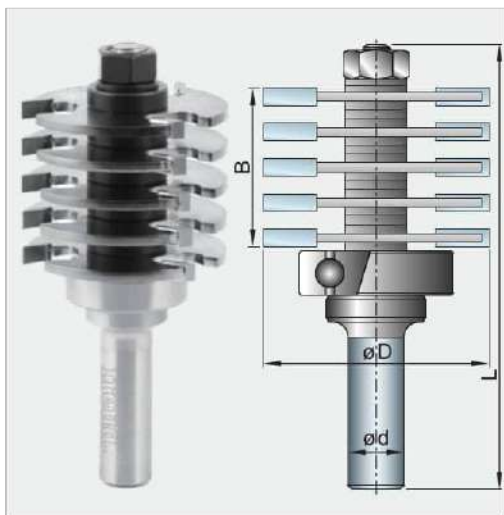
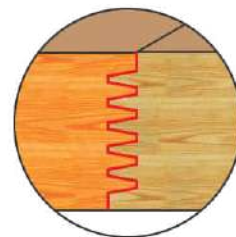
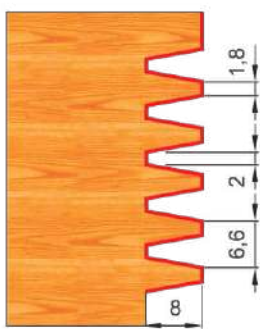

	99-042 FRÉZY NA HREBEŇOVÝ SPOJ 4X9,5	freud ^{HW}			
ø D	B	L	ø d	Nr	€
47	36	101	12	2809904212	98,60

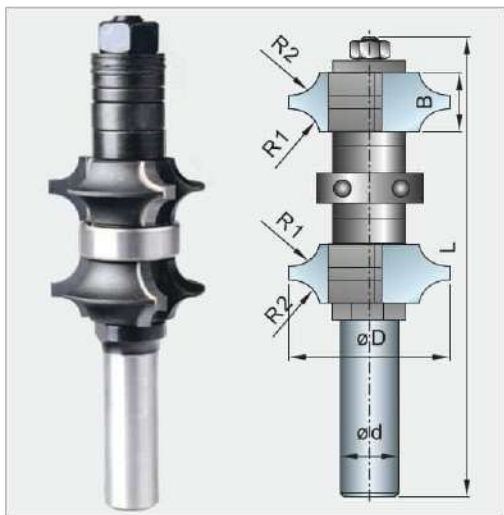
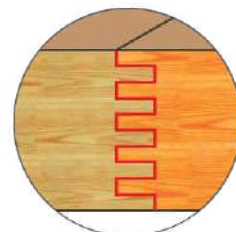
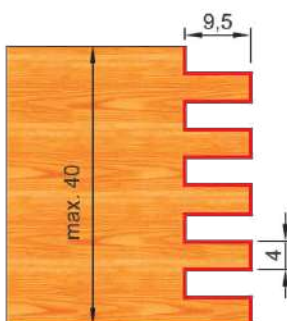

	186 STAVITELNÉ ZAOBLOVACIE FRÉZY Z=3+3	Klein ^{HW}					
ø D	B	L	R1	R2	ø d	Nr	€
35	14	108	6,4	4,8	12	606E186350R	124,20

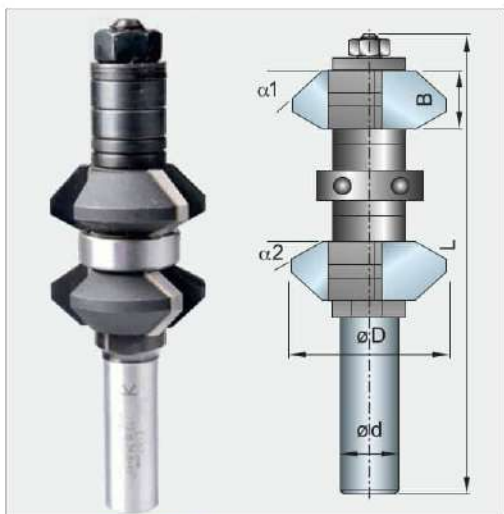
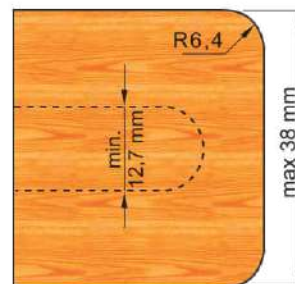
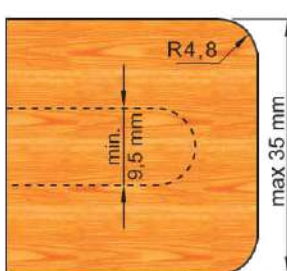

	187 STAVITELNÉ ZRÁŽACIE FRÉZY Z=3+3	Klein ^{HW}			
ø D	B	L	ø d	Nr	€
35	14	108	12	606E187350R	124,20

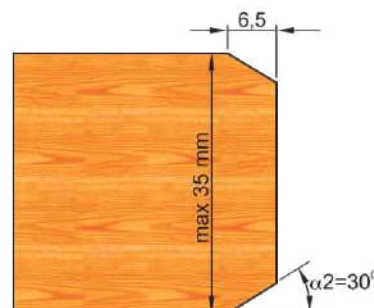
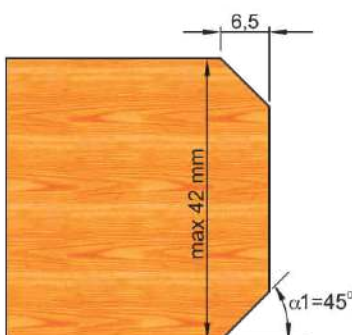



FŘEZY NA OBLÚKOVÉ OKNA						
Nástroj	ø D	B	L	ø d	Nr	€
A	8	10	50	8	606C112030R	28,60
B	14	16	45	8	606C199140R	58,30
C	16,5	11	45	8	606C199165R	60,00
D	6	14	85	8	606U202060R	21,20
E	6	40	100	8	606U201061R	20,80
F	20	33	68	8	606C199200R	75,50

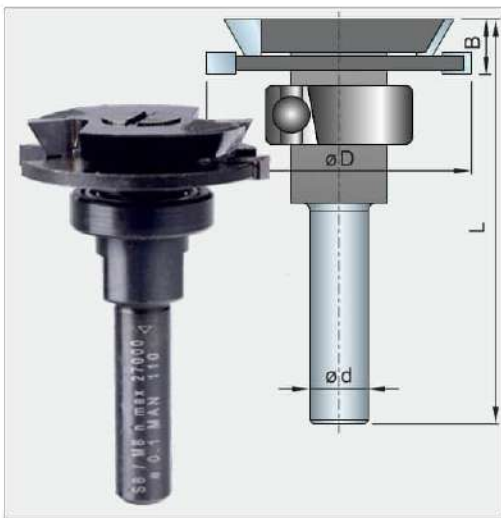
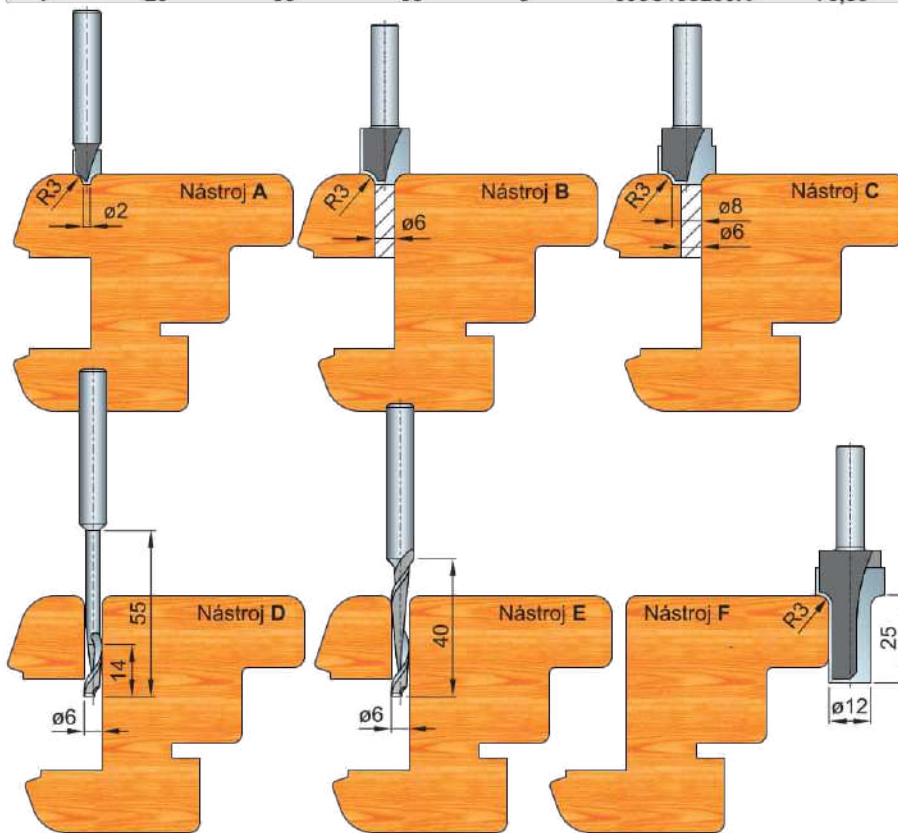

25-18 FŘEZY NA PŘÍDAVNÉ TESZENIE						
Profil	ø D	B	L	ø d	Nr	€
A	36	7,5	55	8	23325183510000R	196,00
B	50	10	57	8	23325183520000R	238,30

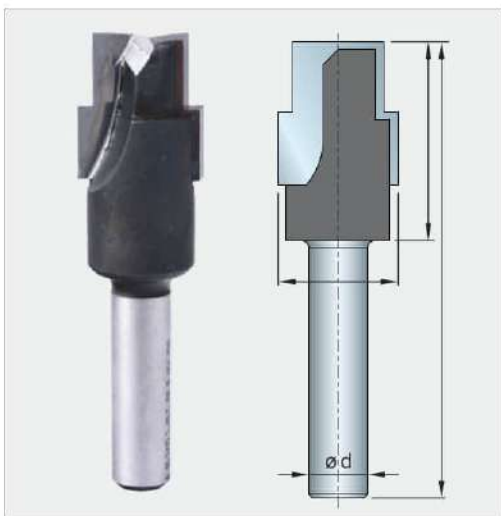
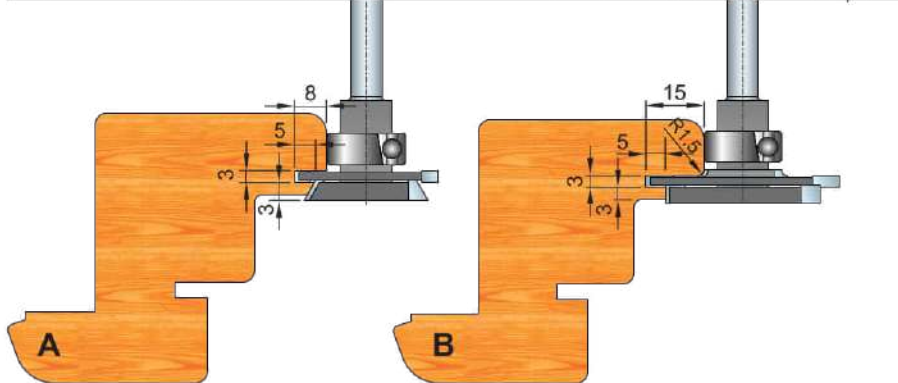

25-54 FŘEZY NA OKENNÉ KOVANIE					
ø D	B	L	ø d	Nr	€
16,3	19,5	62	8	23325543516395R	105,50





W122-124		DRAŽKOVACIE ZÁVRTNÉ FRÉZY Z=1+1 VERSOFIX		HW	MAN
ø D	B	L	ø d	Nr	€
8	20	63	8	606W122080R	116,00
10	20	63	8	606W122100R	116,00
12	20	63	8	606W122120R	116,00
16	30	74	8	606W122160R	125,00
12	20	68	12	606W124120R	123,00
16	50	94	12	606W124161R	148,00
20	50	94	12	606W124201R	154,00



W113-114		OREZÁVACIE FRÉZY ŽILETKOVÉ - SPODNÉ LOŽISKO		HW	MAN
ø D	B	L	ø d	Nr	€
19	30	70	8	606W113190R	58,50
19	50	100	12 *	606W114192R	89,80

* dvojité ložisko



W115-116		OREZÁVACIE FRÉZY ŽILETKOVÉ - HORNÉ LOŽISKO		HW	MAN
ø D	B	L	ø d	Nr	€
19	30	70	8	606W115190R	61,30
19	50	100	12 *	606W116192R	89,80

* dvojité ložisko

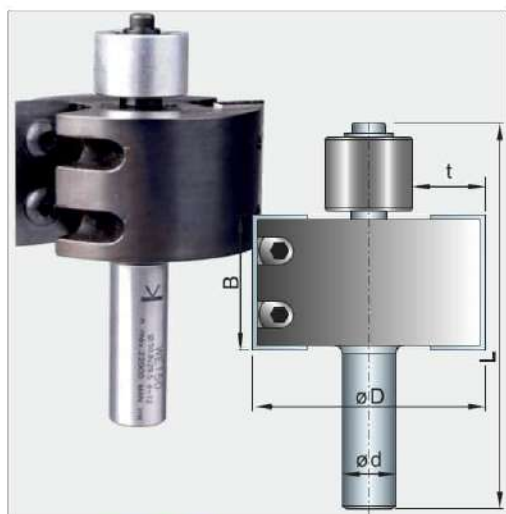

WE150		FALCOVACIA ŽILETKOVÁ FRÉZA		HW	MAN	
ø D	B	L	t	ø d	Nr	€
51	29,5	84	1,6	12	606WE150510R	126,00
sada ložísk 16ks			1,6~18,25		606Z050999N	109,90



FRÉZY NA PRACOVNÉ DOSKY HW

	ø D	B	L	ø d	Nr	€
žiletková	12	50	95	12	23322356512050R	104,00
DIA	12	45	95	12	235PP10D124512R	99,00

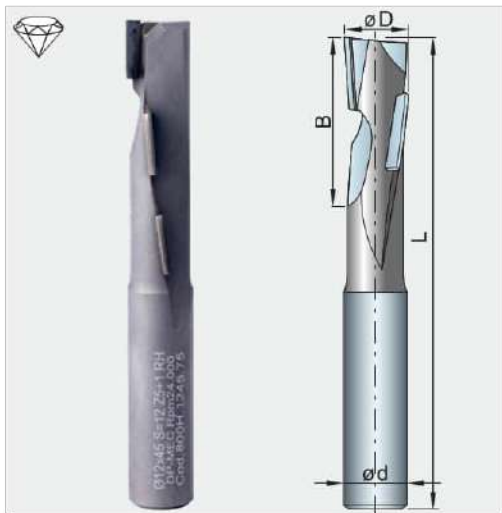
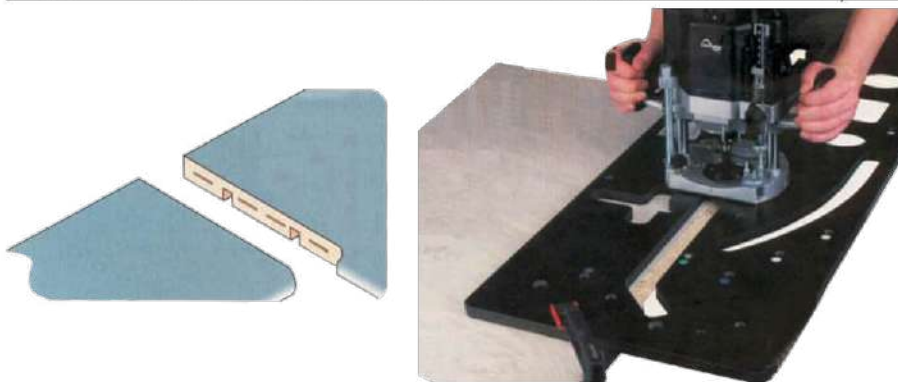

800H FORMÁTOVACIE DIA FRÉZY POZITÍVNO-NEGATÍVNE DIA

ø D	B	L	Z	ø d	Nr	€
8	27	80	3+1	8	230U800H.0827.75	96,70
10	27	80	3+1	10	230U800H.1027.75	103,62
12	27	80	3+1	12	230U800H.1227.75	112,60
12	45	90	5+1	12	230U800H.1245.75	160,00

* telo HM

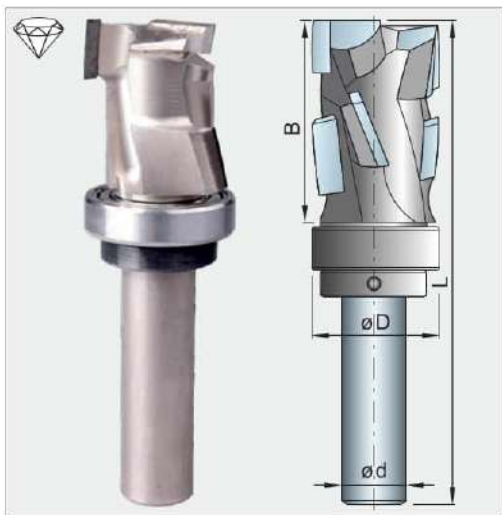

214-TBB KOPÍROVACIE DIA FRÉZY - HORNÉ LOŽISKO DIA

ø D	B	L	Z	ø d	Nr	€
24	27	80	3+1	12	530D21415TBB	87,00
24	43	95	5+1	12	530D21417TBB	126,00



214 KOPÍROVACIE DIA FRÉZY - SPODNÉ LOŽISKO DIA

ø D	B	L	Z	ø d	Nr	€
12,7	27	80	3+1	8	530D21410	78,30
12,7	43	100	5+1	12	530D21414	140,00

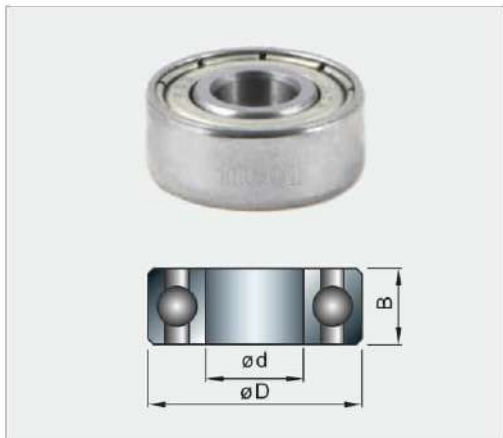

LOŽISKÁ											
ø D	ø d	B	Nr	€	ø D	ø d	B	Nr	€		
6,35	3,17	2,8	30106A03A28	1,60	16	8	5	30116008050	7,00		
9,5	4,76	3,2	30109A04A32	2,10	18	12	4	30118012040	6,00		
12	8	3,5	30112008035	4,20	19	6	6	30119006060	7,10		
12,7	4,76	5	30112A04A50	2,00	19	6,35	7	30119006A70	6,25		
12,7	6,35	4,8	30112A06A48	5,60	19	8	6	30119008060	10,58		
13	5	4	30113005040	5,00	19	12,7	4	30119012A40	7,92		
13	6	5	30113006050	3,30	22	8	6	30122008060	1,70		
15	6	5	30115006050	2,25	22,2	9,52	7	30122A09A70	4,00		
15,8	4,76	5	30115A04A50	2,67	24	8	8	30124008080	4,00		
15,8	6,35	5	30115A06A50	2,08	28	12	8	30128012080	3,75		
16	5	5	30116005050	5,42	28,5	12,7	8	30128A12A80	5,00		
16	6	6	30116006060	7,10							



31-05 REDUKČNÉ VLOŽKY PRE STOPKOVÉ NÁSTROJE					
ø D	ø d	H	Nr	€	
8	25	25	2803105MVY250	10,90	
8	6,35	25	2803105MVX250P	10,90	
10	8	25	2803105MTV250P	10,90	
12	6	25	2803105MSY250P	10,90	
12	8	25	2803105MSV250P	10,90	
12	10	25	2803105MST250P	10,90	
12,7	8	25	2803105MRV250	10,90	

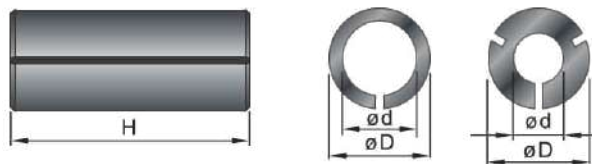

78Z KLÚČE - ŠTANDARD - IMBUS			
imbus L	Nr	€	
hex 1,3	615048078Z013	4,00	
hex 2	615048078Z020	1,50	
hex 2,5	615048078Z025	1,50	
hex 3	615048078Z030	1,50	

STAMPK KLÚČE - ŠTANDARD - TORX			
TORX	Nr	€	
klúč T9	550STAMPK124	4,00	
klúč T10	550STAMPK129	5,00	
klúč T15	550STAMPK132	5,00	
klúč T20	550STAMPK128	5,00	



2617M PODLOŽKY HLADKÉ					
ø D	ø d	B	Nr	€	
14	8,4	1,6	2802617MBG9	2,30	
16	8,4	1,6	2802617MAG9	1,75	

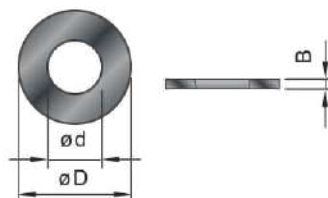

FX07M PODLOŽKY S ODSADENÍM					
ø D	ø d	B	Nr	€	
9	4,76	2	280FX07MAA9	0,35	
12	4,76	1,1	280FX07MAB9	0,35	

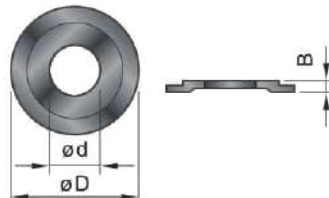

PT11M BLOKOVACIE KRÚŽKY			
ø d	Nr	€	
6	280PT11M060	3,80	
8	280PT11M080	3,80	
10	280PT11M100	4,20	
12	280PT11M120	4,20	

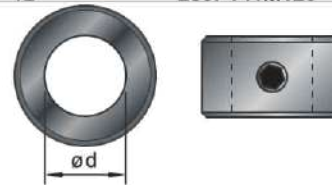

2607M SKRUTKY S VALCOVOU HLAVOU					
ø d	L	HEX	Nr	€	
M3	6	2,5	2802607MAA9	1,25	
M3	8	2,5	2802607MAB9	1,25	
M3	10	2,5	2802607MAC9	1,25	
M4	8	3	2802607MBB9	1,25	

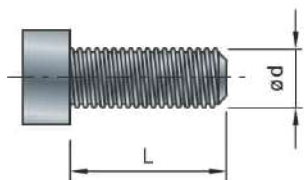

260M SKRUTKY S PRÍRUBOU					
ø d	L	HEX	Nr	€	
M3	7,6	2,5	2802607M001	1,25	

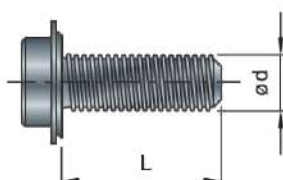

0480 SKRUTKY S POLGULATOU HLAVOU					
ø d	ø D	L	Nr	€	
M3	5	6	280VT72MAA9	3,00	
M3,5	5	7	6150480730407	7,20	
M3,5	5	9	6150480730409	7,20	
M3,5	8	7	615048074P350	1,44	
M4	5	8	280VT70MAA9	2,80	
M4	10	8	615048074P460	1,44	
M4	5	10	280VT71MAA9	2,80	

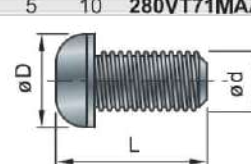

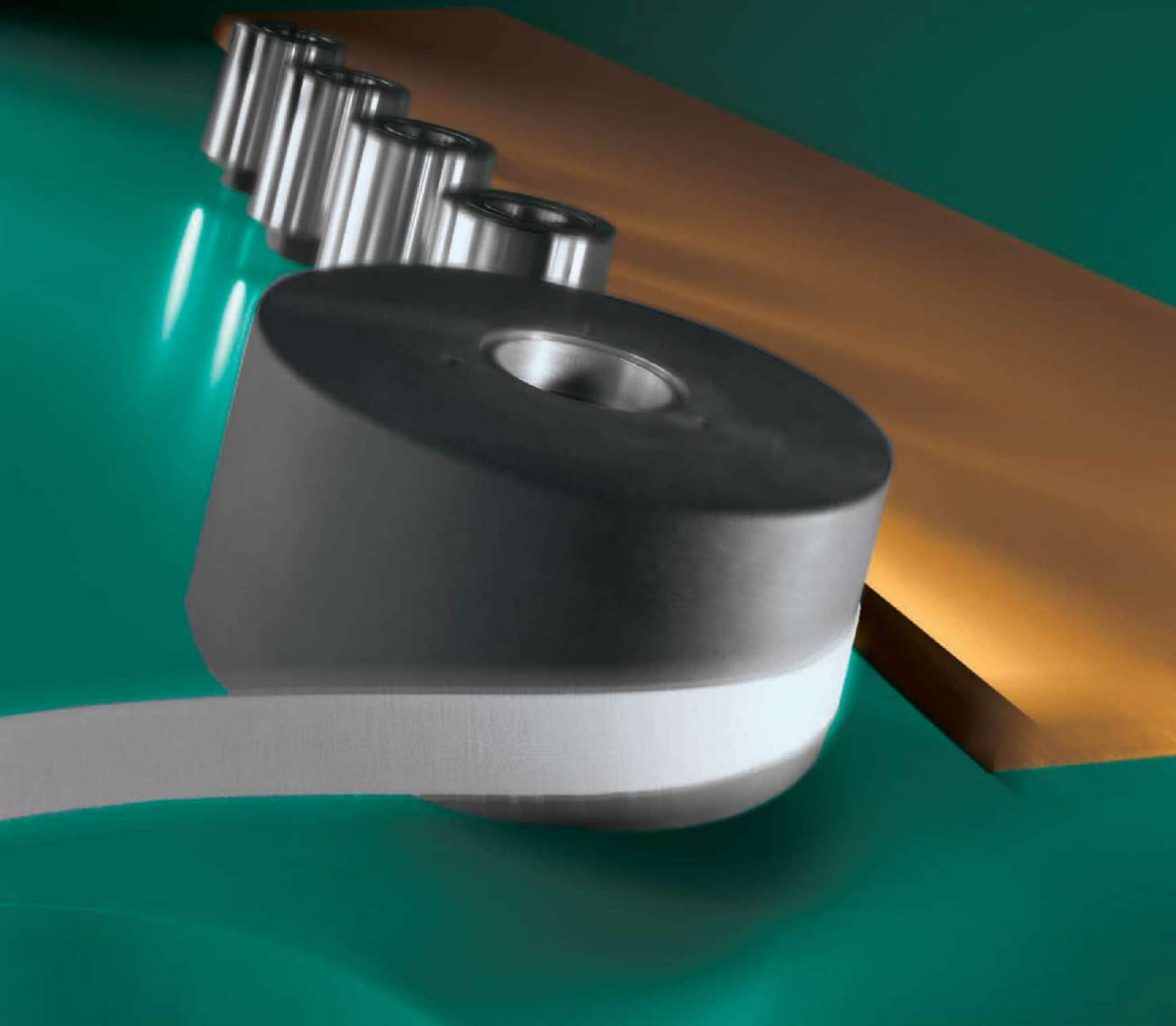

astefani

HC HOMAG

FELDER



HC HOMAG

IHI HOLZHER

PAUL OTT



KBT

NanXing



OLEPOVANIE



eshop.woodb.sk



FF71D ZAROVNÁVACIE FRÉZY PRE OLEPOVAČKY 30°							DIA		
ø D	TYP	B	B1	ø d	Z	Nr RH	(L)	€	
80	A	56	58	30	2	235FF60DS036075	(L)	344,00	
100	B	48	25	30	2	235FF71D1002ABR	(L)	309,40	
100	D	48	39	30	2	235FF71D1002ACR	(L)	309,40	
100	B	65	25	30	2	235FF71D1002ADR	(L)	432,90	
100	D	65	39	30	2	235FF71D1002AER	(L)	432,90	
100	C	48	39	30	3	235FF71D1003ABR	(L)	463,90	
100	AS	48	48	30	3	235FF71D1003AIR	(L)	371,00	
100	AS	65	65	30	3	235FF71D1003ALR	(L)	556,00	
100	C	65	39	30	3	235FF71D1003AER	(L)	649,20	
125	CS	45	40	30	3	235FF71D1253AGR	(L)	371,00	
125	CS	65	40	30	3	235FF71D1253AHR	(L)	556,60	

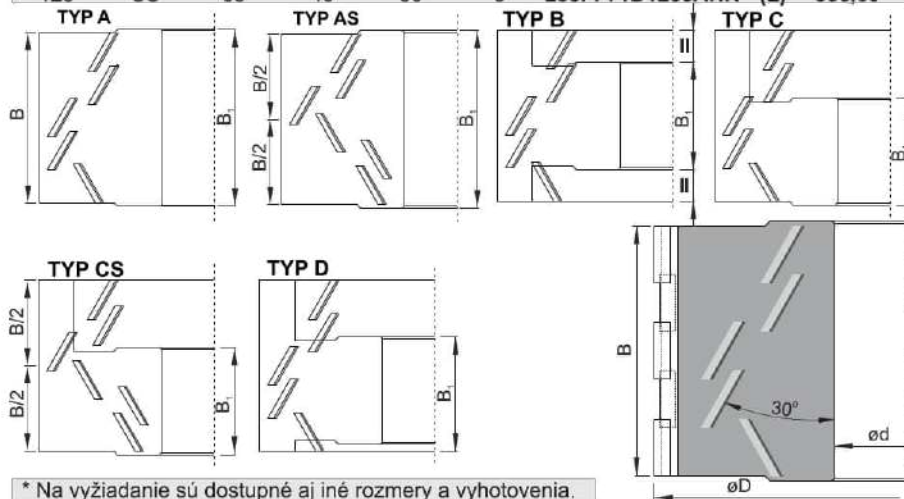

* Na vyžiadanie sú dostupné aj iné rozmery a vyhotovenia.



FF70D ZAROVNÁVACIE FRÉZY PRE OLEPOVAČKY AXIAL 54°							DIA		
ø D	TYP	B	B1	ø d	Z	Nr RH	(L)	€	
100	B	48	25	30	2	235FF70D1002ABR	(L)	617,70	
100	D	48	39	30	2	235FF70D1002ACR	(L)	617,70	
100	B	65	25	30	2	235FF70D1002ADR	(L)	834,60	
100	D	65	39	30	2	235FF70D1002AER	(L)	834,60	

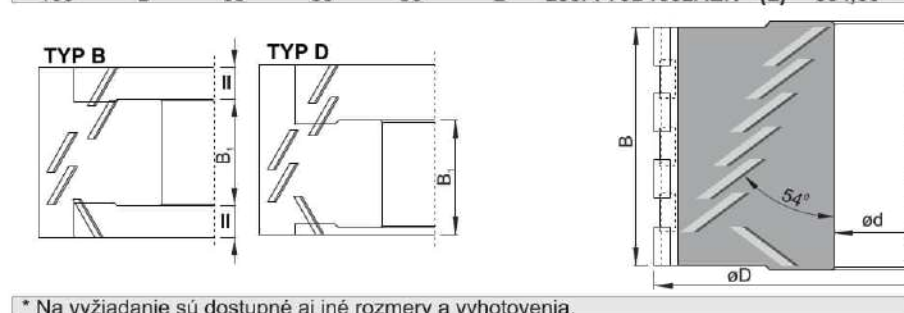

* Na vyžiadanie sú dostupné aj iné rozmery a vyhotovenia.



T070D FRÉZY PRE OLEPOVAČKY S VYMENITELNÝMI ZUBAMI							DIA		
ø D	TYP	B	B1	Z	Nr RH	Nr LH	€		
80	AS	45	53	3	235T070D0803BBR		588,60		
80	B	65	53	3	235T070D0803ABR	235T070D0803ABL	810,80		
100	B	45	41	3	235T070D1003CBR	235T070D1003CBL	588,60		
100	B	54	26	3	235T070D1003FBR	235T070D1003FBL	810,80		
100	D	65	40,5	3	235T070D1003EDR	235T070D1003EDL	810,80		
100	C	65	41	3	235T070D1003ECR	235T070D1003ECL	810,80		
100	C	65	60	3	235T070D1003FCR	235T070D1003FCL	810,80		
125	C	48	40	3	235T070D1253CCR	235T070D1253CCL	688,70		
125	AS	65	40	3	235T070D1253BAR		1 067,00		

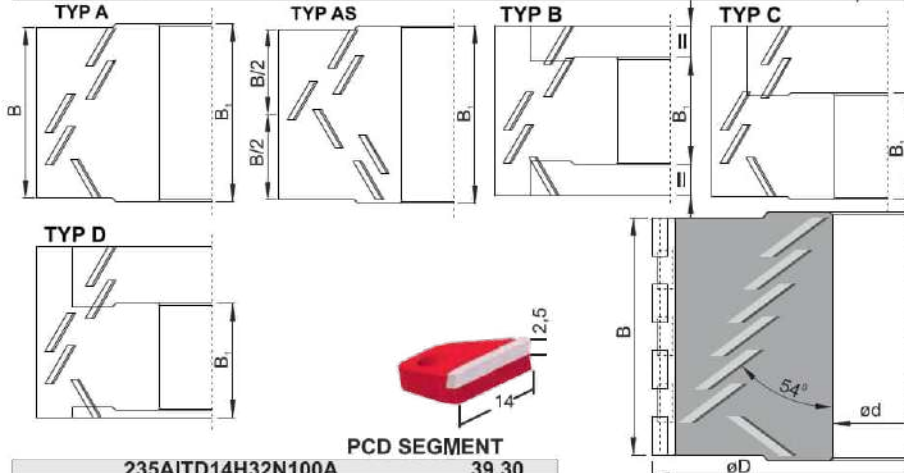

235AITD14H32N100A

39,30



KAPOVACIE PÍLOVÉ KOTUČE STRIEDAVOŠÍKMÉ						HW
ø D	B	b	ø d	Z	Nr	€
100	3,2	2,2	20	20	606FM10002020	47,00
115	2,6	1,8	30	24	606FM11502430	54,50
120	3,2	2,2	20	30	606FM12003020	50,00
125	3,2	2,2	20	20	606FM12502020	48,50
160	3,2	2,2	30	48	606FM16004830	54,80

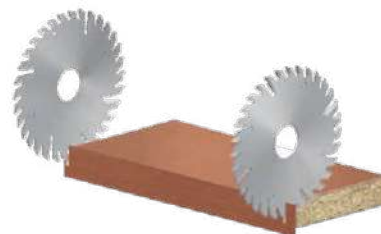

KAPOVACIE PÍLOVÉ KOTUČE ĽAVÉ, PRAVÉ						HW
ø D	B	b	ø d	Z	Nr RH (LH)	€
100	3,2	2,2	20	20	606FP10002020R (L)	37,35
115	2,6	1,8	30	24	606FP11502430R (L)	44,70
120	3,2	2,2	20	30	606FP12003020R (L)	42,30
125	3,2	2,2	20	30	606FP12503020R (L)	46,00
150	3,2	2,2	20	36	606FP15003620R (L)	na dopyt
150	3,2	2,2	30	36	606FP15003630R (L)	37,50
150	3,2	2,2	55	36	606FP15003655R (L)	43,50
150	3,2	2,2	20	48	606FP15004820R (L)	41,25
150	3,2	2,2	30	48	606FP15004830R (L)	39,00
150	3,2	2,2	55	48	606FP15004855R (L)	54,75
180	3,2	2,2	30	36	606FP18003630R (L)	na dopyt
180	3,2	2,2	55	36	606FP18003655R (L)	na dopyt
180	3,2	2,2	60	36	606FP18003660R (L)	na dopyt
200	3,2	2,2	30	48	606FP20004830R (L)	na dopyt
200	3,2	2,2	40	48	606FP20004840R (L)	na dopyt
200	3,2	2,2	80	48	606FP20004880R (L)	na dopyt

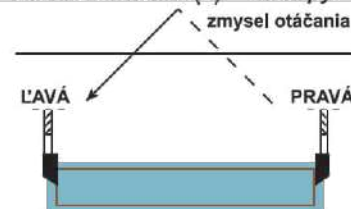

ZAOBĽOVACIE FRÉZY PROFILOVACEJ JEDNOTKY						HW	
TYP	ø D	B	B1	Z	Nr R	Nr L	€
A	56,3	17	16	3	235F420MS017775	235F420MS017776	140,58
B	55,5	13,5	27,5	3	235F420M5614316R	235F420M5614316L	140,58
C	77,4	20,4	16	3	235F480M07720AR	235F480M07720AL	280,00

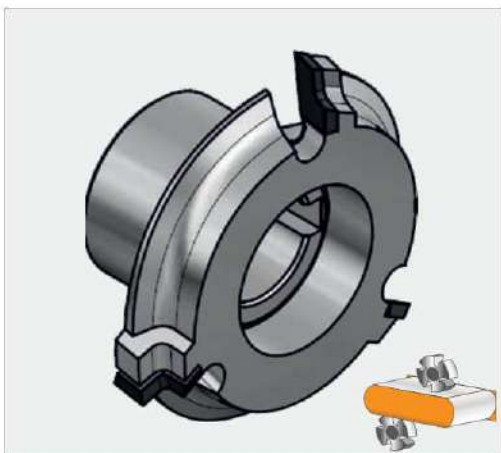
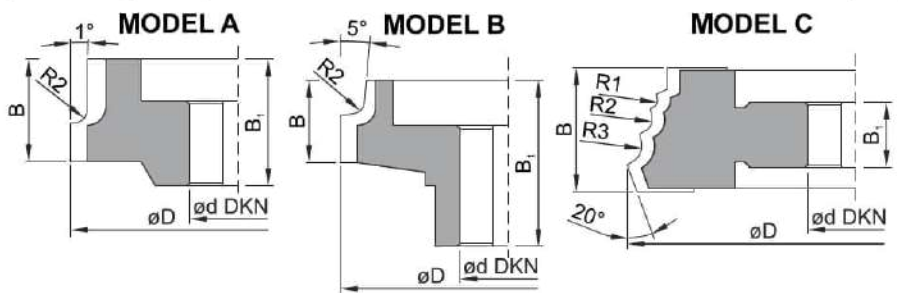

ZAOBĽOVACIE FRÉZY ROUNDVACEJ JEDNOTKY						HW	
TYP	ø D	B	B1	Z	Nr R	Nr L	€
A	70	8	16	4	235F442MS055863	235F442MS055865	280,00
B	55,7	8	25,7	3	235FS13MS053095	235FS13MS053096	225,00

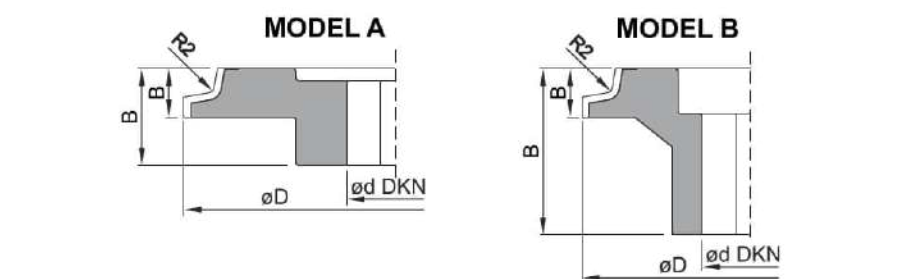

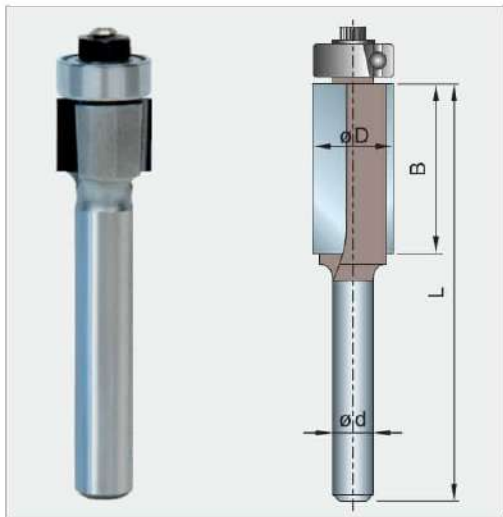

FRÉZA DIA ZAROVNÁVACIA



ø D	B	L	ø D ložisko	ø d	Nr	€
12,7	13	45	12,7	8	235PS03DS009733	96,25

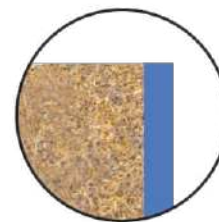

FRÉZA DIA ZRÁŽACIA



ø D	B	L	ø d	Nr	€
32	10	47	8	235PP42D218102R	86,80

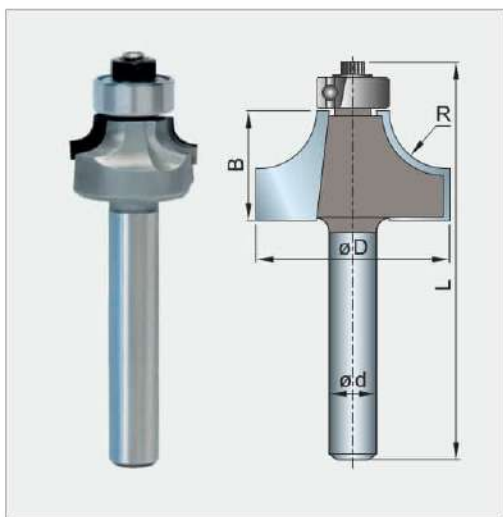
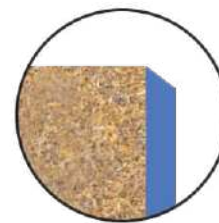

FRÉZA DIA ZAOL'OVACIA



R	ø D	B	L	ø d	Nr	€
2	18	7,5	45	8	235PS03DS019510	111,00

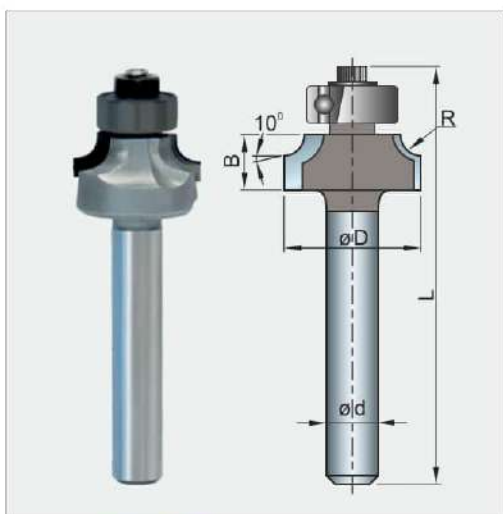
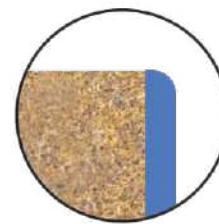

FRÉZA ZAOL'OVACIA

HW



R	ø D	B	L	ø d	Nr	€
2	18	7,5	43	6	23324361500020R	96,65
2	18	7,5	43	8	23324363500020R	80,51
3	20	8,5	44	6	23324361500030R	96,65
3	20	8,5	44	8	23324363500030R	84,44

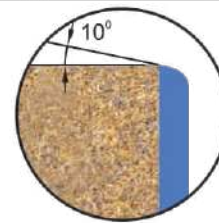

Vyhotovenie frézy s „výbehom“ - 10° a špeciálnou úpravou ložiska garantuje dokonalé zaoblenie hrany s vylúčením poškodenia povrchu dielca.



LEPIDLO EVA TECHNOMELT

Henkel

NATUR	Nr	€
5kg	5140043	33,00
25kg	5140004	123,75

BIELE	Nr	€
5kg	514010-1	60,60
25kg	514010	227,25



TRANSPARENT	Nr	€
5kg	514007-1	62,10
25kg	5140007	232,88

DORUS NATUR	Nr	€
5kg KS 224/2	5140032	32,90€



Vhodné na olepovanie PVC, ABS, polyesteru, melamínu, laminátu, drevených dýh. Tavné lepidlo so širokým rozsahom použitia aj na priebežné linky s variabilnou rýchlosťou.



PUR

Henkel

Balenie	Nr	€ / ks
2kg (nie granulát - patróna)	514009	49,90
16kg (granulát)	5140091	281,80



Vhodné na olepovanie PVC, ABS, polyesteru, melamínu, laminátu, drevených dýh. Aplikáciou PUR lepidla sa zabezpečuje zvýšená vodeodolnosť diela.



LEPIDLO EVA PRE KA65

FESTOOL

Balenie	Farba	Nr	€ / balenie
48ks	čierna EVA	510200060	112,50
48ks	prírodné EVA	510499812	112,50
48ks	biele EVA	510499813	112,50



Univerzálne tavné lepidlo so strednou viskozitou a veľmi dobrou tepelnou stabilitou. Pri lepení vzniká okom neviditeľný veľmi pevný spoj. Vhodné na olepovanie PVC, ABS, polyesteru, melamínu, laminátu, drevených dýh.



LEPIDLO KONTAKTNÉ

CHEMOPRÉN EXTRÉM

Balenie	Nr	€
50ml	507623113	2,21
120ml	507218593	2,42
300ml	5071442311	4,38
1L	5071565687	12,08
4,5L	507239526	49,58



Na kontaktné lepenie s veľmi vysokou pevnosťou. Nie je vhodné na lepenie polystyrénu, teflónu, mäkčeného PVC, PE a PP.





Čistiaci nástrek LC2/30

objem	Nr	€
1L	514LCM300030	8,66-

Chladiaci nástrek LC2/21

objem	Nr	€
1L	514LCM30021	8,66

Ohranný nástrek LC2/40

objem	Nr	€
1L	514LCM30040	8,66-

Separáčny nástrek LC2/10

objem	Nr	€
1L	514LCM30010	8,66-

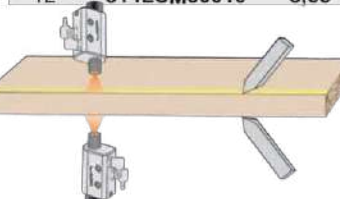
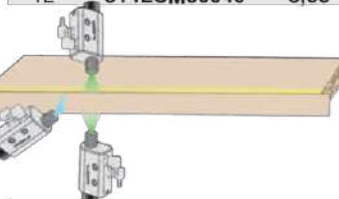
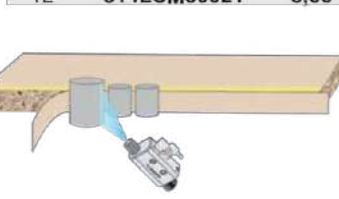
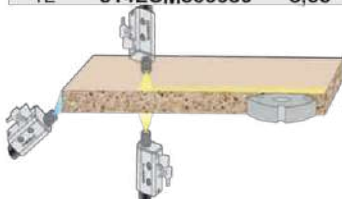

LC2/30 sa používa v závislosti od modelu olepovačky hrán tesne pred leštičkou alebo škrabkou. Použitím LC2/30 sa odstráni predtým použitý separáčny prostriedok a všetky zvyšky lepidla. Ďalšou výhodou použitia LC2/30 je pridaný chladiaci efekt hrán a lepidla.

LC2/21 chladí a čistí zároveň v jednom produkte. Prostriedok sa nanáša pred frézovacími jednotkami na hranu a za prítláčné valce, kde dochádza k ochladzovaniu lepidla a zároveň k čisteniu hrán. Vďaka použitiu chladiacej kvapaliny tu paralelne prebiehajú dva procesy.

LC2/40 sa používa proti usadzovaniu lepidla v rohoch, na prítláčných valcoch a hranách s vysokým leskom, zabraňuje nežiaducemu a rušivému znečisteniu pracovného procesu a zároveň zabraňuje usadzovaniu nových nečistôt. Ohranná fólia sa počas spracovania v stroji neodlepí od okraja.

LC2/10 by sa používa pred frézami na vrchnej a spodnej strane ošetrovaného povrchu. Tento prostriedok zanecháva na spracovávanom materiáli ochranný film, ktorý sa rýchlo odparuje a nezanecháva zvyšky lepidla na ošetrovanom povrchu.

LEŠTIACE KOTUČE RADIÁLNE

rozmer	Nr	€
150x25x50	514LCM30133	56,78



Určené pre SCM, STEFANI, Homag, Brandt, HolzHer, Felder, Biesse, IMA, OTT a iné. Používajú sa na leštenie pásky. Látkové lamely zaisťujú rýchlu absorpciu predtým použitého čistiaceho prostriedku.

LEŠTIACE KOTUČE TANGENCIÁLNE

rozmer	Nr	€
150x25x50	514LCM30082	26,12



Určené pre SCM, STEFANI, Homag, Brandt, HolzHer, Felder, Biesse, IMA, OTT a iné. Sú široko používané od predleštenia až po leštenie do vysokého lesku.

NÁSTREK - SADA

LCM KIT	Nr	€
	514LCM30051K	1300,-

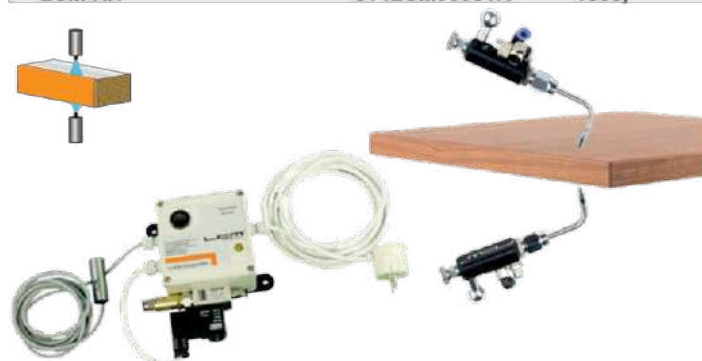

Zabezpečujeme dodatočnú montáž nástreku do olepovačiek. Cena obsahuje dve výzy s dávkovačom, elektroniku, inštaláciu a oživenie.

ČISTIČ LC1/18

čistič	objem	Nr	€
1L	514LCM	6,66	
prázdna piestová nádoba	2L	514LCM30250	99,00

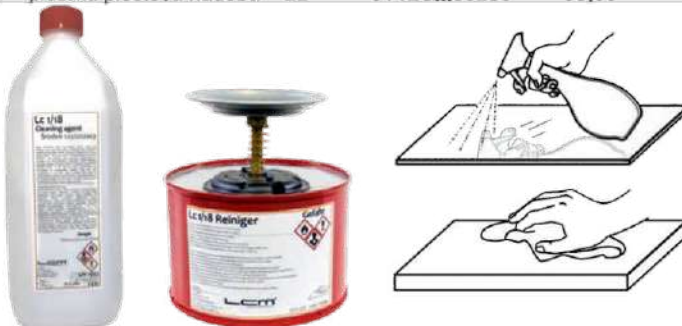

LC1/18 je veľmi účinný, univerzálny čistiaci prostriedok pre moderné a profesionálne ručné čistenie. Použitie na veľmi jemné povrchy, odstraňuje drobné zvyšky lepidla, mastnoty, šmuhy, odtlačky prstov, prach.



RUČNÁ OLEPOVAČKA

Virtuox



šírka	Nr	€
AG 98R 5-40,5 mm	51440025	299,-

šírka	Nr	€
AG 98F 5-50 mm	51440024	265,83



Teplovzdušná olepovačka pre pásky s naneseným lepidlom.



Teplovzdušná olepovačka pre ABS hrany 1mm s naneseným lepidlom.



CONTURO OLEPOVAČKA KA 65-Plus

FESTOOL



model	Nr	€
KA 65-Plus	510576574	2 805,-



Efektívna, jednoduchá a čistá práca, ako aj rýchla výmena farieb vďaka patentovanému systému lepidlových náplní. Perfektná kvalita lepených škár s vysokou pevnosťou vďaka presnému dávkovaniu lepidla.



CONTURO STŔL

FESTOOL

model	€
MFT/3 Conturo-AP pre olepovačku KA 65	966,-



Stôl s doskou s klzným vedením pre použitie olepovačky conturo ako stacionárneho náradia. Možnosť naklápania od 0-47°.



MODULOVÁ FRÉZKA

FESTOOL

model	Nr	€
MFK 700 EQ-Plus	510574369	515,83



Výkonné riešenie frézovania hrán. Dokonalé vedenie frézy zabezpečuje dokonalé opracovanú hranu dielca.





OREZÁVAČ HRÁN RADZI

	Nr	€
radzi varikant	322.0860	55,00

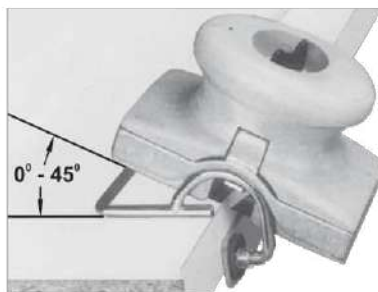

Hoblík na čisté orezávanie olepovaných hrán s plynule nastaviteľným dorazom pre fazetky od 0-45°. Je vhodný na orezávanie plastových hrán do hrúbky 1 mm (aj pre hrany s naneseným tavným lepidlom).



OREZÁVAČ HRÁN PLASTOVÝ

	Nr	€
obojsstranný orezávač	280KBB1M030P	6,58
náhradné nože	280KBB1M031P	10,00



Orezávač jedným prechodom oreže pásku na bočnej ploche dielca obojsstranne. Nastavenie hrúbky orezávača je manuálne, kopírujúc hrúbku dielca.



CIDLINA - VYHLADZOVAČ

FESTOOL

	Nr	€
ZK-HW 45/45	510499749	53,33



zrážanie hrany R1; 1,5; 2

Zrážanie hrán, vytvorenie oblúka a začistenie tenkých hrán a šikmých / skosených hrán (polomery R1; R1,5 a R2 mm). Dlhá životnosť. Vyhovovanie zo spekaného karbidu.



KAPOVAČ KP

FESTOOL

	Nr	€
KP 65/2	510499896	151,67



Jednoduché skracovanie aj hrubších hrán. Presný rez zrážaním vďaka patentovanému jemnému nastaveniu excentera. Obojsstranné podložky stola kapovacieho zariadenia umožňujú rovnomerné skracovanie ľavých a pravých hrán dosky zhora. Funkcie skracovanie zrážaním (pre kruhový stôl) a skracovanie hrán dosiek (koncový rez) v jednom. Na skracovanie plastových hrán s výškou 18–65 mm a hrúbkou 0,5–2,0 mm.



KAPOVAČ AB

Virutex

	Nr	€
RS321S AB	514460005245922	88,33



Pre uhly od 90° do 60°. Čisté a precízne spracovanie zabraňuje poškodeniu panelu. Gilotínový systém umožňuje perfektný rez všetkých hrán z PVC, melamínu, polyesteru, dreva atď. Opätovné ostrenie nožov veľmi vysokej kvality.



KAPOVAČ R

Virutex

	Nr	€
RC221R	514460002100600	48,33

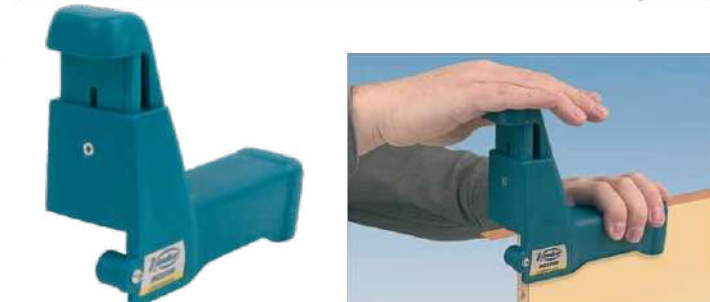

Ručná kapovačka umožňuje perfektné, čisté a vysoko kvalitné zarezanie pásky do hrúbky 3 mm na oboch koncoch dosky. Po zarezaní nie sú potrebné žiadne ďalšie dokončovacie práce. Kapovačka je vybavená otočnými nožmi ktoré sa dajú brúsiť.



PATKA NA HRANY

FESTOOL

pätko so suchým zipsom		filc pre dolešťovanie	
Nr	510495967	19,58 €	510499894
			2,50 €



Ergonomický tvar pre pohodlnú prácu.

Na vyleštenie lesklých hrán v kombinácii s políťou MPA 6000 a doštičkou na ručné brúsenie HSK 80 x 133



HRÚBKOMER

rozsah merania	Nr	€
0-10mm	360A01001	8,17
0-20mm	360A02001	13,75



Spoločné odmeranie hrúbky olepovaného materiálu s citlivosťou 0,1mm.

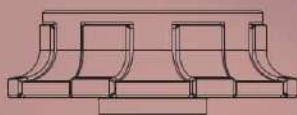
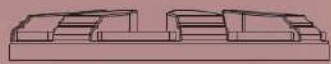
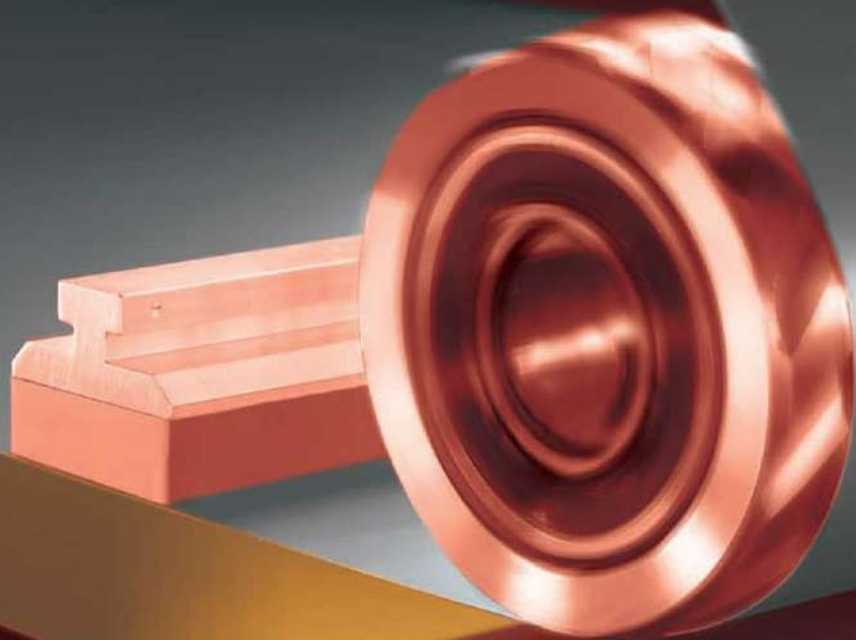

BRÚSENIE



eshop.woodb.sk

BRÚSNY PAPIER 1919+



Zrnitosť	P40	P60	P80	P100-120	P150-220
640x1525	13,08 €	13,08 €	12,71 €	12,71 €	10,21 €
970x1525	19,33 €	19,33 €	18,33 €	18,33 €	17,50 €
970x1900	23,50 €	21,67 €	21,25 €	21,00 €	19,17 €
1115x1900	25,83 €	24,38 €	24,38 €	24,00 €	21,25 €
1115x2150	27,33 €	26,25 €	25,83 €	25,42 €	25,15 €

Výhody

- prémiový produkt najvyššej kvality pre brúsenie dreva,
- minimálne zanášanie vďaka modernej technológii posypu
- vynikajúci výkon a dlhá životnosť
- veľmi vysoký úber s dobrým výsledkom
- výnimočná pevnosť a tuhosť podkladu
- navyše zosilnený pre náročné aplikácie v zrnitostiach od P36 do P80
- nižšie náklady na brúsenie vďaka dlhej dobe životnosti a menej častej výmene pásov

Aplikácia

- kalibrácia povrchov
- hrubé brúsenie masívu a materiálov na báze dreva
- jemné brúsenie masívu, dyhy a materiálov na báze dreva

- Kalibrovanie, hrubé a jemné brúsenie materiálov na báze dreva.

BRÚSNY PAPIER 1918



Zrnitosť	P240	P280	P320	P400	P600
1370x2620	30,25 €	30,25 €	30,25 €	30,25 €	30,25 €
1115x1900	22,10 €	22,10 €	22,10 €	22,10 €	22,10 €
1120x2150	26,50 €	26,50 €	26,50 €	26,50 €	26,50 €

Na objednávku, dodací termín 10 – 15 prac. dní!

Výhody

- nízke zanášanie vďaka otvorenému posypu
- vysoký úber s dobrou kvalitou povrchu
- perfektná kvalita povrchu vďaka prevedeniu TopTec

Aplikácia

- zdrsnenie základu
- matovanie plničov a melaminovej fólie
- medzilakové brúsenie
- jemné brúsenie pred lakovaním
- záverečné brúsenie ako príprava pred lakovaním

- Matovanie plničov a melaminovej fólie, brúsenie pred lakovaním a medzilakové brúsenie, P180 - 600

- PU lak, melaminové fólie, polyesterový lak

BRÚSNY PAPIER 1730



Zrnitosť	P240	P280	P320	P400	P600
1370x2620	25,00 €	25,00 €	25,00 €	25,00 €	25,00 €
1350x3250	28,30 €	28,30 €	28,30 €	28,30 €	28,30 €
1115x1900	20,40 €	20,40 €	20,40 €	20,40 €	20,40 €
1120x2150	22,20 €	22,20 €	22,20 €	22,20 €	22,20 €

Na objednávku, dodací termín 10 – 15 prac. dní!

Výhody

- najvyššia kvalita povrchu pri brúsení v priemyselných lakovniach
- rovnomerný výkon počas celej životnosti produktu
- perfektná kvalita povrchu vďaka prevedeniu TopTec

Aplikácia

- medzilakové brúsenie v priemyselných lakovniach
- záverečné brúsenie ako príprava pred lakovaním

- Brúsenie pred lakovaním a medzilakové brúsenie.

- UV laky, PU laky, melaminové fólie. P180 -800

ODPORUČENÉ TECHNICKÉ PARAMETRE BRÚSENIA

MATERIAL	REZNÁ RÝCHLOSŤ M/S.			RÝCHLOSŤ POSUVU M/MIN.	
	min.	odporúčaná	max.	od.	do.
MASÍV. DREVO	12	20	24	8	18
DÝHA	10	20	24	10	20
PREGLEJKA	10	20	24	10	20
PLNIČ	6	8	10	8	18
LAK	3	8	15	8	18
DTD / MDF	18	26	36	10	20
MINERÁLNA DOSKA	22	26	26	8	16
MELAMINOVÁ FÓLIA	10	12	16	8	18

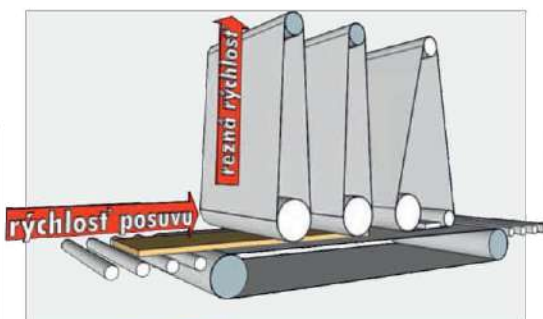

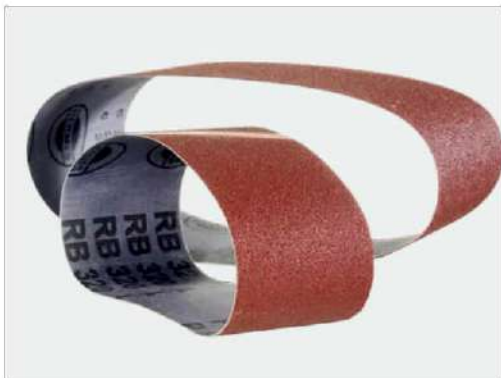

BRÚSNE PÁSY - pre elektrické ručné brúsky

Zrnitosť	Šírka	Dĺžka	Nr	€	Zrnitosť	Šírka x Dĺžka	Nr	€
P40	75	457	3025042122	1,50	P40	100x610	3025042190	2,42
P60	75	457	3025042124	1,46	P60	100x610	3025042191	2,25
P80	75	457	3025042125	1,58	P80	100x610	3025042192	2,21
P100	75	457	3025042126	1,38	P100	100x610	3025042193	1,92
P120	75	457	3025042127	1,38	P120	100x610	3025042194	1,92
P150	75	457	3025042128	1,38	P150	100x610	3025042195	1,92
P40	75	533	3025042182	1,67				
P60	75	533	3025042184	1,71				
P80	75	533	3025042185	1,50				
P100	75	533	3025042186	1,67				
P120	75	533	3025042187	1,50				
P150	75	533	3025042188	1,50				



Na zákazku dodávame zlepené pásy podľa požadovanej dĺžky opásania.



BRÚSNE PÁSY - pre stacionárne pásovú brúsku

Zrnitosť	Šírka	Dĺžka	Nr	€	Zrnitosť	Šírka	Dĺžka	Nr	€
P60	150	6400	3025080624	11,42	P60	150	6800	3025080684	10,67
P80	150	6400	3025080625	11,17	P80	150	6800	3025080685	11,08
P100	150	6400	3025080626	9,92	P100	150	6800	3025080686	10,58
P120	150	6400	3025080627	9,17	P120	150	6800	3025080687	10,17
P150	150	6400	3025080628	8,50	P150	150	6800	3025080688	9,75
P40	150	6500	3025080653	12,08	P40	150	2250	3025087040	6,33
P60	150	6500	3025080654	12,63	P60	150	2250	3025087060	4,50
P80	150	6500	3025080655	10,75	P80	150	2250	3025087080	4,08
P100	150	6500	3025080656	10,33	P100	150	2250	3025087100	4,08
P120	150	6500	3025080657	10,33	P120	150	2250	3025087120	4,08
P150	150	6500	3025080658	10,00					

Na zákazku dodávame zlepené pásy podľa požadovanej dĺžky opásania.

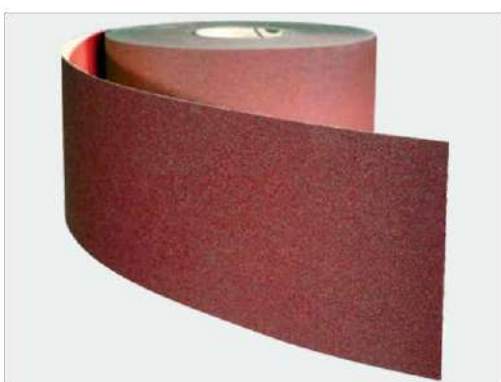

BRÚSNE PÁSY - ROLKY

Zrnitosť	Šírka	Nr	€	Zrnitosť	Šírka	Nr	€
P120	115	611A10301	0,92	P22	150 E18	3025011010	0,96
P80	150	611A5178202	1,42	P40	150 E18	3025011202	2,04
P60	150	611A5185602	1,42	P60	150 E18	3025011204	1,54
P100	150	611A5185801	1,46	P80	150 E18	3025011205	1,29
P120	150	611A5185901	1,42	P100	150 E18	3025011206	1,29
P150	150	611A5186002	1,42	P120	150 E18	3025011207	1,29
P180	150	611A5186101	1,42	P150	150 E18	3025011208	1,33
P240	115	611A5186102	0,82	P220	150 BW33	3025021001	1,79
P280	115	611A5186103	1,13	P240	150 BW33	3025021002	2,04
P150	115	611A59760150	1,00	P280	150 BW33	3025021003	2,04
P180	115	611A59760180	1,00	P320	150 BW33	3025021004	1,92
				P400	150 BW33	3025021006	1,63

Univerzálne flexibilné brusivo na brúsenie dreva, lakov a farieb.



BRÚSNE HÁRKY

Brúsne hárký		papier		plátno		vodovzdorné	
Zrnitosť	Rozmer	Nr	€	Nr	€	Nr	€
P36	230x280	3025051301	0,67	3025052001	0,71		
P40	230x280	3025051302	0,58	3025052202	0,71		
P60	230x280	3025051304	0,46	3025052204	0,63	3025053001	0,50
P80	230x280	3025051305	0,25	3025052205	0,63	3025053002	0,50
P100	230x280	3025051306	0,25	3025052206	0,58	3025053003	0,77
P120	230x280	3025051307	0,25	3025052207	0,58	3025053004	0,54
P150	230x280	3025051308	0,46	3025052208	0,58	3025053005	0,71
P180	230x280					3025053006	0,50
P220	230x280	3025051310	0,58	3025052209	0,58	3025053007	0,46
P240	230x280					3025053008	0,58
P280	230x280					3025053009	0,61
P320	230x280					3025053010	0,53
P360	230x280					3025053011	0,44
P400	230x280					3025053012	0,63
P500	230x280					3025053013	0,50
P600	230x280					3025053014	0,58
P800	230x280					3025053015	0,54
P100	230x280					3025053016	0,58
P150	230x280					3025053019	0,71
P200	230x280					3025053021	0,58
P250	230x280					3025053025	0,46

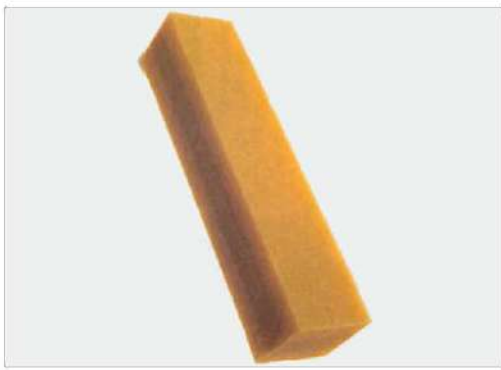

QUICKWOOD STICK

	Nr	€
STICK MAGNUM (50x50x305)	900000653	7,42



STICK vyčistí zanesené pásy a mnohonásobne predĺži ich životnosť.



BRÚSNE HUBKY - pevné



Zrnitosť	Nr	€	Zrnitosť	Nr	€	Zrnitosť	Nr	€
P60	3025055104	0,58	P36 coarse	611A0036	0,67	P36	611A01100	0,83
P80	3025055105	0,58	P60 medium	611A0060	0,62	P60	611A01200	0,80
P100	3025055106	0,58	P80 fine	611A0100	0,67			
P120	3025055107	0,58	P180 superfine	611A0180	0,63			
P150	3025055108	0,58	P150 ultrafine	611A0200	0,63			
P180	3025055109	0,58						
P220	3025055110	0,58						
P240	3025055111	0,58						
P280	3025055112	0,58						
P320	3025055113	0,58						

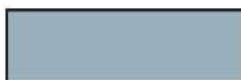

BRÚSNE HUBKY - ohybné



Zrnitosť	Rozmer	Nr	€
P60	120x95	3025055124	0,58
P80	120x95	3025055125	0,58
P100	120x95	3025055126	0,58
P120	120x95	3025055127	0,58
P150	120x95	3025055128	0,58
P180	120x95	3025055129	0,58
P220	120x95	3025055130	0,58
P240	120x95	3025055131	0,58

Vhodné pre brúsenie tvarovo zložitých povrchov.



BRÚSNE RÚNA - vlies



Zrnitosť		Nr	€
P00	biele	611A8540011	1,83
P80	hnedé	611A8542922	2,25
P100	zelené	611A8544923	1,00
P180	červené	611A8545911	1,04
P320	červené	611A8546932	0,88
P800	šedozeleň	611A8548712	1,13
P1000	žlté	611A8549913	0,96

Vhodné pre brúsenie a dolešťovanie tvarových plôch.



BRÚSNY MOLITAN



Zrnitosť	Nr	€
P150	611A218994760150	43,33
P220	611A218994760220	44,58
P240	611A218994760240	39,98
P320	611A218994760320	39,98
P600	611A218994760600	39,98

Priemyselné balenie – 25 m = 200 útržkov pre efektívne brúsenie tvarových plôch.



BRÚSNA VLNA - OCEĽOVÁ



Zrnitosť		Nr	€
P000	200g	4486095	4,71
P00	200g	4486096	4,58
P0	200g	4486097	4,54
P1	200g	4486098	4,42



Vhodné pre brúsenie povrchov tvarovo zložitých dielcov /úchytky ,ozdoby.. / po povrchovej úprave.



BRÚSNE PÄTKY s mechanickým upínaním brusiva								
pätka s rukoväťou	€	pätka plochá	€	ručná 2K-Plus	€			
100x220	328700128	1,75	160x85	328307950	3,42	93x230	4485890	10,38



Pätky sú určené na manuálne plošné brúsenie s možnosťou mechanického upnutia brúsneho papiera.



BRÚSNE PÄTKY na suchý zips - pravouhlé								
pätka HSK	€	pätka HSK-STF	€	pätka HSK-A	€			
80x133	510495967	19,58	46x178	510583129	12,70	80x133	510496962	45,85



Brúsne pätky pre upnutie brusiva na suchý zips.

Pätka napojená na odsávanie.



BRÚSNE PÄTKY na suchý zips - okrúhle								
pätka 2K-Plus	€	pätka HSK-D	€	pätka do rohov 2K-Plu	€			
ø 125mm	4485894	9,54	ø 150 W	510495965	17,10	ø 150 H	510495966	17,50
				95x90	4485884	7,75		



Brúsne pätky pre upnutie brusiva na suchý zips. Brúsne kotúče zahnete po bokoch.

Delta tvar brusiva.



DUPLEX PATKA		
Brúska Festool LS 130 EQ plus	Nr	€
	510567850	463,33
Typizovaná DUPLEX pätka	€	31,67
Zákazková DUPLEX pätka	€	44,00

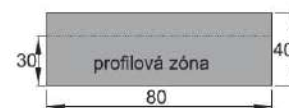
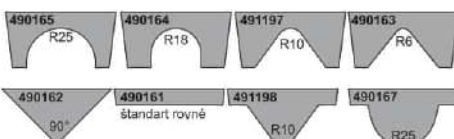

DUPLEX pätka, dodávaná v štandardných profiloch umožní tvarové brúsenie v kombinácii s duplex strojom.

Vyprofilujeme zákazkové duplex pätky podľa individuálnych požiadaviek. Cena nie je závislá od tvaru pätky.



MERLIN VARIO PRO		
pätka vario pro	Nr	€
	34410VP08502	42,40
brusivo P120	344085K120	0,39
brusivo P180	344085K180	0,39
brusivo P220	344085K220	0,39



VARIO PRO je ručná brúsna pätka, ktorá sa po uvoľnení aretačnej skrutky predtvaruje do požadovaného profilu.

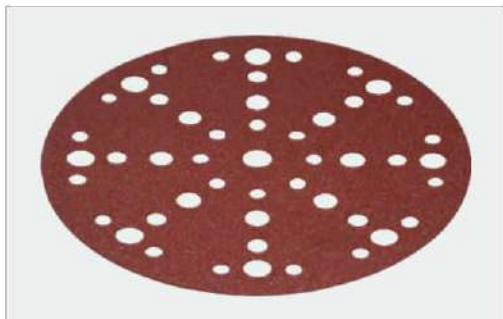

BRÚSNE KOTUČE RUBIN 2

FESTOOL

Zrnitosť'	ø D90		ø D125		ø D150	
	Nr	€	Nr	€	Nr	€
P40	510499077	0,48	510499093	0,71	510575186	0,79
P60	510499078	0,47	510499094	0,75	510575187	0,92
P80	510499079	0,43	510499095	0,75	510575188	0,83
P100	510499080	0,40	510499096	0,58	510575189	0,68
P120	510499081	0,38	510499097	0,58	510575190	0,68
P150	510499082	0,38	510499098	0,63	510575191	0,58
P180	510499083	0,38	510499099	0,58	510575192	0,60
P220	510499084	0,38	510499100	0,58	510575193	0,58

Vysokovýkonné brusivo pre prípravné práce spojené s brúsením pred lakovaním, olejovaním.

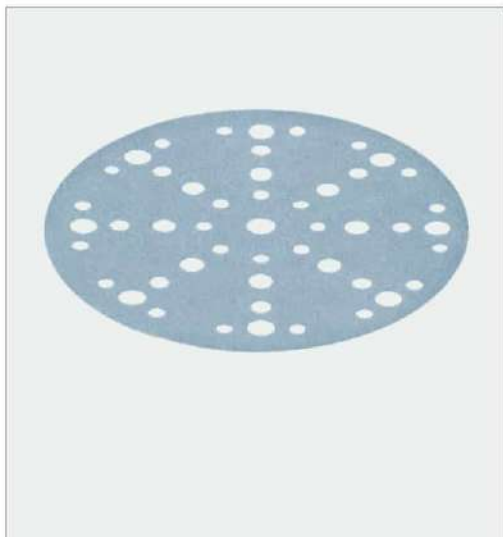

BRÚSNE KOTUČE GRANAT

FESTOOL

Zrnitosť'	ø D90		ø D125		ø D150	
	Nr	€	Nr	€	Nr	€
P40	510497363	0,48	510497165	0,75	510575160	0,75
P60	510497364	0,44	510497166	0,71	510575161	0,75
P80	510497365	0,42	510497167	0,65	510575162	0,71
P100	510497366	0,37	510497168	0,57	510575163	0,63
P120	510497367	0,36	510497169	0,57	510575164	0,63
P150	510497368	0,36	510497170	0,57	510575165	0,62
P180	510497369	0,36	510497171	0,57	510575166	0,62
P220	510497370	0,36	510497172	0,57	510575167	0,63
P240			510497173	0,58	510575168	0,63
P280			510497174	0,57	510575169	0,63
P320			510497175	0,57	510575170	0,60
P360			510497176	0,58	510575171	0,60
P400			510497177	0,58	510575172	0,53
P500			510497178	0,58	510575173	0,53
P800			510497179	1,00	510575174	1,00
P1000			510497180	1,04	510575175	1,25
P1200			510497181	1,04	510575176	1,25
P1500			510497182	0,77	510575177	1,25

Vysokovýkonné brusivo pre spracovanie veľmi tvrdých podkladov (akryl, tmeľ, plnivo).

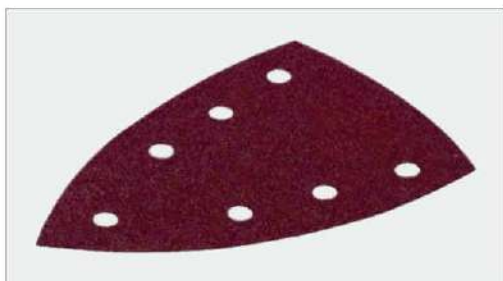

BRÚSNE DELTA RUBIN 2

FESTOOL

Zrnitosť'	STF DELTA/7		STF V93/6	
	Nr	€	Nr	€
P40			510499161	0,39
P60	510499134	0,75	510499162	0,42
P80	510499135	0,54	510499163	0,42
P100	510499136	0,42	510499164	0,33
P120	510499137	0,42	510499165	0,33
P150			510499166	0,42

Vysokovýkonné brusivo pre prípravné práce spojené s brúsením pred lakovaním, olejovaním.



BRÚSNE HÁRKY RUBIN 2

FESTOOL

Zrnitosť'	80x133mm		93x178mm		115x228mm	
	Nr	€	Nr	€	Nr	€
P40	510499046	0,50				
P60	510499047	0,48	510499062	0,58	510499031	0,67
P80	510499048	0,47	510499063	0,55	510499032	0,67
P100	510499049	0,38	510499064	0,50	510499033	0,58
P120	510499050	0,38	510499065	0,48	510499034	0,58
P150	510499051	0,38				

Vysokovýkonné brusivo pre prípravné práce spojené s brúsením pred lakovaním, olejovaním.



BRÚSNE HÁRKY GRANAT

FESTOOL

Zrnitosť'	80x133mm	
	Nr	€
P60	510497118	0,54
P80	510497119	0,46
P120	510497120	0,38
P180	510497122	0,38
P240	510497124	0,38
P320	510497125	0,38

Vysokovýkonné brusivo pre spracovanie veľmi tvrdých podkladov (akryl, tmeľ, plnivo).



BRÚSNE NÁRADIE

FESTOOL

ES-ETSC	ES-ETS 125	ROTEX RO 90 DX	ROTEX RO 125	ROTEX RO 150
ETSC 125	ETS EC 125/3	ETS EC 150/3	ETS EC 150/5	ETS 125
ETS 150/3	ETS 150/5	RTSC 400	RTS 400	

celý sortiment
na eshope
 woodb.sk

LEŠTIACE TANIERE **FESTOOL**

pre Rotex RO 90 DX	€	pre Rotex RO 125 FEQ	€
ø 80 510495625	29,17	ø 115 510492128	19,17



pre Rotex RO 150 FEQ	€	M14 na RAP 150	€
ø 135 510496151	21,33	ø 125 510488342	30,42



Funkcia FastFix - na upnutie leštiaceho príslušenstva.

BRÚSNE TANIERE **FESTOOL**

mäkký - D150 na ROTEX	€	D125 na ETS	€
ø 150 510202461	46,67	supermäkký 510492282	41,25
		mäkký 510492280	45,83



mäkký - D150 na ETS/LEX	€	D150 na ETS/LEX	€
ø 150 510202458	53,33	tvrdý 510202460	47,50



Funkcia FastFix - na upnutie leštiaceho príslušenstva. Mäkké vyhotovenie. Suchý zips odolný proti vysokým teplotám.

PRÍPRAVNÉ LEŠTENIE

objem	Nr.	€	ø D	Nr.	€
0,5lit	510202048	24,17	125	510201995	9,58
			125 zvltnená	510201996	11,24
			150	510201997	13,17
			150 zvltnená	510201998	15,85



Zjednodušujú leštenie. Vhodné na všetky lakované povrchy, laky VOC.

Špongia oranžová stredná na predleštenie pri odstraňovaní chýb laku.

FINÁLNE LEŠTENIE

objem	Nr.	€	ø D	Nr.	€
0,5lit	510202050	xx	80	510202001	6,25
			80 zvltnená	510202002	7,82
			150	510202005	11,67
			150 zvltnená	510202006	14,54



Čistí, odstraňuje stopy používania na starom laku a dodáva vysoký lesk. Vhodné na opravné lakovanie.

Špongia modrá (stredne jemná) Na odstránenie mikroškrabancov v laku.

LEŠTENIE VYSOKÉHO LESKU

objem	Nr.	€	ø D	Nr.	€
0,5lit	510202051	24,17	125	510202011	8,75
			125 zvltnená	510202012	11,28
			150	510202013	16,89
			150 zvltnená	510202014	25,00



Leštiace prostriedky Festool zjednodušujú leštenie.

Špongia biela jemná - slúži na predleštenie a finiš.

ÚPRAVA POVRCHU

objem	Nr.	€	ø D	Nr.	€
0,5lit	510202053	11,58	150 zvltnená	510202380	18,76



Na zvlhčenie brúsnych ružíc a zabraňuje ich predčasné zanášanie. Na odstraňovanie zvyškov leštidla.

Špongia čierna na odstraňovanie zvyškov leštiacich prostriedkov

LEŠTENIE POVRCHU

ø D	Nr.	€	ø D	Nr.	€
150 tvrdá	510488348	6,17	150	510202046	12,50
150 mäkká	510488347	5,50			



Na predleštenie minerálnych materiálov, akrylátového skla a lakov.

Mimoriadne homogénna štruktúra usne pre rovnomerný výsledok leštenia.

DOKONČOVACIE PROSTRIEDKY

Nr.	€	Nr.	€
škrabka 510497525	60,00	MPA utierka 2ks 510205732	27,76



Vyhľadzoč lak - odstraňovanie zrníčok prachu pomocou mierneho zaoblenia na prednej hrane čepele.

Utierka - Rozprašovací konzervačný prostriedok a čistič Finish sa postarajú o ligotavé výsledky. Na odstraňovanie zvyškov leštidla.



QUICKWOOD MODEL F3

pneumatická ručná brúska - model F3 (neobsahuje nosič)		Nr	€
		270QF3	558,00
radiálny nosič		Nr	€
		270Q56200000	85,00
		<i>cena s osadením brusiva</i>	
kruhový nosič		Nr	€
		270Q58300000	66,00
		<i>cena s osadením brusiva</i>	



F3 možno osadiť radiálnym brusivom rôznej zrnitosti a rozmerov (B-50mm). Pre intenzívne tvarové brúsenie.



F3 možno osadiť kruhovým brusivom rôznej zrnitosti a rozmerov (180,300). Pre jemné tvarové brúsenie.

F3 je ručné profesionálne brúsiace zariadenie, ktoré je možné osadiť širokým sortimentom brúsnych nástrojov s radiálnym, alebo kruhovým uložením. Napájané tlakovým vzduchom (0,6MPa).



QUICKWOOD PROFIL

D _{max}	B	ø d	Nr	€	D _{max}	B	ø d	Nr	€
220	50	30	270Q50	79,00	220	75	30	270Q75	98,00
					<i>cena s osadením brusiva</i>				

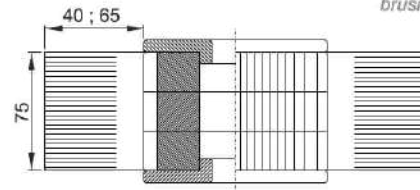
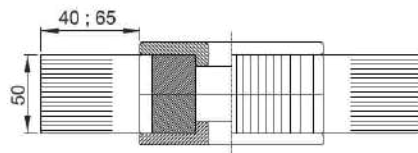

Plastový nosič nástroja (Nr.270QA001001 á 5,10€) je na šírku nastaviteľný a vybavený jednou redukčnou prírubou (Nr.301B2451201 á 17,50€). Nástroj je možné použiť do spodnej frézy, alebo osadený do HSK hriadeľa (Nr.232WF242 á 170€) pre CNC. Nástroj je osadený podľa zákaznickej požiadavky brusivom Quickwood vo zvolenom rozmere a zrnitosti, bez vplyvu na cenu.



QUICKWOOD VÝPLŇ

ø D	B	Nr	€	ø D	B	ø d	Nr	€	
200	75	301BQHSK	298,00	200	75	30	301BQ	188,00	
				<i>cena s osadením brusiva</i>				<i>cena s osadením brusiva</i>	

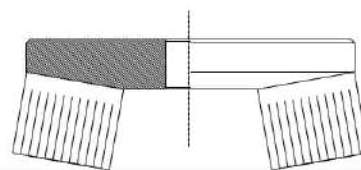
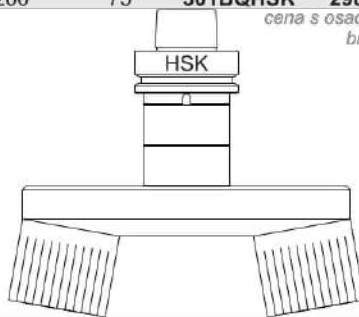

Nosič tela z Al je vyhotovený univerzálne pre brusivo Quickwood šírky max. 75 mm. Nástroj je možné použiť do spodnej frézy, alebo osadený do HSK hriadeľa pre CNC. Nástroj je osadený podľa zákaznickej požiadavky brusivom Quickwood vo zvolenom rozmere a zrnitosti, bez vplyvu na cenu.

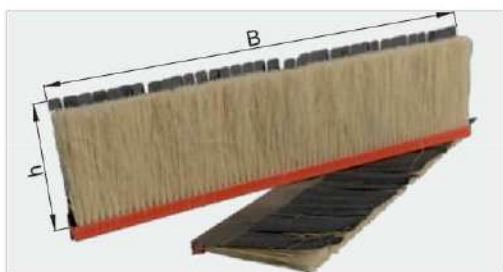

RADIÁLNE BRUSIVO QUICKWOOD

Zrnitosť	B x h rozmer 50x40		B x h rozmer 50x65		B x h rozmer 75x40		B x h rozmer 75x65	
	Nr	€	Nr	€	Nr	€	Nr	€
P80	270QR050040080	1,49	270QR050065080	1,56	270QR075040080	2,35	270QR075065080	2,41
P100	270QR050040100		270QR050065100		270QR075040100		270QR075065100	
P120	270QR050040120		270QR050065120		270QR075040120		270QR075065120	
P150	270QR050040150		270QR050065150		270QR075040150		270QR075065150	
P180	270QR050040180		270QR050065180		270QR075040180		270QR075065180	

Plastový nosič je osadený 20kusmi radiálnych brúsnych segmentov Quickwood.



KRUHOVÉ BRUSIVO QUICKWOOD

Zrnitosť	rozmer ø 300		rozmer ø 180	
	Nr	€	Nr	€
120	270QK300120	5,97	270QK180120	3,57
150	270QK300150		270QK180150	
180	270QK300180		270QK180180	
240	270QK300240		270QK180240	
320	270QK300320		270QK180320	



(5ks brúsnych tanierov)

(10ks brúsnych tanierov)



TECNOFLEX

zrornosť	B x D x d	Nr	€	B x D x d	Nr	€
P80	50x160x8	270TCFG160508080	47,80	70x160x8	270TCFG160758080	51,50
P100	50x160x8	270TCFG160508100	41,30	70x160x8	270TCFG160758100	51,50
P120	50x160x8	270TCFG160508120	41,30	70x160x8	270TCFG160758120	51,50

zrornosť	B x D x d	Nr	€	B x D x d	Nr	€
P80	100x160x8	270TCFG161008080	55,50	100x210x30	270TCF21010030080	72,50
P100	100x160x8	270TCFG161008100	55,50	100x210x30	270TCF21010030100	72,50
P120	100x160x8	270TCFG161008120	55,50	100x210x30	270TCF21010030120	72,50
P180				100x210x30	270TCF21010030180	72,50

Brúsený kotúč so stopkou $\varnothing 8$ pre účinné tvarové brúsenie, vhodný do ručnej vrtáčky. Jednorázové.

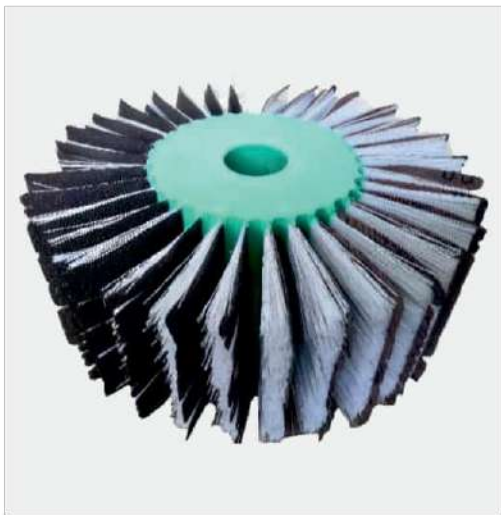

KARTÁČOVÝ BRÚSNY KOTUČ TECNOFLEX

zrornosť	B	$\varnothing D$	$\varnothing d$	Nr	€
P80	50	160	8	270TCFG160508080	47,80
P100	50	160	8	270TCFG160508100	41,30
P120	50	160	8	270TCFG160508120	47,80

zrornosť	B	$\varnothing D$	$\varnothing d$	Nr	€
P80	75	160	8	270TCFG160758080	51,50
P100	75	160	8	270TCFG160758100	51,50
P120	75	160	8	270TCFG160758120	51,50

zrornosť	B	$\varnothing D$	$\varnothing d$	Nr	€
P80	100	160	8	270TCFG161008080	55,50
P100	100	160	8	270TCFG161008100	55,50
P120	100	160	8	270TCFG161008120	55,50

Jednorázová brúsna kefa s priechodným otvorom s napevno osadenými štetinami, ktoré umožňujú brúsenie tvarových obrobkov. Kefa je určená predovšetkým na dobrosovanie a vyhladzovanie povrchu po prvom brúsení, máčaní atď. Upínací otvor s priemerom 30 mm.



BRÚSNA KEFA ČELNÁ

zrornosť	B	$\varnothing D$	$\varnothing d$	Nr	€
P120	35	130	10	270TAPP1303510120	41,67
P120	45	130	10	270TAPP1304510120	41,67
P150	35	130	10	270TAPP1303510150	41,67
P150	45	130	10	270TAPP1304510150	41,67



Jednorázová brúsna kefa so stopkou, s napevno osadenými štetinami, ktoré umožňujú brúsenie tvarových obrobkov. Kefa je určená predovšetkým na dobrosovanie a vyhladzovanie povrchu po prvom brúsení, máčaní atď. Upínací otvor s priemerom 10 mm.



LAMELOVÝ KOTUČ

zrornosť	B x D x d	Nr	€	B x D x d	Nr	€
P40	10 x 20 x 6	611A92010040	1,96	20 x 20 x 6	611A92020040	2,25
P60	10 x 20 x 6	611A92010060	2,25	20 x 20 x 6	611A92020060	2,25
P80	10 x 20 x 6	611A92010080	1,96	20 x 20 x 6	611A92020080	2,21
P120	10 x 20 x 6	611A92010120	1,96	20 x 20 x 6	611A92020120	1,96

zrornosť	B x D x d	Nr	€	B x D x d	Nr	€
P60	15 x 25 x 6	611A92515060	2,25	15 x 30 x 6	611A93015060	2,48
P80	15 x 25 x 6	611A92515080	2,21	15 x 30 x 6	611A93015080	2,38
P120	15 x 25 x 6	611A92515120	2,33	15 x 30 x 6	611A93015120	2,48

zrornosť	B x D x d	Nr	€	B x D x d	Nr	€
P60	20 x 40 x 6	611A94020060	2,58	20 x 50 x 6	611A95020060	2,67
P80	20 x 40 x 6	611A94020080	2,54	20 x 50 x 6	611A95020080	2,67
P120	20 x 40 x 6	611A94020120	2,33	20 x 50 x 6	611A95020120	2,67

Lamelové brúsne kotúče so stopkou pre jemné dobrosovanie plôch s malým zakrivením. Správna voľba zrornosť, priemeru kotúča a otáčok ovplyvňuje obrobeneý povrch.





HOBBYSAND		Nr RED		Nr BISA		€
ø D	ø d	B				
150	30	30	270N1001503030R	270N1201503030B		25,50
150	30	40	270N1001504030R	270N1201504030B		34,00
150	30	50	270N1001505030R	270N1201505030B		41,90

profilová zóna max. 25mm	pre tvrdé dreva	pre mäkké dreva
príruba	Nr 270F8040	€ 17,74

Remeselný brúsny systém. Brúsne hlavy s plnou brúsnou zmesou. Obrusovaním sa mení priemer nástroja. Maximálne otáčky 1500 ot./min. Používané na spodných frézovačkách. Vhodné pre brúsenie dreva. Podľa priloženého návodu si môžete do polotovaru vybrúsiť svoj tvar brúsneho profilu.



ECOFLEX VÝPLŇ		fixovač		sada segmentov	
nosič	€	fixovač	€	6ks	€
270A204660	128,60	270A208660	35,60	270A202601	92,80

Brúsny systém pre presné tvarové brúsenie povrchov. Univerzálny nosič je možné osadiť ľubovoľnými tvarovými segmentami. Odporúčajú sa ot. 1.500, max. 3000 ot./min.

Fixovač je univerzálny pre všetky druhy brúsnych segmentov a slúži na zaistenie ich polohy v nosiči.

Sada profilových segmentov (6 ks), osadená brusivom ľubovoľnej zrnitosti je dodávaná podľa DXF, DWG súboru profilu, alebo podľa dodanej frézovanej vzorky.



ECOFLEX HRANA		medzikus		sada segmentov	
základ	€	medzikus	€	6ks	€
270A204661	57,2	270A208660B	50,00	270A2026010	78,60

Základ je vyhotovený pre univerzálne osadenie brúsnych segmentov s možnosťou jeho rozširovania nadstavením.

Medzikus je kombinovaný so základom a umožňuje rozširovanie brúsnej hlavy podľa výkovej požiadavky.

Sada profilových segmentov (6 ks) osadená brusivom ľubovoľnej zrnitosti je dodávaná podľa DXF, DWG súboru profilu, alebo podľa dodanej frézovanej vzorky.

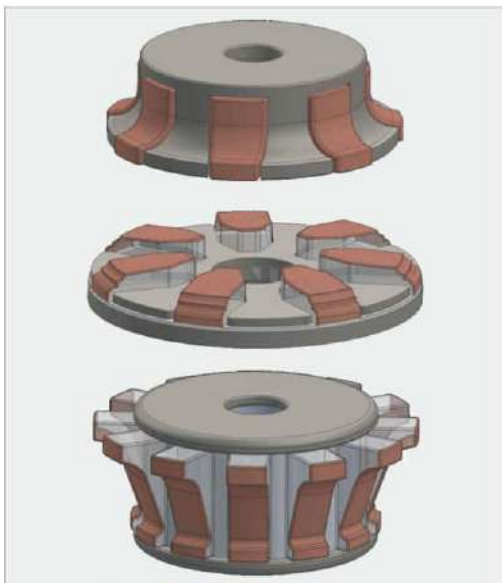

PROFISAND PROFIL		Brúsna hlava €		Náhradný segment €	
B	30~80	cena na vyžiadanie	cena na vyžiadanie	cena na vyžiadanie	cena na vyžiadanie
Brúsna hlava obsahuje 7 tvarových segmentov.					
B	30	cena na vyžiadanie	cena na vyžiadanie	cena na vyžiadanie	cena na vyžiadanie
Brúsna hlava obsahuje 1 tvarový segment.					
B	30~80	cena na vyžiadanie	cena na vyžiadanie	cena na vyžiadanie	cena na vyžiadanie
Brúsna hlava obsahuje 1 tvarový pás-strip.					

Zákazkový priemyselný brúsny systém s konštantným priemerom nástroja pracuje pri max. otáčkach 1500 ot./min. Výhodou je rýchla výmena brúsnych segmentov, na ktorých je vlepene brusivo so zrnitosťou v závislosti na druhu obročku. Uvedené ceny sú nezávislé na profile.



DRÁSACÍ KOTUČ



	ø D	ø d	B	Nr	€
Drásací kotuč P60	140	M14	50	611A7068060	35,17
Drásací kotuč P80	140	M14	50	611A7068080	35,17
Drásací kotuč P120	140	M14	50	611A7068120	35,42
Unášač			8x50/M14	328108510	0,75



Vhodný pre vrtačky a uhlové brúsky.



CENTRIFUGAL



valec	B x D x d	B x D x d	B x D x d	B x D x d
Nr	270TCREC10005020	270TCREC12008030	270TCREC10010030	270TCREC12012030
€	112,-	159,-	159,-	189,-

brúsne pásy zlepené	Nr	Nr	Nr	Nr
zrnitosť 100			270TCNT1003140100	270TCNT1203780100
120	270TC050100120	270TCNT1202521200		
150			270TCNT1003140150	
220	270TC220100220	270TCNT1202522200		
€	3,80	4,20	3,60	4,50

CENTRIFUGAL sú brúsne hlavy opásané zlepeným brúsnym pásmom. Špeciálny profil pogumovania brúsneho valca umožňuje dokonalé brúsenie dielcov na spodnej frézovačke, alebo CNC.



BRÚSNY VALČEK NA SPODNÚ FRÉZU

ø D	ø d	B	Nr	€
45	30	90	302570491105	27,50
60	30	90	302570491106	32,29
90	30	90	302570491107	54,08
120	30	90	302570491108	84,17

Sada gúm na brúsný valček ø D Nr €
 Ø 45 – 120 mm 302570491100 13,75



Brúsný valec s excentrickým upínaním brúsneho pásu. Výhodou je možnosť použitia ľubovoľného brusíva, vopred na rozmer naformátovaného. Valec, vyhotovený z plastu je vhodné opláštiť zmäkčovacou pryžou.



ROTAČNÁ RAŠPĽA

čepel	označenie	priemer	Nr	€
1,5		125x22,2mm	33312515	21,58
2,0		125x22,2mm	33312520	20,79
2,5		125x22,2mm	33312525	20,79
4,0		125x22,2mm	33312540	30,25



Účinná rašpľa pre uhlové brúsky. Vhodné pre odstraňovanie starých náterov, tvarovanie a zdrsňovanie povrchov dreva.

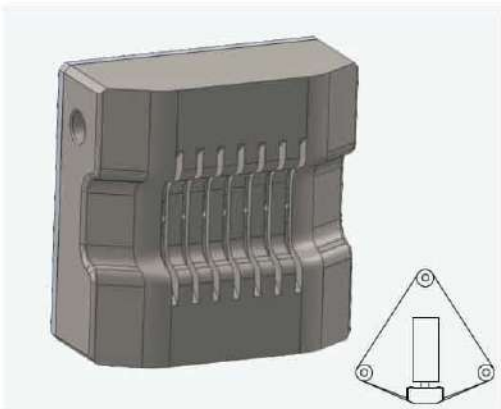

PROFISAND PAD BLOCK

zákazková päťka BLOCK 280,-	zákazková päťka CLIP 280,-	zákazková päťka HOMAG 280,-
--------------------------------	-------------------------------	--------------------------------

Cena nezávislá na tvare päťky.

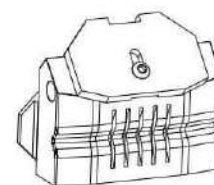
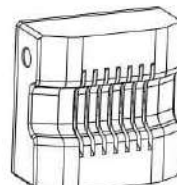
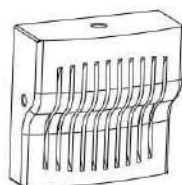

Vyhotovujeme zákazkové brúsne päťky pre rôzne druhy upínaní.



DRÁSACÍ HOBLÍK



	ø D	B	Nr	€
Makita model 9741			5139741	365,00
Plastový drásací valec	80	120	51304438	76,67
Oceľový drásací valec	80	120	51365648	75,83



V základnej výbave je drásací hoblík osadený plastovým valcom



KARTÁČOVÁ BRÚSKA



	ø D	B	Nr	€
Fartools Rex 125B	120	20-100	448F115027	137,50
Zirkónová brúsna kefa				
B-100 mm zrnitosť 120	448F110864	32,08€		
Bavlnená kefa				
B-100 mm zrnitosť 120	448F110867	34,50€		



- jemné brúsenie
- satínovanie povrchov

- leštenie

Brúsna syntetická kefa

B-100 mm 448F110863 17,67€
zrnitosť 120



- jemné brúsenie
- satínovanie

Brúsna lamelová kefa

B-100 mm 448F110868 22,46€
zrnitosť 80



- brúsenie
- odstraňovanie farieb

Pásová kefa

B-100 mm 448F110869 22,46€
zrnitosť 80



- brúsenie profilových
materiálov

Kefa zo syntetických vlákien

B-100 mm 448F110873 15,67€



- čistenie
- kartáčovanie

Nylonová kefa

B-100 mm 448F110886 49,00€
zrnitosť 80



- odstraňovanie farieb
- štruktúrovanie dreva

Kefa z karbidu kremika

B-100 mm 448F110888 33,75€



- brúsenie ; - príprava
kovových plôch na zváranie

Kefa z umelohmotných vlákien

B-100 mm 448F110889 22,46€



- čistenie ; - kartáčovanie
- kartáčovanie umelých trávnikov

Nylonová kefa

B-100 mm 448F110915 53,33€



- čistenie
- kartáčovanie

Kefa s brúsnymi pásmi

B-100 mm 448F110916 24,42€



- brúsenie profilových
materiálov

Brúsna lamelová kefa

B-100 mm 448F110917 24,42€



- brúsenie

Kovová drôtená kefa

B-100 mm 448F110874 40,42€



- brúsenie ; - čistenie dreva
- odrezávanie ; - odstránenie farieb

Mosadzná drôtená kefa

B-100 mm 448F110885 28,25€



- odstránenie farieb
- odstránenie hrdze

VZDUCH



eshop.woodb.sk

INTERIÉROVÉ ODSÁVAČE MALÉ

	Nr	€		Nr	€
FT200	180021	659,00	FT202	1800211	833,00

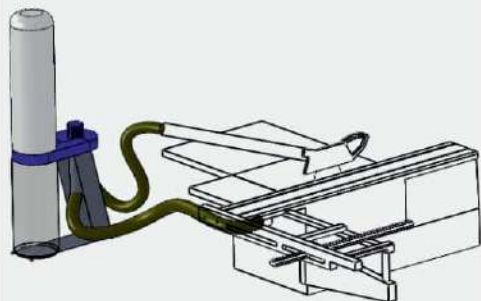

ods. kapacita	1560 m ³ /hod
hrdlo ø	125 mm
výkon	1,1 kW



ods. kapacita	1760 m ³ /hod
hrdlo ø	150 mm
výkon	1,1 kW

Odsávače sú určené na pripojenie jedného drevoobrábacieho stroja s možnosťou osadenia rozvojky s hradítkom.

INTERIÉROVÉ ODSÁVAČE STREDNÉ

	Nr	€		Nr	€
FT400	180042	1 632,00	FT403	180043	1 986,00

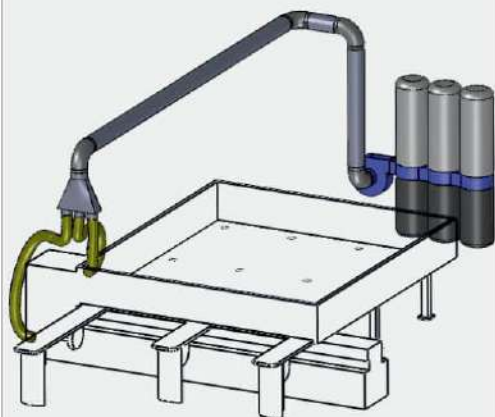

ods. kapacita	4600 m ³ /hod
hrdlo ø	250 mm
výkon	2,2 kW



ods. kapacita	5990 m ³ /hod
hrdlo ø	250 mm
výkon	2,2 kW

Odsávače sú určené na pripojenie drevoobrábacích strojov s požiadavkou na väčší sací výkon.

INTERIÉROVÉ ODSÁVAČE VEĽKÉ

	Nr	€		Nr	€
FT502	180040	2 361,00	FT504	180041	2 639,00

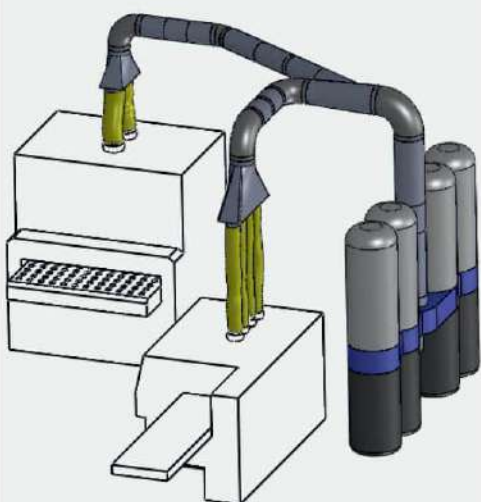

ods. kapacita	7900 m ³ /hod
hrdlo ø	300 mm
výkon	3 kW



ods. kapacita	8700 m ³ /hod
hrdlo ø	300 mm
výkon	3,0 kW

Odsávače sú určené pre vytvorenie menšieho centrálneho interiérového odsávania dielne.

INTERIÉROVÉ ODSÁVAČE MALÉ - ICON 1C



	výkon	ods.kapacita	vrecia	Nr	€
Icon 1C/2	1,5 kW	2 000 m ³ /h	1	712C2010000100	1 232,50
Icon 1C/3	2,2 kW	2 500 m ³ /h	1	712C2010000101	1 271,66

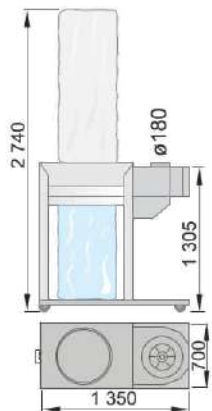

Odsávač je určený k jednému tradičnému stroju s nižšími nárokmi na sací výkon.

INTERIÉROVÉ ODSÁVAČE MALÉ - ICON 2C



	výkon	ods.kapacita	vrecia	Nr	€
Icon 2C/3	2,2 kW	3 000 m ³ /h	2	712C2010000102	1 411,66
Icon 2C/4	3 kW	3 500 m ³ /h	2	712C2010000103	1 652,50

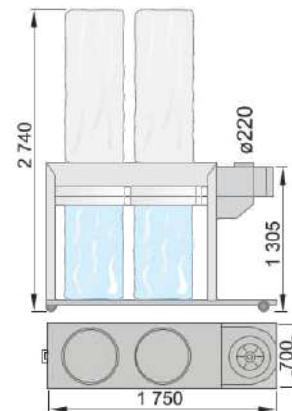

Odsávač je určený k jednému tradičnému stroju s vyššími nárokmi na sací výkon.

INTERIÉROVÉ ODSÁVAČE STREDNÉ - 3C



	výkon	ods.kapacita	vrecia	Nr	€
Icon 3C/4	3 kW	3 500 m ³ /h	3	712C2010000104	1 758,33
Icon 3C/5,5	4 kW	4 500 m ³ /h	3	712C2010000105	1 786,66

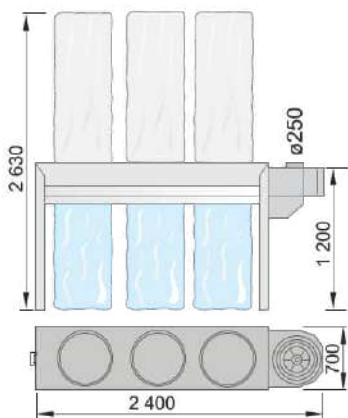

Odsávač je určený k jednému alebo k viacerým obrábacím strojom. Zvlášť vhodný pre olejovačky, nárezová píla a CNC stroje.

INTERIÉROVÉ ODSÁVAČE STREDNÉ - 4C



	výkon	ods.kapacita	vrecia	Nr	€
Icon 4C/5,5	4 kW	5 000 m ³ /h	4	712C2010000106	2 166,66
Icon 4C/7,5	5,5 kW	5 500 m ³ /h	4	712C2010000107	2 565,00

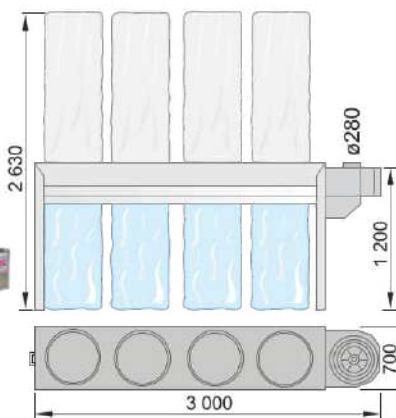

Odsávač je určený k jednému alebo k viacerým obrábacím strojom. Zvlášť vhodný pre olejovačky, nárezová píla a CNC stroje.

INTERIÉROVÉ ODSÁVAČE VEĽKÉ - ICON 5C



	výkon	ods.kapacita	vrecia	Nr	€
Icon 5C/7,5	5,5 kW	6 000 m ³ /h	5	712C2010000108	2 587,50

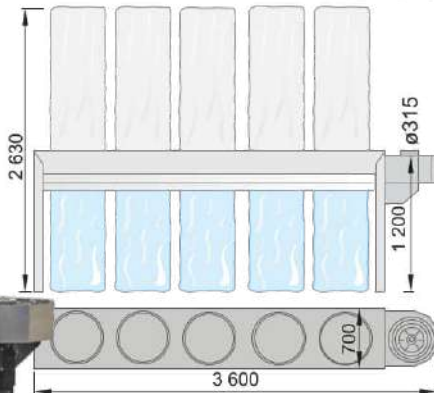
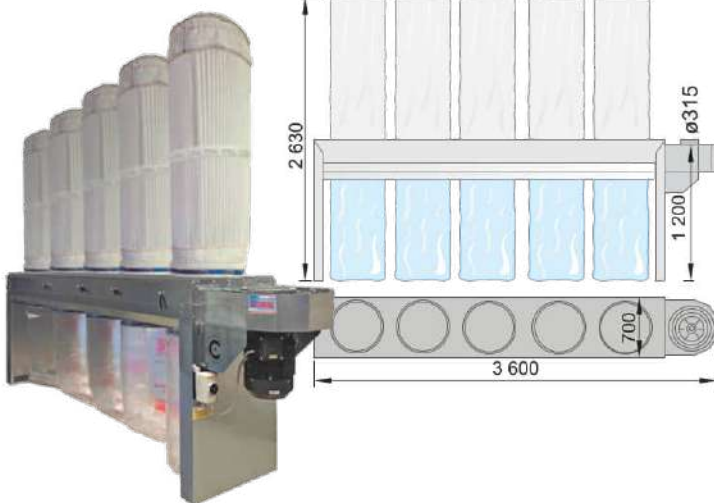

Odsávač je vhodný aj ako centrálné odsávanie do malej stolárskej dielne s možnosťou inštalovania frekvenčného meniča a aut. klapiek v rozvodoch.

INTERIÉROVÉ ODSÁVAČE VEĽKÉ - ICON 5C



	výkon	ods.kapacita	vrecia	Nr	€
Icon 5C/10	7,5 kW	6 500 m ³ /h	5	712C2010000109	3 063,33

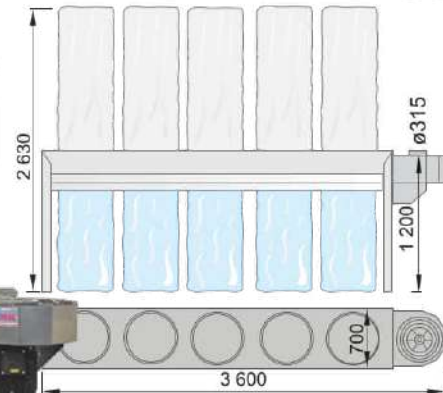
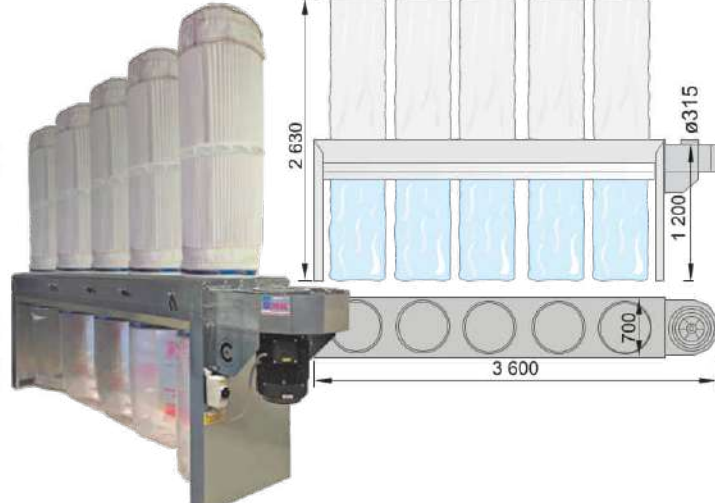

Odsávač je vhodný aj ako centrálné odsávanie do malej stolárskej dielne s možnosťou inštalovania frekvenčného meniča a aut. klapiek v rozvodoch.



CENTRÁLNY ODSÁVAČ ICON PRO 18



	výkon	vrecia	hrdlo ø	Nr	€
IconPro 18/4	3kW	2	220	712C2040000552	4 828,00
IconPro 18/5,5	4kW	2	250	712C2040000553	4 872,00
*IconPro 18/P/4	3kW	2	220	712C204000055202	5 668,00
*IconPro 18/P/5,5	4kW	2	250	712C204000055302	5 712,00

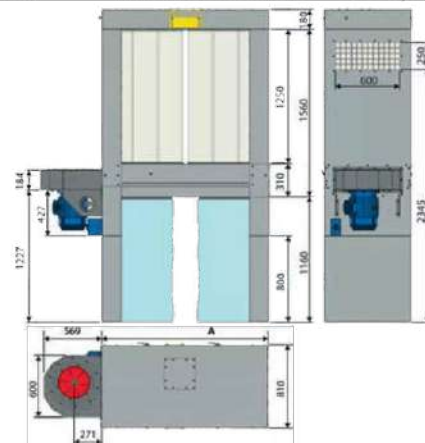

Spofahlivý odsávač do interiéru pre súčasné napojenie viacerých strojov.

*P - panelová verzia

Oživovanie filtračnej batérie vibromotorom.

CENTRÁLNY ODSÁVAČ ICON PRO 27



	výkon	vrecia	hrdlo ø	Nr	€
IconPro 27/7,5	5,5kW	3	280	712C2040000554	6 700,00
IconPro 27/10	7,5kW	3	315	712C2040000555	7 372,00
*IconPro 27/P/7,5	5,5kW	3	280	712C204000055402	7 856,00
*IconPro 27/P/10	7,5kW	3	315	712C204000055502	8 524,00

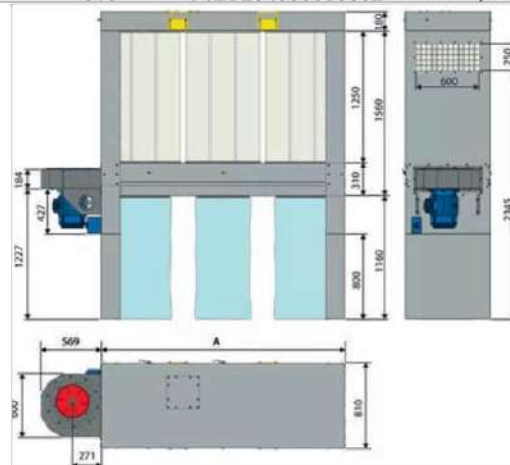

Odsávač do interiéru s možnosťou oplášťovania do exteriéru pre obmedzené centrálné odsávanie dielne. *P - panelová verzia

CENTRÁLNY ODSÁVAČ FM READY

	výkon	vrecia	ods. kapacita	Nr	€
Ready 3RB	5,5kW	45m ²	6 500m ³ /h	712C2040000540	8 305,00
Ready 3NB	7,5kW	60m ²	8 000m ³ /h	712C2040000541	8 973,00
Ready 3HB	11kW	75m ²	9 500m ³ /h	712C2040000542	10 153,00

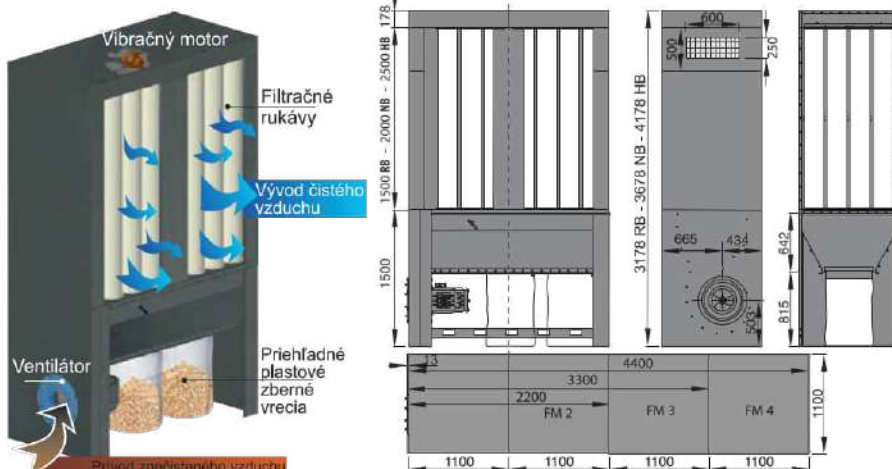

Výkonný odsávač s možnosťou jeho oplášťovania, oživovanie filtrov vibrovaním, integrovaný ventilátor, samonosná konštrukcia. Jedinečný vo svojej triede.





CENTRÁLNY ODSÁVAČ NEGATÍVNY EUROFILTER

	výkon	od.kapacita	fil.plocha	p.filtrov	Nr	€
EuroFilter 160	3kW	1 800m ³	10,8 m ²	24	712C160	7 000,00
EuroFilter 200	4kW	3 000m ³	16,3 m ²	36	712C200	9 887,00
EuroFilter 250	5,5kW	4 500m ³	24,4 m ²	54	712C250	11 637,00
EuroFilter 300	7,5kW	6 000m ³	27 m ²	60	712C300	12 333,00

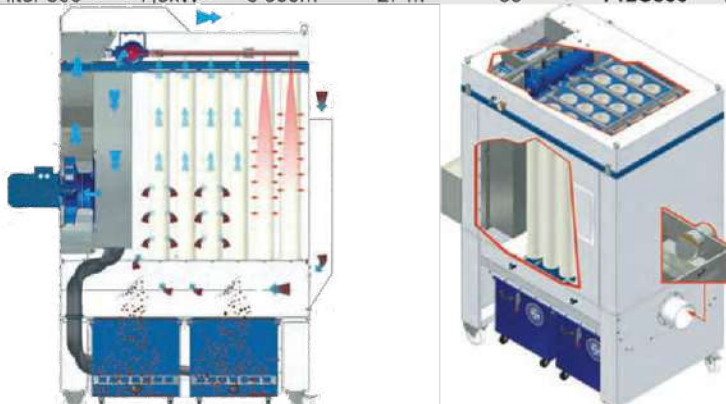

Zariadenie je podtlakové, vybavené antistatickými filtermi, ktoré sú regenerované automatickým motorickým otrepom (za príplatok PULS-JET). Súčasťou dodávky je rozvádzač. Odsávače sú určené pre centrálny odsávací systém v interiéroch. Zámenou dvoch kontajnerov za briketovač je zariadenie pripravené na vynášanie odpadu a jeho komprimáciu do brikiet.



EXTERIÉROVÉ ODSÁVAČE NEGATÍVNY AIRCOM



	ods.kapacita	celkový tlak	fil.plocha	Nr	€
L 1700 2,0	8 960m ³ /h	350 mmH ₂ O	56 m ²	2050000472	na dopyt
L 1700 2,5	11 200m ³ /h	320 mmH ₂ O	70 m ²	2050000349	na dopyt
L 1700 3,0	13 440m ³ /h	360 mmH ₂ O	84 m ²	2050000364	na dopyt
L 2300 2,0	17 920m ³ /h	350 mmH ₂ O	112 m ²	2050000469	na dopyt
L 2300 2,5	22 400m ³ /h	320 mmH ₂ O	140 m ²	2050000350	na dopyt
L 2300 3,0	26 880m ³ /h	360 mmH ₂ O	168 m ²	2050000363	na dopyt

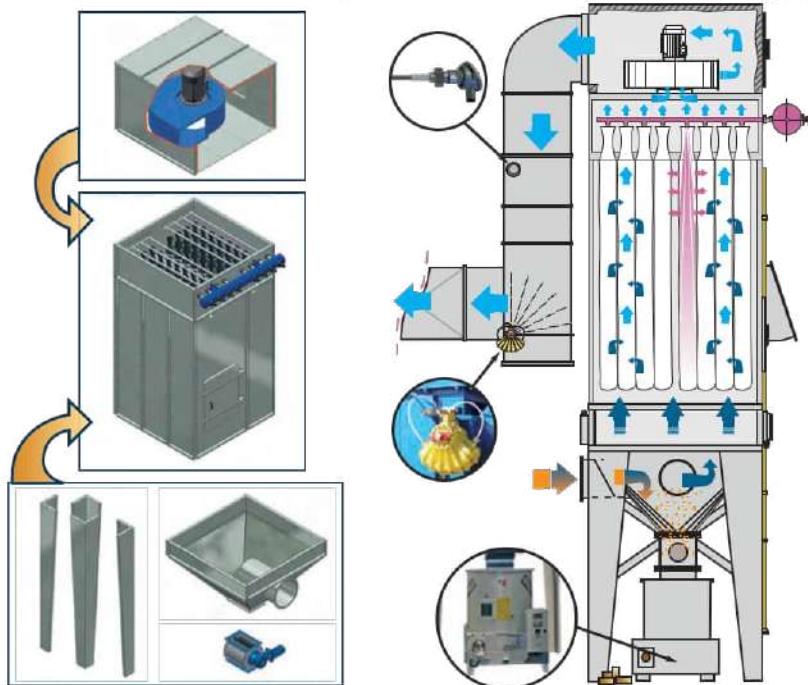

Negatívny exteriérový odsávač s filtrom, oživovaným pulsjetom. Integrovaný ventilátor, zabudované ATEX panely, samozhášací systém, samonosná konštrukcia, vynášanie odpadu priebežné.



EXTERIÉROVÉ ODSÁVAČE AIRCOM



	ods. kapacita	fil.plocha	výkon kW	€
FML 1	6 000m ³ /h	55m ²	5,5	na dopyt
FML 2	9 000m ³ /h	81m ²	7,5	na dopyt
FML 3	12 000m ³ /h	108m ²	11	na dopyt
FML 4	14 000m ³ /h	135m ²	15	na dopyt
FML 5	16 000m ³ /h	162m ²	18,5	na dopyt
FML 6	21 000m ³ /h	181m ²	22	na dopyt

Odsávač pre interiér aj exteriér s priebežným vynášaním odpadu vhodný pre centrálny odsávací systém. Filter oživovaný vibrováním, samostatne stojaci ventilátor.





VENTILÁTOR PODTLAKOVÝ

motor (kW)	výkon max. (m ³ /h)	podtlak (Pa)	hrdlo (ø mm)	€
7,5	10800	3000	450	1 096,-
11	12600	3570	500	1 396,-
15	16200	3870	500	1 693,-

Ventilátor preťahuje cez filter nasávaný vzduch. Cez ventilátor prechádza už vzduch zbavený nečistôt. To umožňuje výrazne vyšší sací výkon (25%) oproti pretlakovému riešeniu.

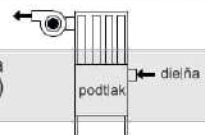

ROTAČNÝ ODDĚLOVAČ TLAKOVÝCH SYSTÉMOV

300x300	€ 1 650,-
---------	-----------

Je súčasťou základnej výbavy odsávača SNEK

Pre vyprázdňovanie SILA počas prevádzky odsávania sa inštaluje rozdeľovač tlaku o menovitom výkone 1,1 kW a prepravnej kapacite 10m³/h.

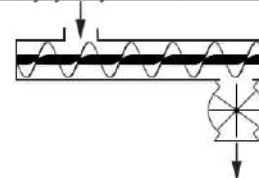

POTRUBIE, TLMIČ, KLAPKA ZIMA-LETO, PROTIPOŽIARNA KLAPKA, DIFÚZOR

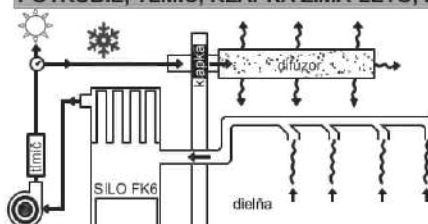

vratný vzduch	€ 1 880,-
---------------	-----------

Vyfiltrovaný vzduch je v režime ZIMA vháňaný potrubím cez protipožiarnu klapku a difúzor späť do výrobného priestoru s minimalizovaním tepelných strát. Manuálnym prepnutím do režimu LETO je vzduch vyústený do ovzdušia.



ROZVÁDZAČ

Cena rozvádzača je individuálna, podľa jeho výbavy.

Elektrorozvádzač je dodávaný s ohľadom na konfiguráciu všetkých zariadení, súvisiacich s odsávacím systémom a požadovanou úrovňou jeho riadenia a monitorovania.

RIADIACI SYSTÉM DRÔTOVÝ

vysielač	€ 80,-
prijímač	€ 27,-

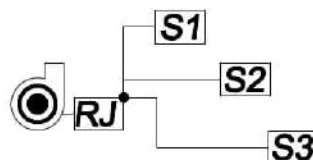

RIADIACI SYSTÉM BEZDROTOVÝ

vysielač	€ 95,-
prijímač	€ 57,-

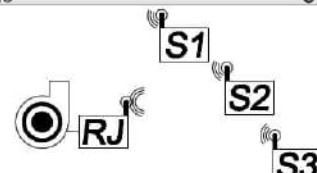

Riadiaci systém zabezpečí aby sa odsávanie bezobslužne spustilo s prvým zapnutým strojom v dielni a vyplo s posledným vypnutým strojom. Odsávanie beží iba vtedy, keď je aspoň jeden stroj v činnosti. Odsávanie je vypnuté, ak nie je žiaden stroj v činnosti. Toto zabezpečí úsporu el. energie.

Na každý stroj je umiestnená jednotka - vysielač, ktorá identifikuje spustenie stroja. Následne bezdrôtovo vyšle signál do prijímacej riadiacej jednotky - prijímača, umiestneného na ventilátore. Prijímač eviduje všetky stroje. Zároveň poskytuje výstupné dáta do PC. Budete mať prehľad o časovej vytáženosti Vášho strojového parku po dňoch, mesiacoch, kvartáloch. Jednoduchá inštalácia a bezproblémové pridávanie jednotiek. Bezúdržbovosť, spoľahlivosť.

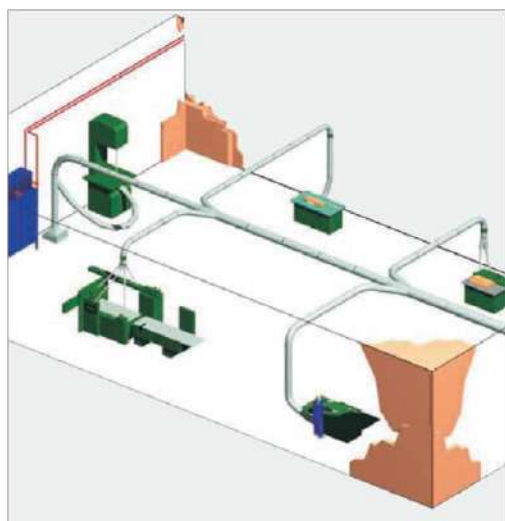

FILTRAČNÁ NADSTAVBA NA BRIKETOVAČ

	€ 6 490,-	€ 5 985,-	
Štvorcová 200		Kruhová 200	
kapacita	13000 m ³ /hod	kapacita	13000 m ³ /hod
hrdlo	400 mm	hrdlo	400 mm
podtlak max.	3600 Pa	podtlak	3600 Pa
motor oklep	0,18 kW	motor oklep	0,18 kW
v x š x h	4900x1870x1870	v x š x h	4900x1870x1870
filtračná plocha	87 m ²	filtračná plocha	87 m ²



Filtračná nadstavba je určená pre pevné spojenie odsávania s briketovačom. Zariadenie je kapotované, vybavené kontrolným priezorom a dverami s automatickým oklepom filtračných vakov. Je určené do malých a stredných prevádzok pre vybudovanie centrálneho odsávania. Spojenie filtra s briketovačom vyhotovujeme na zákazku. Filtračná nadstavba je univerzálna pre pretlakovú, alebo podtlakovú systém. Maximálny pripojiteľný výkon ventilátora (nie je v cene) je 11 kW.



Navrhujeme a vyrobíme Vaše potrubie

PRVKY ROZVODNÉHO POTRUBIA



potrubie hladké

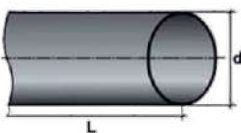

ø d	Nr	€/ bm	ø d	Nr	€/ bm
80	RKH080	13,67	220	RKH220	35,97
100	RKH100	16,74	250	RKH250	38,91
120	RKH120	20,61	280	RKH280	44,43
125	RKH125	20,61	300	RKH300	49,80
140	RKH140	22,91	320	RKH320	49,80
150	RKH150	24,33	350	RKH350	55,95
160	RKH160	25,98	400	RKH400	62,87
180	RKH180	29,06	450	RKH450	70,52
200	RKH200	32,15	500	RKH500	78,27



potrubie spiwo

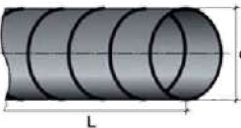

ø d	Nr	€/ bm	ø d	Nr	€/ bm
80	RKS080	4,97	200	RKS200	11,50
100	RKS100	6,10	225	RKS225	13,30
120	RKS120	6,85	250	RKS250	13,90
125	RKS125	7,54	280	RKS280	16,20
140	RKS140	8,45	300	RKS300	17,45
150	RKS150	9,10	315	RKS315	18,79
160	RKS160	9,40	450	RKS450	28,52
180	RKS180	10,43			



koleno 90°

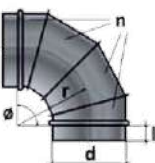

ø d	Nr	€/ 90°	ø d	Nr	€/ 90°
80	FK080R90	13,89	320	FK320R90	39,00
100	FK100R90	14,34	350	FK350R90	48,00
120	FK120R90	17,40	400	FK400R90	57,00
140	FK140R90	19,91	450	FK450R90	63,00
150	FK150R90	20,80	500	FK500R90	77,50
160	FK160R90	21,00	550	FK550R90	93,33
180	FK180R90	21,91	600	FK600R90	120,00
200	FK200R90	22,91	650	FK650R90	144,16
225	FK220R90	25,00	700	FK700R90	155,00
250	FK250R90	26,00	750	FK750R90	165,00
280	FK280R90	29,80	800	FK800R90	219,16
300	FK300R90	34,00			



koleno 30°

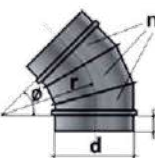

ø d	Nr	€/ ks	ø d	Nr	€/ ks
80	FK080R30	10,20	320	FK320R30	19,00
100	FK100R30	10,60	350	FK350R30	19,91
120	FK120R30	11,00	400	FK400R30	27,91
140	FK140R30	11,50	450	FK450R30	34,16
150	FK150R30	11,72	500	FK500R30	41,41
160	FK160R30	12,00	550	FK550R30	49,16
180	FK180R30	12,40	600	FK600R30	65,83
200	FK200R30	12,91	650	FK650R30	77,00
225	FK220R30	14,00	700	FK700R30	82,50
250	FK250R30	15,00	750	FK750R30	87,50
280	FK280R30	17,08	800	FK800R30	107,50
300	FK300R30	18,66			



redukcia

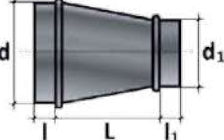

d/d1	Nr	€/ ks	d/d1	Nr	€/ ks
100	RED100	11,00	200	RED200	15,80
120	RED120	12,80	225	RED225	16,00
125	RED125	13,00	250	RED250	16,40
140	RED140	13,80	280	RED280	18,00
150	RED150	14,20	300	RED300	19,80
160	RED160	14,70	315	RED315	21,00
180	RED180	15,20	350	RED350	29,00



redukcia s odbočkou

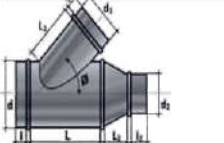

ø d	Nr	€/ ks	ø d	Nr	€/ ks
80	REDOD80	24,00	180	REDOD180	36,20
100	REDOD100	26,20	200	REDOD200	38,90
120	REDOD120	27,90	225	REDOD225	43,20
125	REDOD125	29,30	250	REDOD250	45,40
140	REDOD140	32,30	280	REDOD280	47,30
150	REDOD150	33,40	300	REDOD300	51,90
160	REDOD160	35,20	315	REDOD315	57,80



rozdvojka

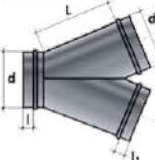

ø d	Nr	€/ ks	ø d	Nr	€/ ks
80	ROZD80	14,20	180	ROZ180	23,90
100	ROZ100	15,90	200	ROZ200	27,60
120	ROZ120	17,40	225	ROZ225	35,20
125	ROZ125	17,90	250	ROZ250	38,60
140	ROZ140	18,80	280	ROZ280	42,60
150	ROZ150	20,80	300	ROZ300	48,80
160	ROZ160	21,10	315	ROZ315	49,90



spona DUO



ø d	Nr	€/ ks
80	711P109080	3,00
100	711P109100	3,20
120	711P109120	3,40
140	711P109140	3,58
150	711P109150	3,75
160	711P109160	3,91
170	711P109170	4,16
180	711P109180	4,58



spona MONO



ø d	Nr	€/ ks	ø d	Nr	€/ ks
200	711P216200	8,70	400	711P216400	10,25
220	711P216220	8,70	450	711P216450	10,25
250	711P216250	8,70	500	711P216500	11,08
280	711P216280	9,25	550	711P216550	12,92
300	711P216300	9,25	560	711P216560	12,92
320	711P216320	9,83	600	711P216600	15,42
350	711P216350	9,83	630	711P216630	15,42
380	711P216380	10,25	720	711P216720	15,42





HRADÍTKA

pneumatické

ø D	Nr	€/ ks
100	711P170100	215,50
120	711P170120	226,00
140	711P170140	218,50
150	711P170150	249,50
160	711P170160	271,00
180	711P170180	232,00
200	711P170200	239,50
220	711P170220	249,60
250	711P170250	271,00
280	711P170280	286,00
300	711P170300	295,00
350	711P170350	405,80

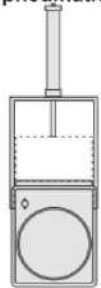

Vyžaduje sa ovládacie napätie 12, 24 alebo 110 V a stlačený vzduch.

mechanické

ø D	Nr	€/ ks
80	711P169080	17,25
100	711P169100	19,17
120	711P169120	19,83
140	711P169140	21,67
150	711P169150	24,17
160	711P169160	25,00
180	711P169180	26,34
200	711P169200	29,92
250	711P169250	34,85
300	711P169300	36,80



HADICE VZ

hadice vulcano ø D	Nr	€/1m
80	607VZ08001	9,10
100	607VZ10001	10,71
120	607VZ12001	13,29
140	607VZ14001	14,14
150	607VZ15001	16,19
160	607VZ16001	18,60
180	607VZ18001	20,72
200	607VZ20001	22,81
250	607VR25401	27,39
300	607VZ30001	32,59

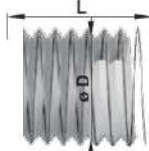

Pre transport 6m stlačené na 1m.

spony na hadice

Nr	€	
80	305.070	0,67
100	305.110	1,08
120	305.120	1,50
140	305.140	1,25
150	305.140	1,25
160	305.160	1,79
180	305.160	1,79
200	305.190	1,88
250	602026	5,70



ODSÁVACIA HUBICA

hubica na odsávanie podlahy 100

Nr 602009 € 70,00

Hubica sa napája na vulcano hadicu ø100 mm.

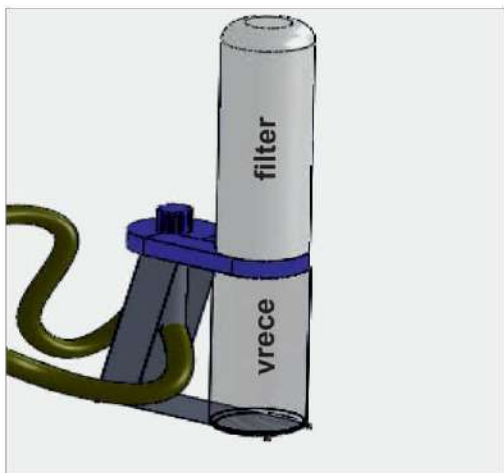

NÁHRADNÉ DIELY

AC WORD

igelitové vrece	Nr	€
700x1400	602021	0,72
1000x1400	602037	0,72

filtračný vak

Nr	€	
FT100 (U1500)	180027F	18,50
FT200 (U2000)	180025F	26,60
FT302 (U3000)	180063	57,40
FT400,500	180024	61,00

CORAL

igelitové vrece	Nr	€
510x1300	712CV5101300Z	1,40

filtračný vak

Nr	€	
500x1250	712C7041120728	58,00



Odolné vrecia pre uskladnenie odpadu.



Atypické rozmery šijeme na mieru.



MONTÁŽNE VZDUCHOTECHNICKÉ POMOCKY

metalická páska	Nr	€
profi	35394664	13,60
hliníková	35346050	6,00

klampiarsky tmel	Nr	€
	334201023RL	3,25

závesné systémy	Nr	€/m
refaz 2,7mm páska Zn.	311.65810208	0,83
	712C134.NAS	1,00



KONZOLOVÝ SYSTÉM

nosník FLS	Nr	€
17/1,0 1m	513F538753	6,67
30/1,0 2m	513F538755	8,29
37/1,2 2m	513F538757	10,0

konzola lištová	Nr	€
17/ 200mm	513F538738	3,83
17/ 300mm	513F538739	3,79
30/ 200mm	513F538740	4,50
30/ 300mm	513F538741	6,71
30/ 450mm	513F538742	8,54
37/ 300mm	513F538743	8,13
37/ 450mm	513F538744	9,17

čap fixačný	Nr	€
FSM Clix M8	513F538651	0,85
FSM Clix M10	513F538652	0,71



príruba sedlová SF Clix 31	Nr	€
	513F538665	7,04

matica posuvná	Nr	€
FSM Clix P8	513F538647	0,54
FSM Clix P10	513F538649	0,54

podložka	Nr	€
HK 31 D8,5	513F538663	0,50
HK 31 D10,5	513F538664	0,50



ODSÁVACIA BRÚSNA STENA



	kW	výkon m ³ /h	L	A x B x C	€
ZINCOCAR DF 1.5	3 kW	6 000	120L	1733 x 1095 x 1653	12 125,-
ZINCOCAR DF 2	4 kW	8 000	152L	2233 x 1095 x 2153	13 670,-
ZINCOCAR DF 2.5	5,5 kW	10 000	187L	3733 x 1095 x 2653	16 000,-
ZINCOCAR DF 3	7,5 kW	12 000	240L	3233 x 1095 x 3153	17 384,-

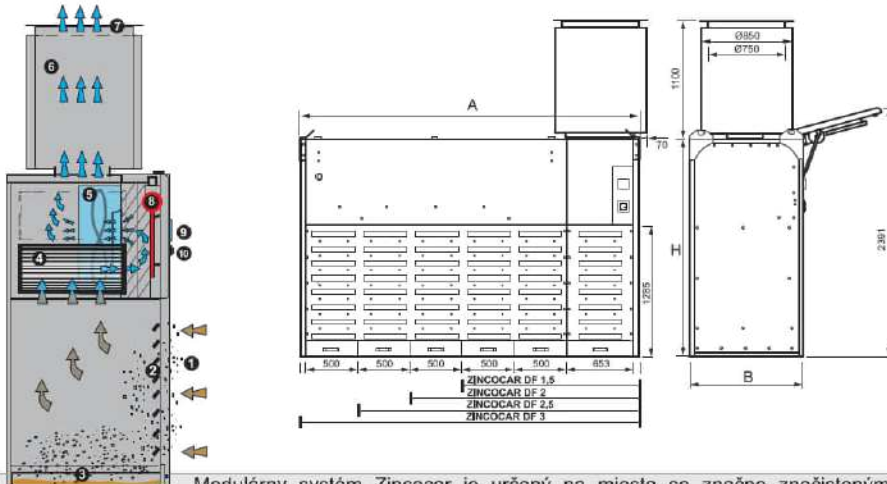

Modulárny systém Zincocar je určený na miesta so značne znečisteným prostredím brúsnym prachom. Podtlakom nasávaný znečistený vzduch z prostredia vchádza do filtračnej časti a prach sa sústreďuje v zberných zásuvkách. Odsávaný vzduch je možné v plnej miere reintegrovať do prostredia aby nedochádzalo k tepelným únikom. Filtračné kartuše sú regenerované (automaticky) cyklicky pomocou stlačeného vzduchu. Vhodné pre pracoviská s intenzívnym brúsením.

BRÚSNE STOLY POLIWOOD

model	L	x	x	Nr	€
Poliwood 1500	1500 mm	4000 m ³ /h	1,6 m ²	712C205404	1 327,00
Poliwood 2000	2000 mm	5000 m ³ /h	2,1 m ²	712C205405	1 592,00
Poliwood 2500	2500 mm	6000 m ³ /h	2,6 m ²	712C205406	2 018,00

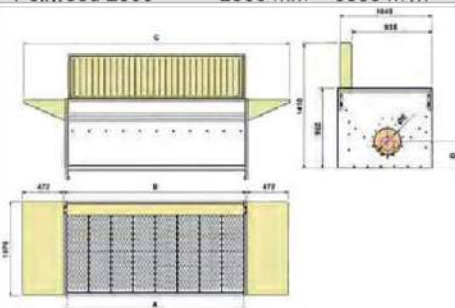

Brúsný stôl z poz. plechu (za príplatok lakovaný) s nastaviteľnou pracovnou výškou je určený na pripojenie k centrálnemu odsávaniu. Tuhá, stabilná konštrukcia umožňuje efektívne brúsenie aj nadrozmerých dielcov.

BRÚSNE STOLY POLIWOOD DF



model	L	motor	výkon	kartuše	Nr	€
DF 1500	1500 mm	3 kW	4000m ³ /h	4 ks	712C205404DF	5 834,00
DF 2000	2000 mm	3 kW	4500m ³ /h	6 ks	712C205405DF	6 910,00
DF 2500	2500 mm	3 kW	5000m ³ /h	8 ks	712C205406DF	8 588,00

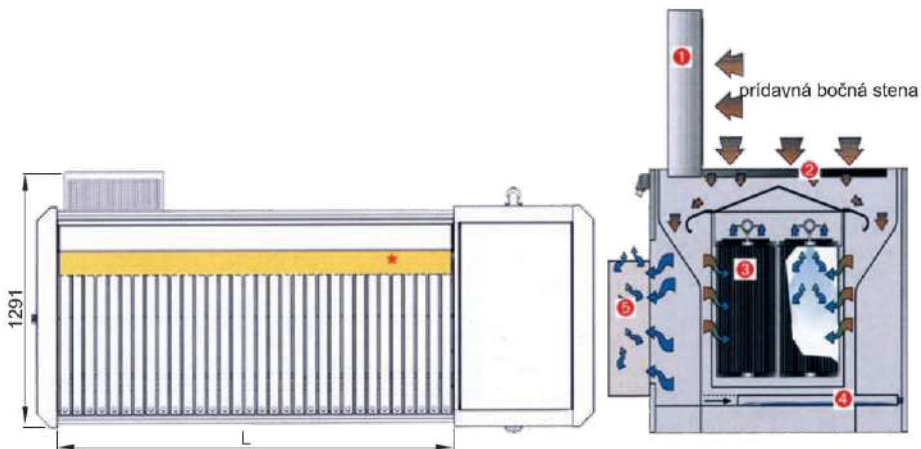

Brúsný stôl má integrované odsávanie a vysoko efektívnu filtráciu. Za príplatok možno doplniť bočnú stenu s osvetlením, hasiace zariadenie a automatickú regeneráciu filtračných kartuší. Negatívny systém odsávania v spojení s „pulsejet“ regeneráciou pozitívne vplyva na životnosť a celkový výkon. Radiálny ventilátor je odhlučnený. Autonómne brúsné pracovisko.



PRIEMYSELNÉ DRTIČE

Grinder Dinamic 600 EVO

€
28 950,-

výkon	max. 300 kg/h.
motor	11 kW
hrdlo ø	150 mm
hmotnosť	950 kg
podávanie	hydraulické

Drtiče pre spracovanie nábytkárskeho a stavebno stolárskeho kusového odpadu o vlhkosti max. 17%. Odhlučnená zberná nádoba. Výmenné sítá pre frakciu 10 mm, alebo 20mm. Spoľahlivé robustné riešenie, bezúdržbová prevádzka. Vymeniteľné, lacné nože.

BRIKETOVAČE

Press Dinamic 70S 16 900,-
Kg/H 30+75Press Dinamic 110S 23 850,-
Kg/H 50+110Press Dinamic 200S 34 950,-
Kg/H 70+220

výkon	max. 60 kg/h.
motor	5,5 kW
brikety ø	65 mm
hmotnosť	830 kg
nádoba ø	1 100 mm

výkon	max. 110 kg/h.
motor	7,5 kW
brikety ø	65 mm
hmotnosť	960 kg
nádoba ø	1 000 mm

výkon	max. 250 kg/h.
motor	11 kW
brikety ø	75 mm
hmotnosť	1600 kg
nádoba ø	1 200 mm

Hydraulické briketovače pre bezobslužnú výrobu brikiet zo sypkej drevnej hmoty s max. vlhkosťou 17%. Ponúkame bohaté príslušenstvo - filtračné nadstavby, baličky, egalizačné mlyny. Spoľahlivá, masívna konštrukcia zabezpečuje mimoriadne ekonomickú prevádzku.

PRÍSLUŠENSTVO

balička brikiet 3450,-

homogenizátor 5300,-

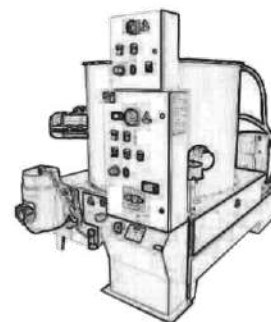

Stabilná konštrukcia baličky zabezpečuje motorické otáčanie turniketu, na ktorom je upevnených 10 PVC vriec. Po naplnení jedného vreca sa turniket otočí o jednu pozíciu. Možnosť aplikovať ku každému briketovaču. Nezávislé ovládanie baličky.

Homogenizátor zabezpečuje homogénnu frakciu materiálu, z ktorého je vyrábaná briketa. Je internou súčasťou briketovača (doporučuje sa pre model 250). Vyžaduje sa pri centrálnych odsávacích systémoch, kde všetok odpad je smerovaný do briketovača.



POVRCHOVÁ ÚPRAVA STRIEKANÍM



STRIEKACIA STENA

	L	P	Q	€
TECHNODRY 2	2m	1,5kW	7 000 m ³ /h	3 065,-
TECHNODRY 2,5	2,5m	1,5kW	10 000 m ³ /h	3 720,-
TECHNODRY 3	3m	2,2kW	10 000 m ³ /h	3 980,-

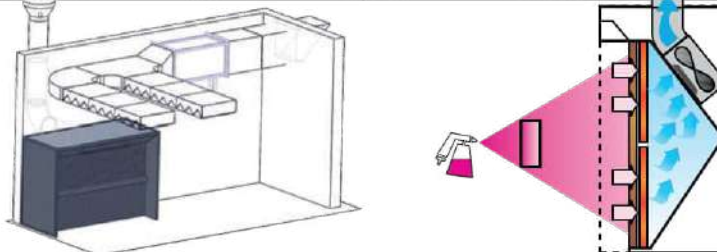

Stena z pozinkovaného plechu so zabudovaným ventilátorom je vybavená účinnou 2-stupňovou filtráciou. Špeciálny systém sania zabezpečuje rovnomerné prúdenie vzduchu na celej ploche steny. Výkon sania je regulovateľný. Vstavané osvetlenie je súčasťou základnej výbavy.

TERMOVENTILAČNÁ JEDNOTKA

	Q	€
CTA 1	6000 m ³ /h	4 761,-
CTA 2	10000 m ³ /h	5 494,-
CTA 3	16000 m ³ /h	7 539,-

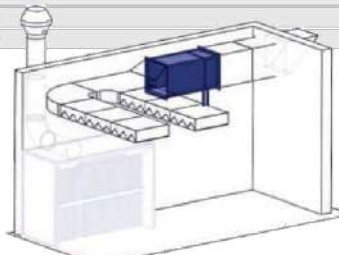

ventilátor
výmeník
filter
žalúzia



V jednotke je integrovaný ventilátor, výmenník tepla, filter a regulátor prísavania. Predpokladá sa pripojenie na TUV z vykurovacieho systému. Kompaktné, nízkoohľudné zariadenie je možné inštalovať aj mimo striekárne. Jednotka je systémom vzduchotechnického rozvodu napojená na distribútor vratného vzduchu, do ktorého vŕhajú vzduch z exteriéru kondicionovaný na požadovanú teplotu, zariadený nečistôt v požadovanom objeme, odpovedajúcom výkonu odsávania. Riešenie predpokladá DT 20.

DISTRIBÚTOR VRATNÉHO VZDUCHU

	€
pre TECHNODRY 2	1 600,-
pre TECHNODRY 2,5 / 3	1 900,-
pre ECOFIT 15	2 400,-
pre ECOFIT 30	2 900,-

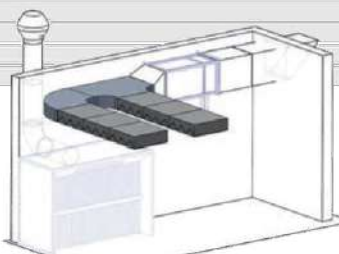

Vratný vzduch je do priestoru striekárne vŕhajú cez stropné filtračné panely v množstve, aby priestor bol tlakovo neutrálny. Rovnomerná, tichá a dokonale filtrovaná distribúcia vzduchu zabezpečuje jeho optimálne prúdenie s dopadom na úplnú sterilnosť prostredia. Veľkosť distribučnej plochy je závislá na technickom riešení striekárne.

STRIEKACIA KABÍNA



	Q	€
ECOFIT 15	15 000m ³ /h	14 500,-
ECOFIT 30	30 000m ³ /h	16 000,-

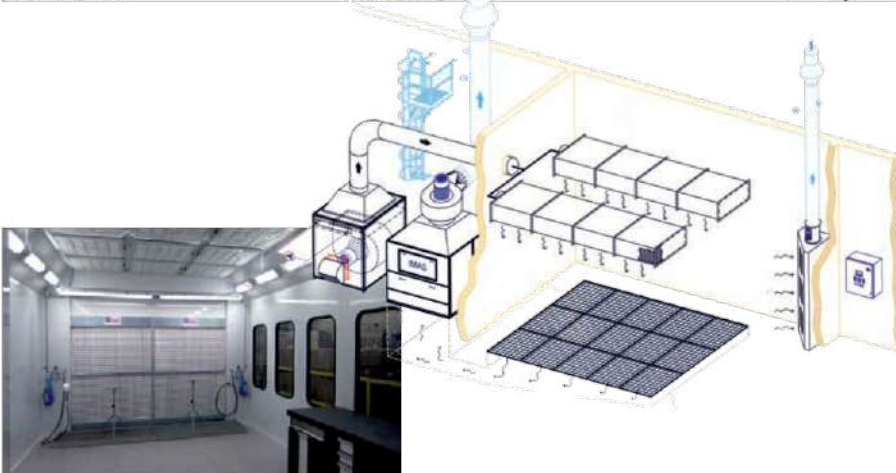

Odsávanie, vedené systémom kanálov v podlahe predpokladá stavebnú pripravenosť. Oceľový rošt, je umiestnený v samonosnej konštrukcii a je aktívnou pracovnou zónou. Odsávací jednotka môže byť umiestnená mimo striekárne. Je vybavená kartušovými filtermi s oklepom. Vzduch je vyústený do ovzdušia s regulovateľnou rýchlosťou prúdenia. Takéto usporiadanie striekárne reprezentuje vysoký priemyselný štandard.



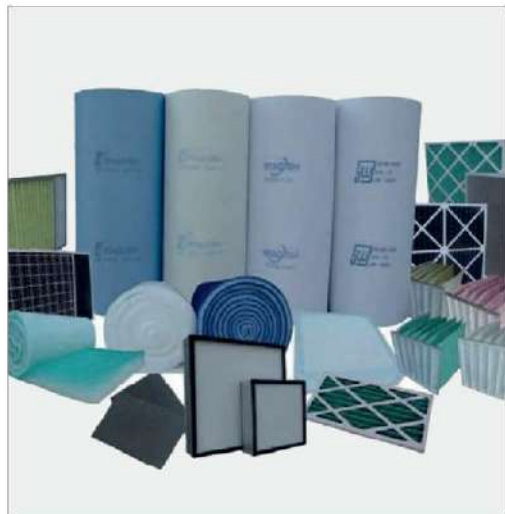

OBSAH

FILTRAČNÝ PAPIER

B	L	Nr	€
TEC 2	900mm	10m	712C7041000009 100,-

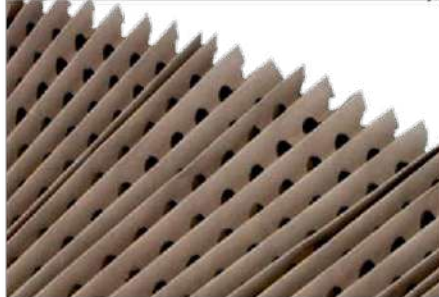

Filtračný papier je navrhnutý na základe ISO 14000, s hustotou papiera až 250g/m².

FILTRAČNÁ TEXTÍLIA

Nr	€
500x860x48	712C041010029 60,00

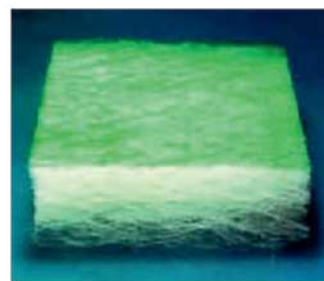

Náviny a výrezy špeciálnych filtračných sklenných textílií v hrúbkach 25 až 95 mm s extrémne vysokou pohltiteľnosťou prachu a prietočnosťou. Progressívna hlbková filtračná štruktúra.



OCHRANNÉ OBLEKY

Nr	€
355P116013110095	2,-



Jednorázový oblek z netkanej textílie a predĺženou životnosťou

RESPIRÁTORY

Nr	€
maska 353L6300	20,-
353M6200	20,-



pre silne záťažové prostredie

respir. 355P7232 1,33 s ventilom

MULTISTÔL

rozteč ramien	Nr	€
ø 25 ~ 1100 mm	460CKRS	323,00

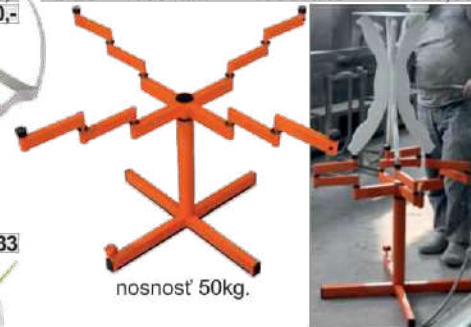

nosnosť 50kg.

Nastaviteľné ramená umožňujú ľubovoľnú konfiguráciu, potrebnú pre striekanie dielcov alebo konštrukcii rôznych rozmerov.



STOJAN KRAF E

L	h	Nr	€
550mm	106mm	360A55010	259,00



Konštrukcia umožňuje modulárne rozširovanie stojanov v šírkach 370 alebo 660 mm. Maximálna hmotnosť jedného dielca 10 kg.



STOJAN KRAF W

L	h	Nr	€
550mm	106mm	360A55020	599,00



Nožnicová konštrukcia stojana umožňuje rozširovanie stojana v rozsahu 300 až 1200 mm. Otočné ramená ponúkajú možnosť obojstranného zakladania dielcov s maximálnou hmotnosťou 20 kg.



PRÍSLUŠENSTVO



OPRavnÝ VOSK MÄKký - KO140 

jednotná cena pre všetky odtiene	Nr 608140xxx	€ 2,49
----------------------------------	-----------------	-----------



na sklade držíme 150 odtieňov

Na opravu rýh, dier, škrabancov a prehĺbenín. Pre povrchy-drevo, dýha, lamino, fólia, umelá hmota. Použitie na málo namáhané časti povrchu (opravy v ploche).

OPRavnÝ VOSK TVRDÝ - KO141 

jednotná cena pre všetky odtiene	Nr 608141xxx	€ 2,49
----------------------------------	-----------------	-----------



na sklade držíme 150 odtieňov

Na opravu rýh, dier, škrabancov a prehĺbenín. Pre povrchy-drevo, dýha, lamino, fólia, umelá hmota. Použitie na silne namáhané časti. (rohy, hrany, pracovné dosky, podlahy atď.)

ŠPACHTLOVÝ SET 

špachtľový set	Nr 608161500	€ 13,75
----------------	-----------------	------------



Patentovaná plastová špachtľa na aplikáciu opravných voskových tmelov.

ELEKTRICKÁ PIŠTOĽ

elektrická pištoľ	Nr 608440505	€ 106,-
el. zdroj	608440505	106,-
náhradný hrot	608440503	33,-
náhradný hrot	608440502	61,-



Elektrická pištoľ s plynulou reguláciou k taveniu a miešaniu všetkých voskových tmelov. (vhodný do výroby)

BATERKOVÁ PIŠTOĽ

baterková pištoľ	Nr 60800101	€ 39,75
------------------	----------------	------------



Baterková pištoľ s reguláciou pre aplikáciu tvrdých tmelov-voskov. Obzvlášť vhodná pre montáže.

OPRavnÝ LAK - KLARLACK 

balenie 400 ml	Nr	€
mat KO337	608337000	23,29
pololesk KO330	608338000	17,67
vysoký lesk KO340	608400000	15,58



Vrchný opravný lak - transparentný. Používa sa tak ako k novým, tak i k opravným nástrekom. Zabraňuje vytvoreniu tzv. efektu „pomarančovej kôry“. Vhodný pre drevo, plast a kov.

SERVISNÝ KUFOR 

servisný kufor nábytkársky	Nr 608611000	€ 362,50
----------------------------	-----------------	-------------



do každej nábytkárskej výroby

OPRavnÉ FIXKY 

opravné fixky (13 odtieňov)	Nr 323.10xx	€ 13,08
-----------------------------	----------------	------------



k dispozícii 12 odtieňov

01 Dub svetlý	02 Dub stredný	04 Orech stredný	06 Orech tmavý
07 Mahagón.hned	08 Mahagón.cervec	12 Čierny	13 Biely
14 Čerešňa	15 Buk	16 Červený smrek	17 Jelša

Retušovacie fixky pre opravu spôsobenú škrabancami na malých plochách. Použitie je veľmi jednoduché. Fixky sú plnené priesvitným farebným lakom v 11 odtieňoch a vo farbe bielej a čiernej.

OPRAVNÝ TMEL

CLOU

obsah
tuba 250g

Nr
323.9xx

€
3,67



k dispozícii 15 odtieňov



Vodou riediteľný tmel na drevo CLOU sa používa na tmelenie priehlbín, trhlín a medzier. Rýchlo schne, dobre vyplňuje tmelené miesto bez prasklín, neprepadáva sa. Tmelený povrch je možné brúsiť, frézovať, píliť, vŕtať a tiež moriť. Dodáva sa v 13-tich odtieňoch dreva a v bielej a čiernej farbe.

TAVNÝ TMEL

THERMELT

AKRYLÁTOVÝ TMEL

PAM

Nr €
tyčinka 352004 2,95

orezávač Nr €
30 mm 352011 26,67
50 mm 352012 30,00

Nr €
chladič 352013 7,50

objem Nr €
0,6kg 343340080 3,67



Výplne tavným tmelom sú najlepším riešením pre opravy drevených povrchov, ako je vyspravovanie prasklín, hlbokých poškodení, vypadaných hrčí, a aj iných menších či väčších defektov dreva.

Na aplikovanie použijete bežnú tavnú pištoľ. Priložte na opravené miesto chladič, za pár sekúnd môžete orezávačom opravené miesto vyhladiť.



Jednozložkový tmel na vodnej báze, určený na tmelenie prasklín a spojov. Povrch je brúsiteľný, lakovateľný. Bráni prenikaniu vody.

Vyrába sa vo farebných odtieňoch: biely, dub, buk, smrek, natural, borovica, parený buk, jelša, gaštan, čerešňa.

EPOXY UNIVERSAL

BISON

EPOXY METAL

EPOXY AQUA

BISON

obsah
tuba 56g

Nr
33590042

€
4,71

objem
24 ml

Nr €
33590010 9,04

objem
56 g

Nr €
33590072 4,96

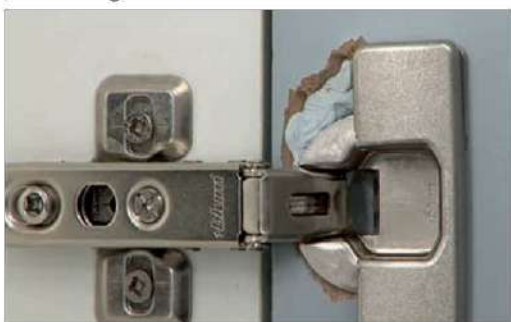

Rýchlo vytvrdzujúce dvojzložkové epoxidové lepidlo bez prchavých rozpúšťadiel na permanentné opravy, lepenie a fixovanie. Vďaka statickému zmiešavaču je zmiešanie oboch zložiek precízne a aplikácia veľmi jednoduchá a rýchla. Lepí, opravuje a fixuje takmer všetky materiály.



Vhodné pre lepenie kovov, plastov, skla, mramoru, gumy, PVC, aglomerátov.



Dvojzložkový epoxidový tmel určený do vlhkého prostredia (kuchyňa, kúpeľňa).



SPREJOVÉ LEPIDLO

Pattex

EPOXY REPAIR

Pattex

objem
400 ml

Nr
507272776

€
9,29

objem
48g

Nr
507117789

€
4,58



OPRAVUJE TESNÍ LEPI



Lepidlo na dekoratívne práce a lepenie pri montáži. Stačí len jednoducho nastriekať, chvíľu počkať a spoj drevo, papier, koža, plast... je hotový.

Epoxidová opravná hmota pre expresné lepenie kuchynského a kúpeľňového príslušenstva. Vhodné pre utesňovanie škár v potrubí. Po vytvrdnutí je miesto spoja brúsiteľné, pretierateľné.

TEFLON HP PTFE 

objem	Nr	€
400 ml	33520025	7,88



Poskytuje lubrikáciu, redukuje trenie a opotrebenie. Predlžuje životnosť zariadení.

SILIKON 

objem	Nr	€
400 ml	33520027	7,00



Mazivo s vysokým klzavým účinkom, chráni proti vlhkosti. Nepriťahuje nečistoty.

LITHIUM WHITE 

objem	Nr	€
400 ml	33520028	8,21



Mazivo - biela vazelína ktorá pri aplikácii nekvapká ani netečie. Znižuje trenie. Chráni pred koróziou.

HRDZA 

objem	Nr	€
400 ml	33520026	6,65



Uvoľňuje zadreté a zhrdzavené skrutky a spoje. Peniká do ťažko prístupných miest.

UNIVERZAL 

objem	Nr	€
100 ml sprej	33520002	2,25
250 ml sprej	33520040	3,58
250 ml sprej - slamka	33520029	2,92
450 ml sprej - slamka	33520014	6,58



Univerzálne mazivo je okamžite a maximálne účinné, rýchlo penetrujúce mazivo a konzervant. Zlučuje vlastnosti niekoľkých výrobkov. Nenahraditeľný pomocník domácich majstrov a profesionálov

CLEVER STRAW 

objem	Nr	€
500ml	33533026	4,96



Zanecháva tenký film, ktorý chráni kovový povrch pred koróziou. Peniká hrdzou. Vytlačá vlhkosť, čistí, maže závesy, zastavuje výzvanie, redukuje trenie, uvoľňuje skrutkové spoje.

ODMAŠŤOVAČ SÚČIASTOK 

obsah	Nr	€
1000g	613001	7,50



Profesionálny odmašťovací prostriedok. Riedený aj neriedený vodou pre univerzálne použitie. Čistí aj chromované a hliníkové povrchy, nezanecháva šmuhy, flaky a dá sa použiť aj ako odhrdzovač.

TEFLONOVÝ SPREJ  Den Braven

objem	Nr	€
400 ml	334TA21101	5,42



Premazávanie tepelne namáhaných dielov, klzkých i trecích plôch a pod. Zabezpečí dlhodobé a kvalitné premazanie vedení. Odpudzuje nečistoty, prach, vlhkosť, vodu, je antiadhezívny.

SPREJ NA REMENE  LOCTITE 8005

obsah	Nr	€
400g	6038022	14,70



Sprej na prínavosť remeňov zabraňuje ich prešmykovaniu a predlžuje životnosť.

SILIKÓNOVÝ SPREJ  LOCTITE 8021

obsah	Nr	€
400g	507232368	9,58



Silikónový olej - spray, vhodný na bežnú údržbu klzkých plôch strojov.

TEKUTÝ ZINOK ZINC

objem 400ml	Nr 613008	€ 10,63
----------------	--------------	------------



ZINC je ochranný prostriedok na kovové povrchy, obsahujúci mikronizovaný kovový zinkový prášok disperzovaný do špeciálnej živice. Určený pre retušovanie na elektroliticky galvanizovaných povrchoch a predmetoch.

TEKUTÁ NEREZ STEEL

objem 400ml	Nr 613009	€ 12,08
----------------	--------------	------------



Vyriešite ťažkosti s opravami nerezových plôch. STEEL je skvelý prípravok na dodatočnú povrchovú úpravu plôch namáhaných vlhkosťou, chemickými prostriedkami. Vhodné pre montážnikov kuchýň.

ODSTRAŇOVAČ NALEPENÝCH NEČISTÔT NEUTRINE

obsah 400g	Nr 613003	€ 6,20
---------------	--------------	-----------



Vysokoučinné a bezpečné odmasťovanie vnútorných stien kuchynských rúr.

ČISTIČ POTRUBIA MELT

obsah 400g	Nr 613006	€ 9,33
---------------	--------------	-----------



Rýchlo účinkujúci prostriedok na prevenciu a opravu upchatých odpadov. Nalejte MELT do výlevky, nechajte chvíľu pôsobiť. Prečistené potrubie bude ako nové. Vhodné pre montážnikov kuchýň.

TOPUP Klein

obsah 400ml	Nr 606005	€ 16,25
----------------	--------------	------------



Prípravok tvorí odolný, vodu odpudzujúci suchý film, ktorý dramaticky znižuje klzné trenie na stoloch píly a povrchoch nástrojov. Výrazne znižuje klzné trenie, odpudzuje prach, nečistoty, vlhkosť a zabraňuje korózii.

LUBRIKANT TRIVALENTE

objem 5 litrov	Nr 280K001M01	€ 68,80
-------------------	------------------	------------



Trivalente značne znižuje trenie medzi kovom a drevom. Použitý ako mazadlo stolov, aj ako prevenciu proti hrdze. Vhodné pre spodné a štvorstranné frézy, zrovnávačky, hrúbkovačky.

ČISTIČ NÁSTROJOV PULITOOL

objem 5 litrov	Nr 280K00JM02	€ 55,80
-------------------	------------------	------------



Pulitool bez námahy, dokonale vyčistí Vaše frézy, píly, vrtáky. Po namočení nástroja do zriedeného roztoku sa nalepené živice, spálený povrch a iné usadeniny úplne odstraňuje.

CLEANUP Klein

objem 1L	Nr 606003	€ 17,50
-------------	--------------	------------



Prípravok je vhodný na čistenie drevoobrábacích nástrojov. Odporúča sa použitie koncentrácie 5 až 35 percent s teplou vodou pre namáčanie nástrojov.



STUŽIDLO

L max	Nr	€
150	302001	15,40
200	302002	15,83
250	302003	16,30
300	302004	17,00
350	302005	17,58
400	302006	18,92
500	302007	20,92
700	302008	22,42
800	302009	25,00

L max	Nr	€
1000	302010	26,50
1250	302011	28,25
1500	302012	31,08
1750	302013	33,25
2000	302014	35,50
2200	302015	37,50



prídavná zvierka - jednoduchá
302000 12,55

prídavná zvierka - dvojité
70 mm 3020001 16,60
140 mm 3020002 17,50



GRIP

L	Nr	€
150	612T506QCEL7	21,10
300	612T512QCEL7	42,50
450	612T518QCEL7	28,70
600	612T524QCEL7	30,80



Jednoručná "račňová" patentovaná zvierka zabezpečuje trvalú upínaciu silu 136 kg s minimálnou fyzickou námahou.

GRIP XP

L	Nr	€
150	61210505942	20,42
300	61210505943	24,58
450	61210505944	27,58
600	61210505945	30,33
900	61210505946	34,63
1250	61210505947	38,25



Jednoručná "račňová" patentovaná zvierka zabezpečuje extrémnu upínaciu silu 272 kg s minimálnou fyzickou námahou.

SŤAHOVÁK ČAPOV

L max	Nr	€
3000	302041	116,00
2000	302042	99,00
1500	302043	90,00



Konštrukcia sťahovák vychádza z osvedčených liatinových prvkov za použitia trapézových skrutiek. Jednotlivé prvky sú dodávané aj ako náhradné diely.

SŤAHOVÁK NA ŠKÁROVKU

L	Nr	€
800	302022	65,00
1200	302020	71,40
1300	302021	75,00



Sťahovák sa používajú pri výrobe škároviek. Ich prednosťou, vyplývajúcou z konštrukcie je schopnosť vyvinúť prítláčny tlak zo všetkých štyroch strán, čo zabraňuje prehybaniu sa resp. vydúvaniu sa zlepovaných výšov.

KLEMMSIA

L	Nr	€
300	322.0030	12,33
600	322.0060	15,75
1000	322.0100	21,50

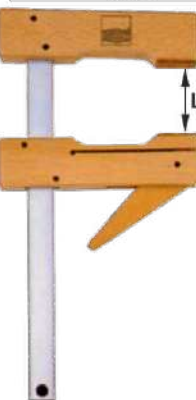

Používa sa pre tuhé, ale veľmi šetrné fixovanie obrobkov v prednastavenej pozícii. Nenahraditeľné upínaky pre viac remesiel.

RAČŇOVÁ UPÍNKA

balenie	Rozmer	Nr	€
1ks	160x60 mm	360A16060	26,58
1SET (2ks)	160x60 mm	360A16060S	49,50



Pre upnutie lišty Festool, Makita.



Vhodné pre dierovaný stôl Festool.

BAKY

	Nr	€
A sada križov (2 ks)	302018	17,00
B uťahovací kľúč	302019	12,00

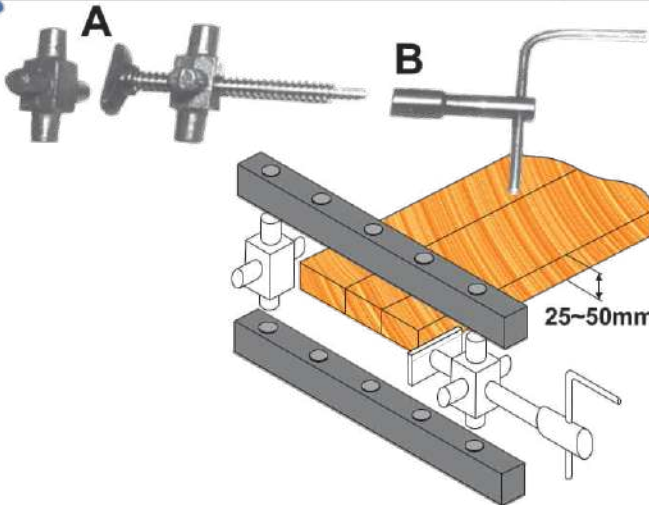

Používa sa na škárovanie v kombinácii s drevenými lištami (nie je predmetom dodávky). Rozsah hrúbok lepenej škárovky je podľa natočenia križa od 25 do 50 mm.

PRUŽINOVÉ SVORKY

	upínanie	Nr	€
Wolfcraft FZ 60	60 mm	4483631	2,25
IRWIN T581	25 mm	612T58300EL7	7,79
IRWIN T583	75 mm	612T58100EL7	3,78



Zvierka s pohyblivými čelustami.

MT 70	70 mm	4483633	2,79
-------	-------	---------	------



Zvierka pre optimálne upnutie v úzkych medzerách.

JEDNORUČNÁ ZVIERKA EHZ PRO

EHZ PRO	upínanie	Nr	€
	300 mm	4483030	22,08
	450 mm	4483031	19,58
	700 mm	4483032	20,67
	915 mm	4483033	22,92



Rýchle a bezpečné upnutie jednou rukou, upínacou silou až do 120kg.

CONNECTOR PRO	Nr	€
	4483038	11,96



Pre spojenie dvoch jednoruč. svoriek.

RAČŇOVÁ SVORKA - HANDY

	upínanie	Nr	€
HANDI 50	50 mm	612T59200ECD	6,63
HANDI 100	100 mm	612T59400ECD	7,46



Bodová zvierka so silným upnutím.

MOBILNÝ UPÍNAČ

upínanie	Nr	€
65 mm	4483415	22,33



Tretia ruka pre remeselníka, upínací prípravok na pravouhlé spojenie

SKRUTKOVÉ ZVIERKY SZ

SZ	upínanie	vyloženie	Nr	€
	300 mm	80 mm	4483611	21,90
	450 mm	120 mm	4483612	23,25
	300 mm	120 mm	4483613	26,95
	450 mm	120 mm	4483614	31,95
	700 mm	120 mm	4483615	36,90
	1000 mm	120 mm	4483623	40,10



Stolárska zvierka tuhej a ergonomickej konštrukcie, ktorá nepovolí.

CONNECTOR PRO	Nr	€
	4483037	12,80



Nástavec na lepenie náglejkov.

KORPUSOVÁ ZVIERKA

L	Nr	€
1000 mm	322.KRE100-2K	82,50
1500 mm	322.KRE150-2K	109,20
2000 mm	322.KRE200-2K	157,50
2500 mm	322.KRE250-2K	170,40

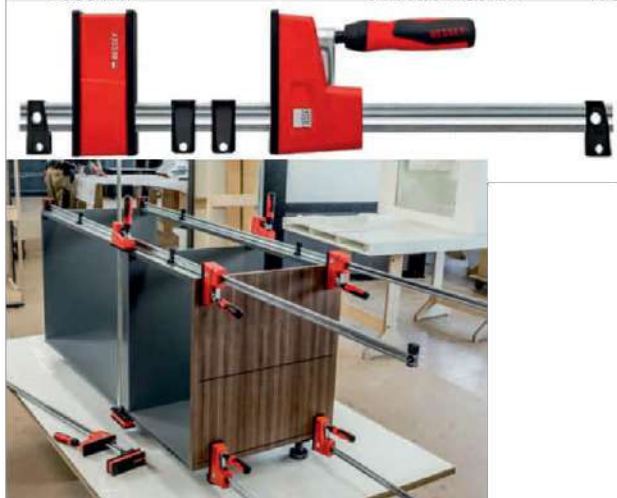

Nábytkárska zvierka pre korpusy je použiteľná pre vytvorenie stabilného montážneho pracoviska. Sila až 800 kg.

variabilný horný diel	
Nr	322.KRE-VO
€	23,80

sada držiakov	
Nr	322.KP
€	30,80

naklápači adaptér (2ks)	
Nr	322.KR-AS
€	14,40

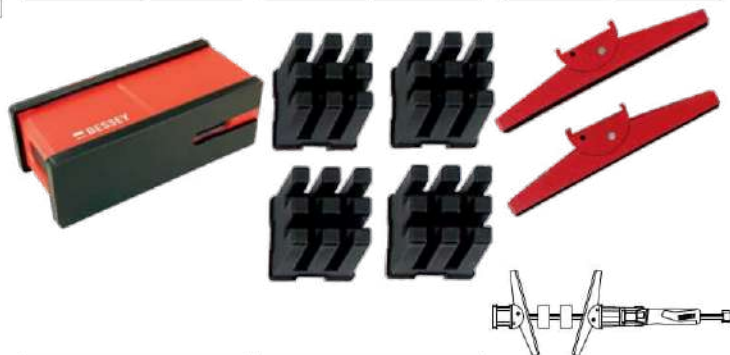

Príslušenstvo korpusovej zvierky rozširuje jej použitie pri montáži a umožňuje variabilné využitie

KORPUSOVÝ UPÍNAČ KS

	Nr	€
200-1000	322.KS100	140,50
200-1500	322.KS150	142,40
predĺženie 1000	322.KSV	66,40



Skvelý pomocník pri montáži korpusov nepravidelných tvarov.

NAPÍNAČ PÁSKY BAN

	Nr	€
BAN400 rozsah do 4m	322.00061	28,58
BAN700 rozsah do 7m	322.00062	36,46



Profesionálne riešenie výroby tvarových dielcov so zabezpečeným rovnomerným a trvalým tlakom.

HRANOVÁ ZVIERKA EKT

EKT	L	Nr	€
	10-55mm	322.EKT55	62,80



Pre lepenie náglejok tvarových dielcov.

UPÍNAČ DOSIEK

	Nr	€
PS130	322.PS130	729,-
PS55	322.PS55	278,-



Pre spájanie veľk plošných dielcov, kde sa vyžaduje ich rovinnosť.

ZVIERKA NA HRANY

B	Nr	€
10 - 60	302080	50,00
náhradná guma	302085	5,50

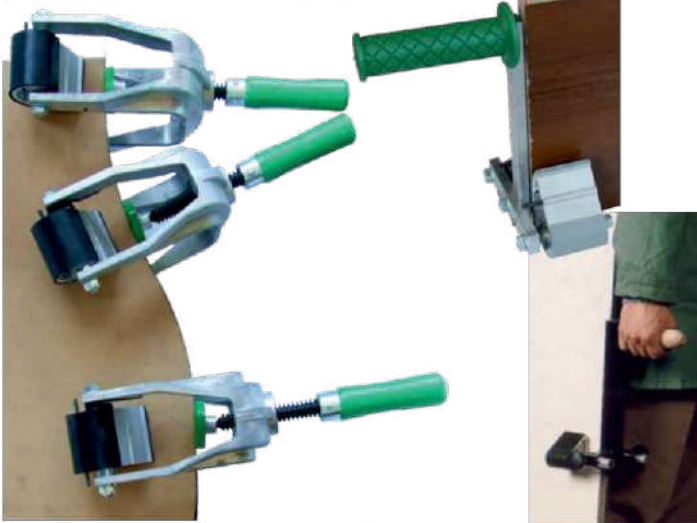

Zvierka sa používa pri nalepovaní náglejkov na tvarové hrany.

MANIPULAČNÁ ZVIERKA

B	Nr	€
10~50	302088N	82,50



Zvierka uľahčuje manipuláciu s veľkoplošným materiálom.

LIFTER

nosnosť	Nr	€
100kg	606100	62,80



Lifter uľahčuje osadzovanie dverí do zárubní.

ZVIERKA NA ZÁRUBNE

	Nr	€
1. výstuha zárubne TU	322.00053	73,25
2. vyrovnávací zvierka TFM	322.00055	37,04
3. uhlová zvierka WTR	322.00056	77,42
4. jednoduchá výstuha TMS	322.00057	32,63

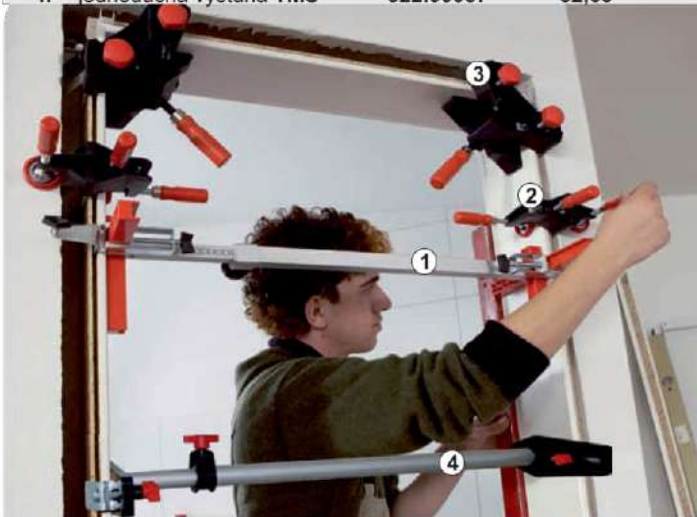

Premyslený systém pre montáž dverových zárubní.

OBLÚKOVÝ ŠTAHOVÁK

	Nr	€
manuálna zvierka	302081	81,50

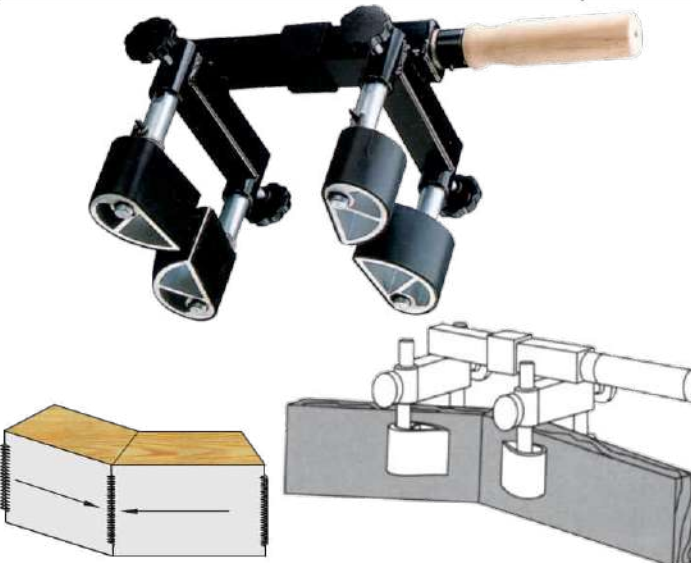

Zjednodušuje lepenie oblúkov okien z pripravených segmentov.

UPINÁK

302041

H	L	LT	Nr	€
34	55	160	6150702A24000	16,80
37	65	200	6150702A40000	17,80
51	95	262	6150702A60000	24,00
51	110	277	6150702A70000	29,75

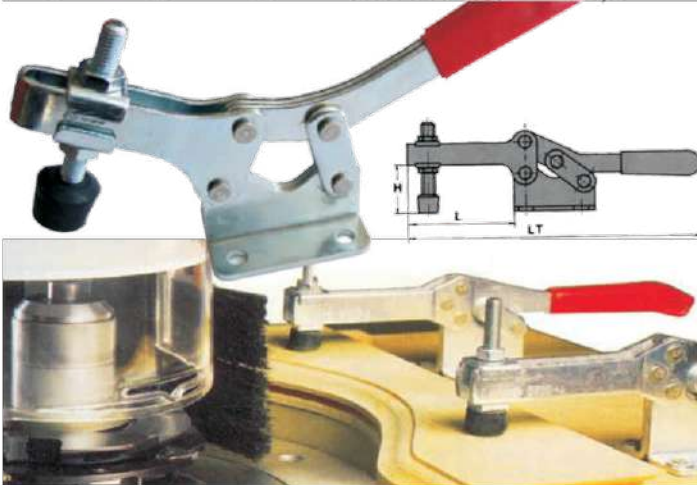

Upináky sa používajú pri aretovaní dielcov pri obrábaní na rôznych šablónach, alebo pri montáži. Na požiadanie dodávame i upináky pneumatické.

MONTÁŽNY VANKÚŠ

16,5x16,5cm	nosnosť 150 kg	Nr	€
		506DED06M01	7,75



Mimoriadne silný vankúš, dofukovaný ručne pre ustavenie okien, dverí...

ANGOLFAST

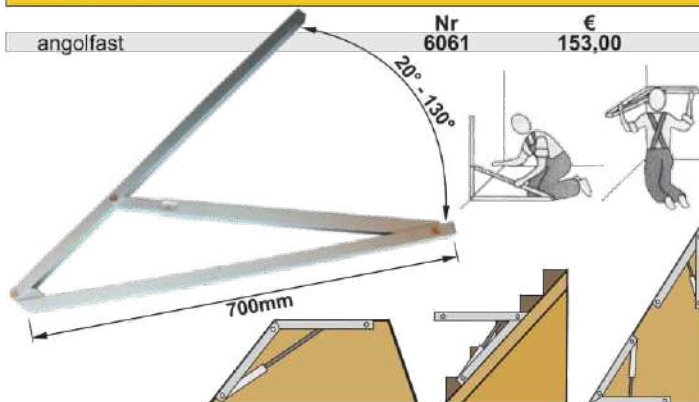

Angolfast sa používa pri zisťovaní a prenášaní rôznych uhlov, podľa hore uvedených príkladov. Uhly možno prípravkom zmerať a v aretovanom stave preniesť na iné miesto. V angolfaste je zabudovaná vodováha.

ŠABLONA NA SCHODY



15 pozinkovaných koľajníc v rôznych veľkostiach na vymeranie nástupníc. Stabilná, prenosná fixácia obrysu na fahky a bezchybný prenos

HLADAČ STREDU

Nr	€
360FC36	3,83



Pomôcka pre vyznačenie stredy okrúhleho i štvorcového prierezu obrobku.

FLEXI

L	Nr	€
1000 mm	360FC36	3,83



Flexi je pružný meter, ktorým odmeriame obrobky konvexných i konkávných tvarov.

RÁDIUS KRIŽ

Nr	€
606SPP040084	230,00



Pofahky zistíte rádius stavebného otvoru či starých výrobkov. Služí pri kontrole oblúkov.

PÁSKA MERACIA

L	Nr	€
1000 mm	4451995727	2,38



Kovová samolepiaca meracia páska 1m x 12,5mm. II. trieda presnosti s možnosťou kalibrovat'.

L	Nr	€
5000 mm	5012930902	12,67

Ploché prevedenie prispôbené na pilové stoly. Silné lepidlo zospodu a otvory umožňujú fahku montáž.

VLHKOMERY



meraný rozsah vlhkostný	MMV 530	WHT 740	WHT - 860	WHT - 770
	I 5 - 30%	I 5 - 30%	I 8 - 23%	I 7 - 23%
presnosť	II max. 2%	I max. 1%	II 21 - 90%	II 21 - 90%
	II max. 4%		I max. 1%	I max. 1%
meraný rozsah teplotný			II max. 3%	II max. 3%
napájanie	batéria 9V	batéria 9V	batéria 9V	batéria 9V
Nr	6011432	601007	601002	601003
€	240,00	275,00	324,00	349,00



PRÍSLUŠENSTVO

Nr	WS-10 zárazacia sonda	AW - 02 sonda na dýhy	Prepínač T8.2C	WT - 21 teplotná sonda
€	601004	601005	601010	601006
	56,00	42,00	55,60	323,00



DETEKTORY

DWD181ZJ	Makita	GMS 120	BOSCH	D-TEC 120	BOSCH	DE 0892G	DEWALT
18V aku	Nr 513DWD181ZJ	9V bat.	Nr 5110601081000	12V aku	Nr 5110601081300	9V bat.	Nr 1144DE0892G
	€ 1059,00		€ 107,50		€ 207,50		€ 120,00

Priemyselné detektory s rozsiahlou funkcionalitou, ktorých používaním predídete nečakaným ťažkostiam pri montážnych prácach.

LASERY

DIAL'KOMER 30m		KRÍŽOVÝ	SOLA	LÍNOVÝ	Z-LASER
	Nr	dĺžka laser	Nr		
Milwaukee	1144DW030PL	PLANO	50871017101440,83		
SOLA	50871025101	statív	50871120101 82,50		
Bosch	5110601072900				
	€ 29,17		€ 440,83		
	€ 74,17		€ 82,50		
	€ 90,83				

Spôhlivé dial'komery s rôznou počítanou funkcionalitou.

Zelený laser zameriava v troch osiach 3x360°.

Priemyselné lasery pre vyznačenie miesta rezu so zvýšenou odolnosťou.

POSUVNÉ MERADLÁ

DIGIT				DIGI			HĽBKOMER	
L	Nr	€	Nr	€	Nr	€	Nr	€
1500	6069501500	1 646,-	6069551500	1 828,-	6069901500	2 015,-	302GA1	5,75
2000	6069502000	1 833,-	6069552000	2 015,-	6069902000	2 202,-		
2500	6069502500	2 020,-	6069552500	2 242,-	6069902500	2 388,-		

Meradlo vonkajších rozmerov dielcov.

Meradlo vonkajších aj vnútorných rozmerov dielcov.

Meradlo vonkajších aj vnútorných rozmerov dielcov a roztečí otvorov.

DIGIT je dodávané v dĺžkach L 1500-2500mm, usposobené pre meranie roztečí, vonkajších a vnútorných rozmerov dielcov.

Posuvné meradlo s max. dĺžkou merania 150 mm.

Hĺbkomer slúži na nastavenie a odmeriavanie polohy stopkovej hornej frézy.

MERADLÁ

ODCHYLKOMER LIMIT		PROFILOMER		DĽŽKOMER CONTI		
stojan	Nr 501151280104	L	Nr	L	Nr	€
odchýlkomer	91028	150mm	360B19075	1000	606KM1000	541,00
	€ 16,58	250mm	360B190710	2000	606KM2000	591,00
			€ 4,90	3000	606KM3000	670,00
			€ 14,08	4500	606KM4500	887,00

Stojan s magnetickou základňou. Odchýlkomer z rozsahom 0-10mm.

Profil okopíruje obroby. Získané rozmery je možné preniesť.

Conti digitálne odmeriava dĺžky. Je možné ho dodatočne namontovať (svojpomocne) na rôzne typy zariadení (formátovacia, skracovacia píla...).



ZVINOVAČIE METRE

CITO SOLA ♦			TRI-MATIC SOLA ♦			PRO IRWIN <small>USA</small>			MAGNETIC Milwaukee		
dĺžka	Nr	€	dĺžka	Nr	€	dĺžka	Nr	€	dĺžka	Nr	€
5m	50871510101	102,50	3m	50850023201	11,00	3m	61210507790	5,71	5m	5034932464599	16,89
			5m	50850023301	19,08	5m	61210507791	9,33	8m	5034932464600	21,13
						8m	61210507792	15,46	10m	5034932464601	24,45



Digitálny zvinovací meter. Meria dĺžku v mm alebo cm.



I. trieda presnosti. Doporučujeme pre vnútrofremnú metrologiu.



ABS plastové púzdro odolné proti nárazu, praktický, kompaktný tvar.



Obzvlášť odolný. Pásmo sa neláme do jeho vysunutia 3,4m.

VODOVÁHY

MAGNET SOLA ♦			HORIZONT			DIGITAL RED SOLA ♦			TORPÉDO Milwaukee		
dĺžka	Nr	€	dĺžka	Nr	€	dĺžka	Nr	€	dĺžka	Nr	€
20cm	50801430601	6,33	40cm	44515004	11,63	60cm	50801735801	170,83	7,6cm	5034932472122	14,57
			50cm	44515005	12,67						
			60cm	44515006	13,75						
			80cm	44515008	15,79						
			100cm	44515010	17,92						
			120cm	44515012	15,00						
			150cm	44515015	23,25						
			180cm	44515018	26,83						
			200cm	44515020	29,58						



Plastová magnetická trojlibelová vodováha s dĺžkou 20cm.



Štandardná hliníková libela pre každého montážnika



Digitálna vodováha s možnosťou zaznamenania a prenosu uhlov.



Magnetická libela vhodná aj pre kovové konštrukcie.

UHLOMERY

OBLÚKOVÝ SOLA ♦			PRENOS UHLOV wolcraft			DIGI UHLOMER SOLA ♦			PRÍLOŽNÍK		
	Nr	€		Nr	€	dĺžka	Nr	€	dĺžka	Nr	€
GR 150	50857012101	22,33	30-180°	4486957	17,08	200mm	50856052301	32,92	750x35mm	32818799	28,75
GR 300	50857012301	59,83				500mm	50856052401	38,25			



Robustný chrómovaný uholník s aretáciou stupnice.



Vhodné na meranie a prenos uhlov pri skracovaní pokosovou pilou.



225° 3288823501 27,08

Uhlomer s LCD displayom, s možnosťou uloženia nameranej hodnoty.



Jednoduchý príložník pre stolárske práce.

UHOLNÍKY

3D wolcraft			STOLÁRSKE SOLA ♦			TESÁRSKE DEWALT			S DORAZOM		
dĺžka	Nr	€		Nr	€	dĺžka	Nr	€	dĺžka	Nr	€
5m	50871510101	102,50	300x145	50856014201-1	10,00	17,5cm	1144DWHT252270	19,58	300x180	513F858130	17,92
			400x210mm	3283327	5,83	30cm	1144DWHT252280	23,33	500x280	513F858150	31,79



Rozmanitú funkciu uholníka spoznajte na našom [eshope](#)



Obľúbený uholník s možnosťou odmeriavania dĺžky.



Rozmanitú funkciu uholníka spoznajte na našom [eshope.woodb.sk](#)



Štandardný uholník s dorazom pre prenos pravého uhla.

DIAMANTOVÝ VRTÁK - SUCHÉ VŔTANIE M14



ø D	upínanie	Nr	€
ø 6 mm	M14	5034932471759	16,18
ø 8 mm	M14	5034932471760	20,42
ø 10 mm	M14	5034932471761	17,82
ø 12 mm	M14	5034932471762	19,20
ø 14 mm	M14	5034932471763	19,66
ø 16 mm	M14	5034932471764	20,36



Hĺbka rezu 40mm, stopka šesťhranná. Na drevo, preglejku, oceľ, sádrokartón, plasty.

VŔTACIA KORUNKA SDS-PLUS TCT



ø D	ø D	Nr	€
50 mm	M16 x 2	5034932344479	37,05
65 mm	M16 x 2	5034932344480	48,61
68 mm	M16 x 2	5034932399099	50,43
82 mm	M16 x 2	5034932344481	53,61
90 mm	M16 x 2	5034932344482	68,39



Na vŕtacie kladivá s hmotnosťou do 4 kg. Korunky TCT majú závit M16 x 2 a sú vhodné na upínacie trne SDS-Plus a Hex 11.

NASTAVITEĽNÉ DIEROVAČKY

upínanie	hĺbka rezu	Nr	€
ø 45 - 90 mm	30 mm	4485977	31,10
ø 45 - 130 mm	30 mm	4485978	35,75



Na sádrokartón, OSB dosky, mäkké drevo a preglejku, na všetky bežné rozmery. Plynule nastavenie v troch krokoch.

	Nr	€
3x náhradné brity	...5979000	xxx

Náhradné brity, pre sádrokartón, OSB, drevo.

DIEROVACIE SÚPRAVY

súprava	obsah sady	Nr	€
sanita	ø 25, 35, 43, 54, 83 mm	4485422	48,99
elektro	ø 40, 54, 65, 68, 74, 86 mm	4485423	63,22



sanita

elektro

Na drevo, preglejku, oceľ, farebné kovy, plasty a sádrokartón. Materiál BIM, v plastovom kufrí.

VŔTACIE DIEROVAČKY

PROFESIONÁLNE	rozмеры	Nr	€
	ø 60, 68, 74, 80, 95 mm	4482155	24,50



- pre vysoký výkon, listy vyrobené z wolfrámovej ocele
- na drevo, sádrokartón, stavebné dosky, neželezné kovy

REMESELNÉ	rozмеры	Nr	€
	ø 25, 32, 38, 45, 50, 56, 62mm	511260858406	15,83



Remeselný vykružovák s kovovým telom. Na drevo, sádrokartón, stavebné dosky.

DIAMANTOVÝ VRTÁK - SUCHÉ VŔTANIE M14



súprava DIA vŕtákov	Nr	€
ø D 6; 8; 10; 14	5034932471863	62,42



Vyvinuté špeciálne pre profesionálov, ktorí potrebujú vŕtať do extrémne tvrdých materiálov.

VRTÁK DIAMOND PLUS



ø	Nr	€	ø	Nr	€
5	50349560503	14,82	29	50349565615	14,11
6	50349560505	14,82	32	50349565620	15,02
8	50349560507	15,07	35	50349565625	15,73
12	50349560511	22,08	38	50349565630	17,11
15	50349560513	21,86	44	50349565640	19,66
20	50349560515	23,57	51	50349565645	19,91
22	50349565605	12,02	68	50349565664	25,00
25	50349560517	25,27			



Na drevo, preglejku, oceľ, farebné kovy, plasty a sádrokartón.

DREZOVÝ VYKRUŽOVÁK

vykružovák	ø	Nr	€
vykružovák 32	ø 32 mm	1177779	18,50
vykružovák 35	ø 35 mm	1171223	20,33



Vykružovák na otvory v drezoch pre vodovodné batérie. Jednoduché, presné vyrezávanie, na plechy a nerez.

UHLOVÝ SKRUTKOVAC FLEXI

s flexibilnou stopkou	dĺžka 289 mm	Nr 4481236	€ 12,24
-----------------------	-----------------	---------------	------------



S flexibilnou stopkou s magnetom sa dostanete aj na zle dostupné miesta

RUČNÝ KUŽELOVÝ ZÁHLBNÍK

ø 16 mm	dĺžka 140 mm	Nr 4501039524	€ 11,33
---------	-----------------	------------------	------------



Na drevo, s plastovou rukoväťou, z nástrojovej ocele HSS.

UHLOVÝ NÁSTAVEC OSD2



OSD2 (do 40 Nm)	Nr 5034932352320	€ 68,25
-----------------	---------------------	------------



Pravouhlý nástavec na skrutkovanie-vrtanie v obmedzených priestoroch.

PRAVOUHLÁ SKRUTKOVACIA HLAVA

DT20503 IMPACT	Nr 1144DT20503	€ 20,75
----------------	-------------------	------------



4 plastové čepele na obzvlášť citlivé povrchy v 2 stupňoch tvrdosti.

PRÍKLEPOVÝ PRAVOUHLÝ NADSTAVEC

sada SHOCKWAVE	Nr 5034932471274	€ 19,79
----------------	---------------------	------------



Na skrutkovanie, vrtanie v obmedzených a ťažko prístupných oblastiach.

NADSTAVEC S HLAVOU PRAVOUHLÝ SKRUTKOVACÍ

flexi koncovkou 3in1	Nr 1144DT20502	€ 32,32
----------------------	-------------------	------------



3v1 použitie – flexi predĺženie, uhlový adaptér, flexi uhlový adaptér.

SADA NEBOŽIECOV 4KS

rozmery 2,3,4,5 mm	Nr 4451990253	€ 2,00
-----------------------	------------------	-----------



Pre ručné predvrtávanie dier do dreva v pravotočivom vyhotovení.

RYSOVACIA IHLA

L=150 mm	Nr 44513281	€ 2,25
----------	----------------	-----------

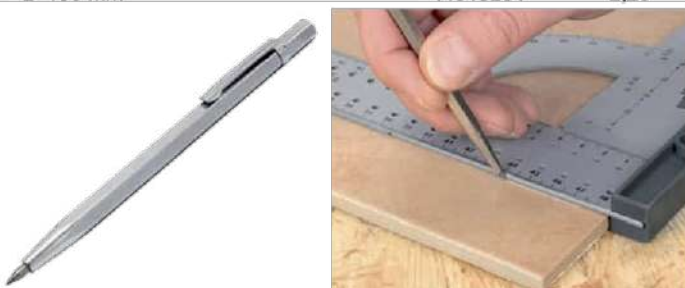

Rysovacia ihla s hrotom z tvrdokovu, šesťhranná s klipom, dĺžka 150mm.

FIXKY - POPISOVAČE

INKZALL značkovač čierny 1mm	Nr 50348223100	€ 1,13
------------------------------	-------------------	-----------



značkovač DHM SOLA5 - 1.5 mm	50866071120-1	4,46
------------------------------	---------------	------



popisovač TWIN; čierny 1mm a 0,5mm	612S0811100	2,38
------------------------------------	-------------	------



CERUZKY

ceruzka do hlbokých otvorov TLM2 SOLA	Nr 5133030	€ 9,67
ceruzka tesárska Pica	50866041120-1	8,93



TECHNICKÁ FRÉZA DO DREVA

ø D	prac.dĺžka	dĺžka	Nr	€
ø 6 mm	60 mm	90 mm	4482512	7,20



Účinný nástroj pre vrtanie a súčasné frézovanie.

ŠKRABKA

čepel 61 mm	Nr	€
	4484193	10,85



Na odstránenie lakov, farieb, nerovností a nálepiek z hladkých plôch.

TECHNICKÁ FRÉZA DO SÁDROKARTÓNU

ø D	prac.dĺžka	dĺžka	Nr	€
ø 8 mm	35 mm	c	4487981	6,20

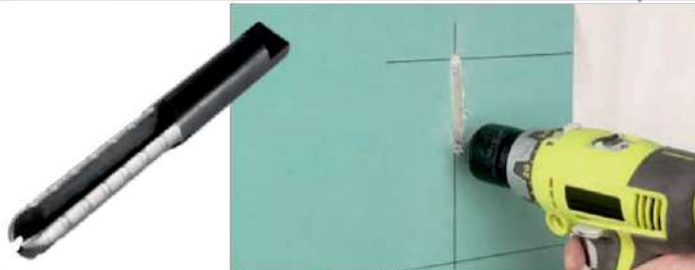

Na frézovanie obrysov a otvorov do dlažieb. Diamantový nástroj umožní vytvoriť atypické otvory.

ŠKRABKA

čepel 61 mm	Nr	€
	4484287	2,95



4 plastové čepele na obzvlášť citlivé povrchy v 2 stupňoch tvrdosti.

TECHNICKÁ FRÉZA DIA - DO DLAŽBY

ø D	dĺžka	Nr	€
ø 6 mm	100 mm	4487982	11,85

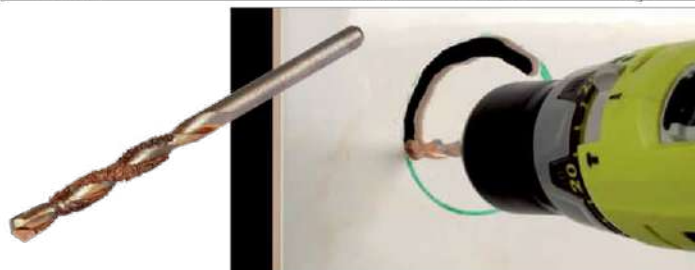

Na frézovanie obrysov a vrtanie otvorov, napr. na rozperky do SDK. 3 brity s upínacími zalomenými drážkami zaisťujú rýchle frézovanie.

CIDLINA OBŤAHOVACIA

50x150x0,8 mm	Nr	€
	4450360583	1,33

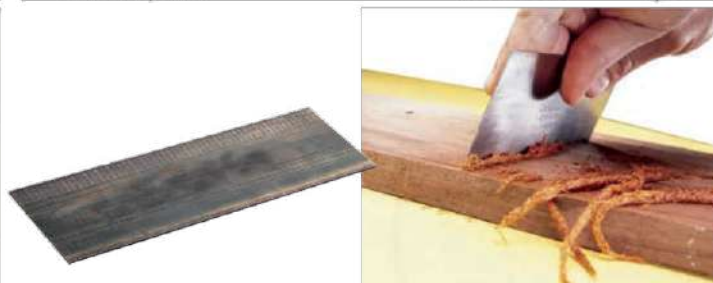

Pre zráženie hrán a vyrovnávanie povrchu.

VYKRUŽOVAČ KRUŽIDLO

rozsah 0-220 mm	Nr	€
	4484151	5,45

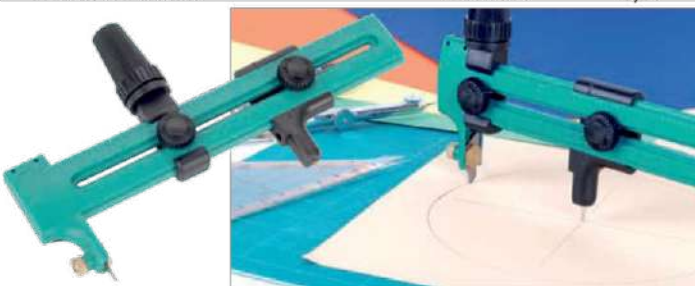

Pre vykružovanie kože, papiera, fólie, dýhy.

LAPAČ PRACHU SDS-Plus

DUST TRAP	Nr	€
	5034932464916	22,91



Univerzálne nasadenie. Na všetky značky vrtacích kladív SDS-Plus.

OTOČNÝ NŮŽ

Nôž vykružovací	Nr	€
	4484152	5,73

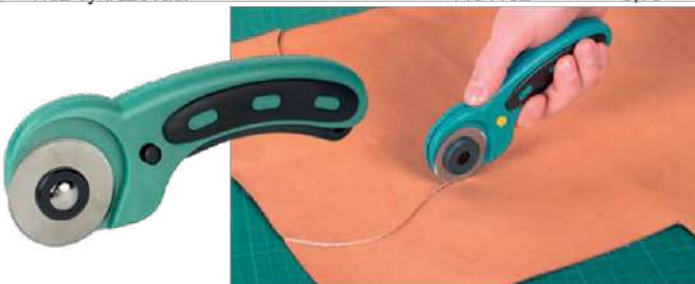

Pre rovné a zakrivené rezanie látky, papiera.

ZBERAČ PRACHU GUMOVÝ

pre ø 5 - 8 mm	Nr	€
	5034932430912	3,73



Zvon na zachytávanie prachu. Zachytáva prach pri vrtaní nad hlavou.

LODIČKY

drevina	Nr	€
smrek (picea)	302070SMB	52,50 / 1 000ks
dub (quercus)	302070DBB	49,00 / 500ks
buk (fagus)	302070BKB	30,83 / 500ks



Ponúkané lodičky sa používajú pri vyspravovaní zásmolkov a trhlín. Pri ich aplikácii je potrebné osobitné zariadenie na lodičkové frézy. Lodičky dodávame na objednávku v rôznych drevinách.

DREVENÉ TYČE hladké, vrúbkované

ø D	L	Nr hladké	Nr vrúbkované	€
6	1000	3020601	3020602	0,46
8	1000	3020614	3020613	0,50
10	1000	3020620	3020622	0,67
12	1000	3020633	3020631	0,92
14	500		3020641	0,67
15	1000	302067		1,67
16	500		3020655	0,68



Egalizované bukove tyče vo vyhotovení hladké a vrúbkované. Vhodné pre konštrukčné spoje.

MULTILODIČKY

šírka	dĺžka	Nr	€	šírka	dĺžka	Nr	€
F20	70	399FE700005	0,55	F35	70	399FE700240	1,89
F20	150	399FE700070	0,82	F35	150	399FE700100	2,35
F20	300	399FE700075	1,75	F35	300	399FE700105	4,53
F20	500	399FE700080	3,25	F35	500	399FE700110	6,12
F24	70	399FE700083	0,78	F42	70	399FE700250	2,12
F24	150	399FE700085	1,10	F42	150	399FE700115	2,89
F24	300	399FE700090	2,02	F42	300	399FE700120	5,12
F24	500	399FE700095	4,23	F42	500	399FE700125	7,85



KOLÍKY

ø D	L	Nr	€ / 1000ks
6	40	302071B	7,58
8	40	302072B	9,08
10	40	302073B	14,17



Egalizované bukove kolíky pre konštrukčné spoje, balené po 1000 ks.

ZÁTKY

ø D	Nr	€ / 500ks
35,2	302053B	24,83
30,2	302054B	21,08
25,2	302055B	20,00
20,2	302056B	16,25
15,2	302057B	15,83



Zátky sa používajú pre vyspravovanie nezdravých a vypadávajúcich hŕč. Zátky sú vyhotovené z konárov stromov, čím zvyšujú imitačnú schopnosť náhrady zdravých sukov. Vyhotovujú sa zo smreka resp. jedľa, a dodávajú sa pri vlhkosťi 10 až 12%.

HOFFMANN

	Nr	€
plast W1/6	514W9100600-1	2,50
plast W2/14	514W9201400-1	2,92
plast W2/15,8	514W92015001-1	2,92
plast W3/15,8	514W9301500-1	4,83
plast W3/31,7	514W9303100-1	6,25

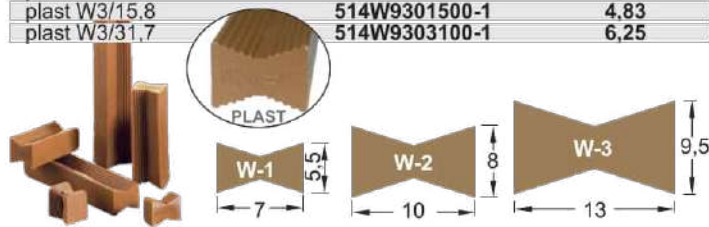

Rybinový spojovací systém pre konštrukčné spoje. Rybiny sú dodávané v plastovom i preglejkovom vyhotovení, imitujúc pôvodné priznané spoje.

DOMINO DREVENÉ

H x L	balenie	Nr	€
5x30	300ks	510493296-1	14,17
6x40	190ks	510493297-1	14,17
8x40	130ks	510493298-1	14,17
8x50	100ks	510493299-1	15,42
10x50	85ks	510493300-1	14,58
12x100	50ks	510498216	21,67
14x140	35ks	510498219	24,17

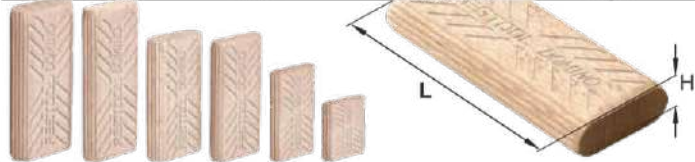

Mnohostranný, stabilný a rýchly spojovací systém pre konštrukčné spoje

DREVENÉ ZÁSLEPKY

€/ 20ks	Nr	ø8	ø10	ø15	ø20	ø25	ø30
smrek	302S(08~30)	x	4,00	4,00	4,50	4,80	5,50
dub	302D(08~30)		4,00	4,00	4,50	4,80	5,50
buk	302B(08~30)		4,00	4,00	4,50	4,80	5,50
borovica	302O(08~30)		4,00	4,00	4,50	4,80	5,50



Nábytkárske drevené záslepky pre blendovanie otvorov.

DREVENÉ ZÁSLEPKY - TVAROVÉ

ø D	H x ød	Nr	€	ø D	H x ød	Nr	€	ø D	H x ød	Nr	€
22	15 x 15	399FE710875	9,21	18	8 x 10	399FE710885	8,56	25	22 x 15	399FE710990	10,45
				22	13 x 15	399FE710890	9,05	30	25 x 15	399FE710995	12,50

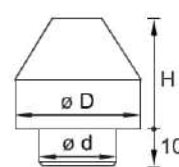
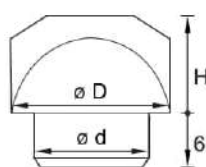
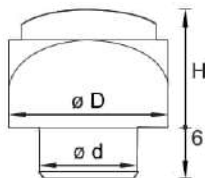

Záslepky používané v tesárstve pre imitáciu pôvodných konštrukcií. Balené po 50ks. Pre osadzovanie odporúčame PUR lepidlo.

LAMELY DREVENÉ

rozmer	Nr	€/ 1000ks
20 originál	30207820	40,00
10 originál	30207710	40,00



Originálne lamely na konštrukčné spoje, balené po 1000 ks.

LAMELY C20 PRIEHLADNÉ

TYP	Nr	€/ 80ks
C20	513145010	16,00

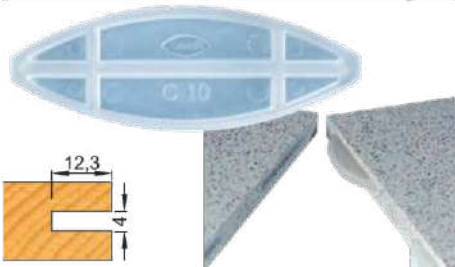

Z bieleho priesvitného plastu rozmeru Lamely 20. Pre pevné spoje, odolné aj voči navlhnutiu.

SIMPLEX

rozmer (d x š x v)	Nr	€/ 50ks
54x23x4,1mm	513166100	60,00

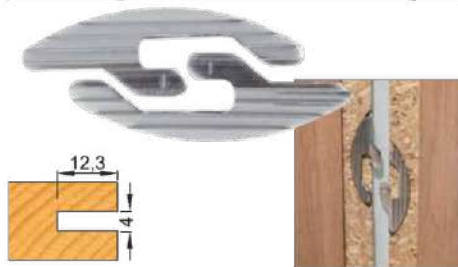

2 - dielny odvesiteľný spojovací prvok pre clony, regály, dvojité dvere atď.

FIXO E20 H

rozmer (d x š x v)	Nr	€/ 80ks
23x28x4 mm	513145026	17,33



Samostatňovacie lamely, rebrovanie spôsobí, že zatlačím sa spojenie stiahne.

FIXO E20-L

rozmer (d x š x v)	Nr	€/ 80ks
56x11,5x4 mm	513145027	17,33



Samostatňovacie lamely, rebrovanie spôsobí, že zatlačím sa spojenie stiahne.

K20

rozmer (d x š x v)	Nr	€/ 80ks
60x24x4,5 mm	513145000	23,33

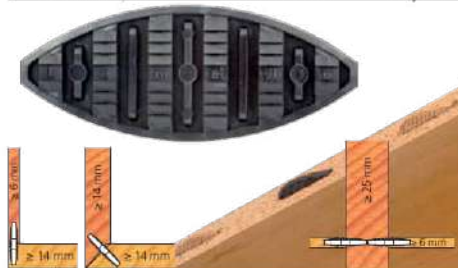

Pre spoje, ktoré sa ťažko upevňujú. Drží časti pohromade, pokiaľ nezaschne lepidlo.

CLAMEX P-10

rozmer (d x š x v)	Nr	€/ 50ks
52x19x9,7 mm	51314538700	60,92



Rozoberateľný spájací prvok nábytku, pre hrúbky materiálu od 12mm.

CLAMEX P-14/10 MEDIUS

rozmer (d x š x v)	Nr	€/ 80ks
64x13,5x9,7 mm	513145357-80	114,09

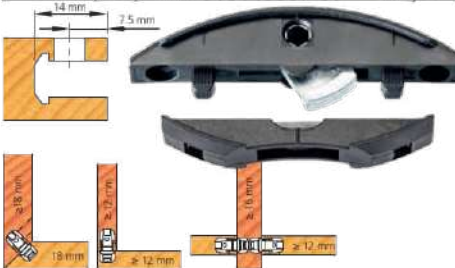

Pevný rozoberateľný spájací prvok nábytku, pre hrúbky materiálu od 16mm.

CLAMEX P-14

rozmer (d x š x v)	Nr	€/ 50ks
64x27x9,7 mm	513145356	60,92



Pevný rozoberateľný spájací prvok nábytku, najmenší ovládací otvor D6mm.

CLAMEX P-14/10 FLEXUS

rozmer (d x š x v)	Nr	€/ 80ks
64x13,5x9,7 mm	513145315	114,09



Rozoberateľný spájací prvok nábytku s flexibilným polohovacím čapom.

BISCO P-14

rozmer (d x š x v)	Nr	€/ 40ks
65x27x7 mm	513145303	11,83

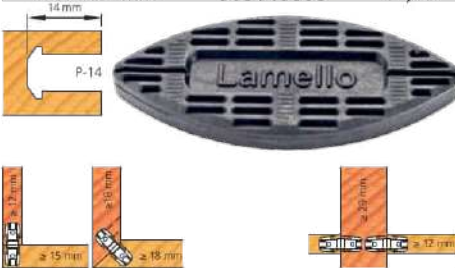

Vyrovnávacie lamely vhodné pre Clamex P-14 a Tenso P-14.

BISCO P-10

rozmer (d x š x v)	Nr	€/ 80ks
52x19x7 mm	513145304	23,60

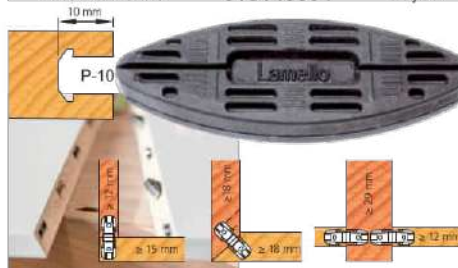

Vyrovnávacie lamely vhodné pre Clamex P-10 a Tenso P-10.

TENSO P-14

rozmer (d x š x v)	Nr	€/ 50ks
66x27x9,7mm	51314543500	38,33



Samoupínací spojovací článok na lepenie tenkých obrobkov o hrúbke materiálu 16mm.

TENSO P-10

rozmer (d x š x v)	Nr	€/ 50ks
52x19x9,7mm	51314543800	44,08



Samoupínací spojovací článok na lepenie tenkých obrobkov o hrúbke materiálu 12mm.

DIVARIO P-18

rozmer (d x š x v)	Nr	€/ 80ks
23 x 28 x 4 mm	513145550	86,00

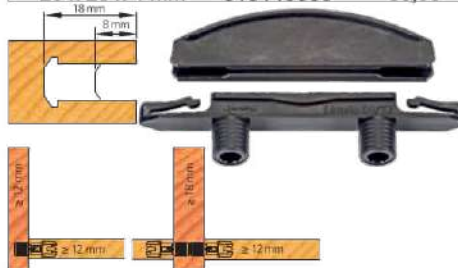

Samoupínací, neviditeľný spájací prvok na zasunutie. Tiež rozoberateľný.

ELOX FARBY	
1.	Strialbno
2.	Bronz svetlý
3.	Bronz tmavý
4.	Elektro
5.	Sallox
6.	Bielá
7.	Bronz sried
8.	RA

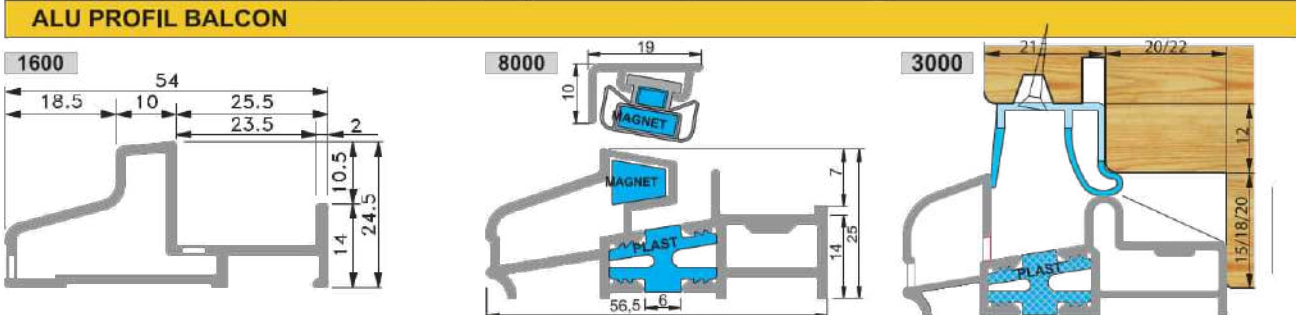
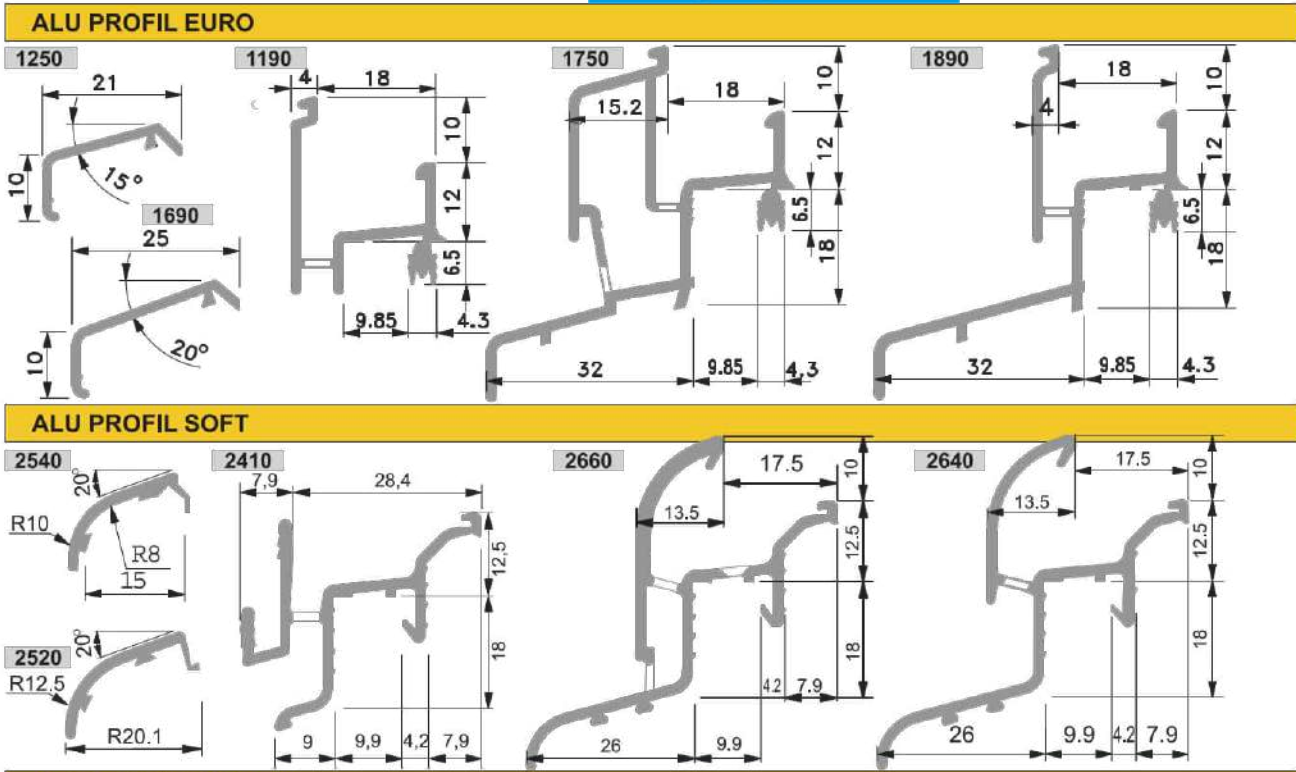

SI 8132 MAGNETICKÉ TESNENIE

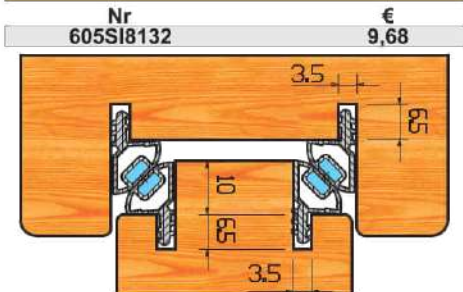

146 DVEROVÉ TESNENIE

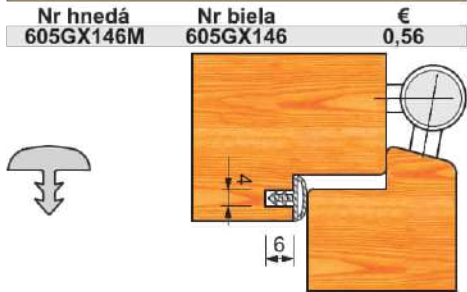

001;2;3 DVEROVÉ TESNENIE

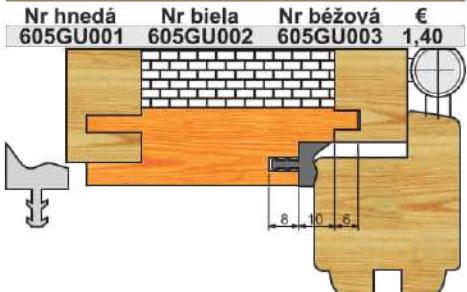

020 OKENNÉ TESNENIE

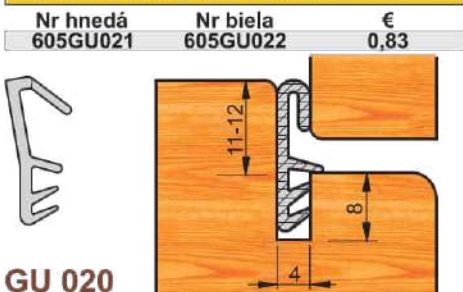

080 ZVUKOVÉ TESNENIE

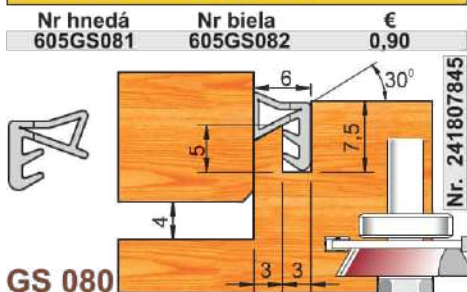

A 219 DVEROVÁ ŠTETINA

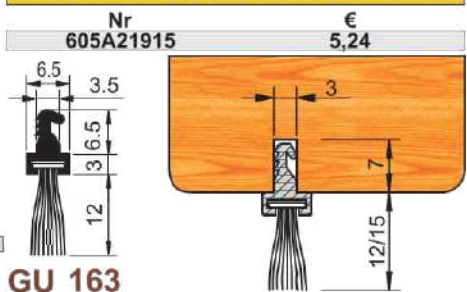

040 OKENNÉ TESNENIE

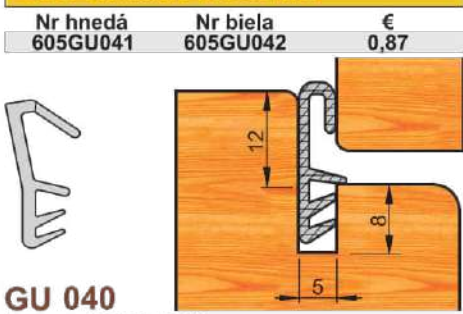

250 OKENNÉ TESNENIE

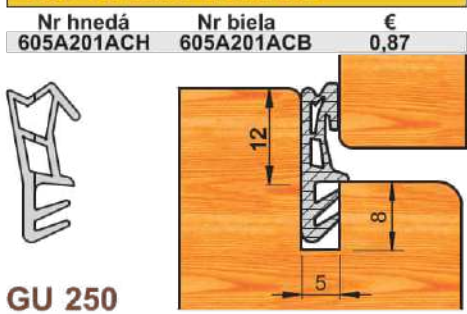

070 OKENNÉ TESNENIE

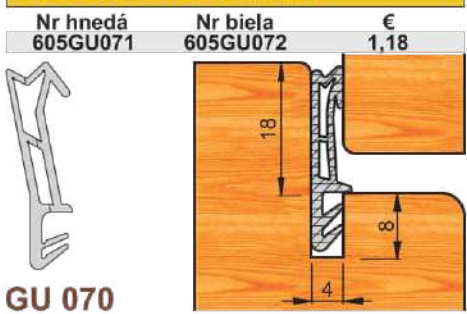

OZDOBNÉ KLINCE



Ponúkame široký sortiment rozmerov, tvarov a materiálov ozdobných klincov a stripov. Vyžiadajte si samostatný katalóg s cenami.

PRIEMYSELNÉ SPOJOVAČE

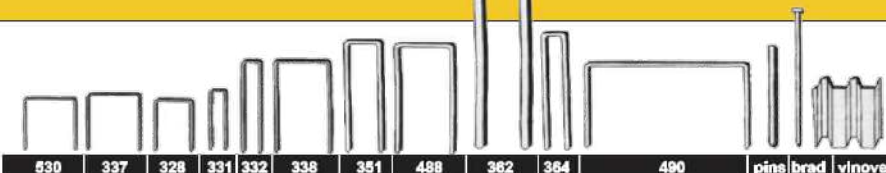
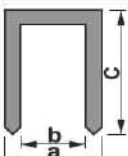

TYP	Priemer	a	b	c	N	O	Povrch. Úpr.	Použitie
530	0,71	11,4	10,2	4; 6; 8; 10; 12; 14				Bosch PTK 14, 19, 28
337	0,71	12,65	11,45	5; 8; 10; 12	*		Zn	
328	0,71	9	7,82	4; 5; 6; 7; 8; 10; 12; 14	*	*	Zn, L	
331	0,8	4,6	3,19	6; 8; 10; 12	*	*	Zn, L	Nikema ML1080/16
332	0,8	5,2	3,81	10; 12	*	*	Zn, L	
338	0,84	12,95	11,45	4; 5; 6; 7; 8; 10; 12; 14; 16	*	*	Zn, L	Nikema ML1080/16, ML10 BL50 80/16
342	1	12,8	11,45	8; 10; 12; 14; 16	*	*	Zn	
352	1,2	8,8	6,75	13; 15; 18; 20; 25; 30; 35; 40	*	*		Nikema ML1592/25, ML20 92/32, ML40 92/40
363	1,4	10,6	8	15; 18; 20; 25; 30; 35; 40; 45; 50; 60; 64	*	*	Zn, L	Nikema M50 363
364	1,18	5,6	3,5	10; 12; 15; 20; 25; 30; 35; 40	*	*		Nikema M18 COMBI/40
367	1,53	10,8	8	18; 20; 25; 30; 35; 40; 45; 50; 60; 64	*	*		
378	2	21,8	17,7	12	*	*		
489	1,18	13,60	11,45	10; 12; 16; 20; 25	*	*		
490	1,7	34,20	32,20	14; 15; 16; 18; 19; 22	*	*		
491	1,53	25,10	22,35	16; 20; 25; 30; 35	*	*		Nikema M42 AK/40
496				9,5	*	*		

Distribuuje kompletný sortiment priemyselných spojovačov, vlnovcov a klincov. Vyžiadajte si vzorky a cenovú ponuku.

PIESTOVÉ KOMPRESORY

výkon l/min.	vzdušník	Nr	€
150	50L	600K80250050	290,83
300	100L	600K81350100	616,67
370	200L	600B3800B200CT4	799,00
740	270L	600K82750270	1 524,17



Spofahlivý, výkonný piestový kompresor so vzdušníkom.

SKRUTKOVÉ KOMPRESORY

model	výkon l/min.	vzdušník	Nr	€
KVE 8-270	760	270	600K52008270	4 521,67
KVE 10-270	900	270	600K52010270	5 139,17
KVE 8-270 so sušičom	760	270	600K52008271	5 757,50
KVE 10-500 so sušičom	1 050	500	600K52010501	6 890,83
KVE 15-500 so sušičom	1 610	500	600K52015501	7 818,33



Dielský supertichý skrutkový kompresor so vstrekaním oleja.

VZDUŠNÍKY

objem / lit.	Nr	€
270	60050000270	405,-
500	60050000500	1 083,-
900	60050000900	1 436,-



Zaradenie vzdušníka do tlakového systému zabezpečí stabilitu dodávok vzduchu spotrebičom.

ÚPRAVA VZDUCHU

prietok l/min.	Nr	€
500	60021031000	635,83
1000	600210610000	884,00
1700	60021140000	1 207,50



Zaradenie sušičky, ktorá zbavuje vzduch vlhkosti predlžuje životnosť spotrebičov.

FILTRE VZDUCHU

prietok l/min.	Nr	€
1 800	60009500180	54,00
5 000	60009500200	60,00



Vysoko účinná filtrácia redukčným ventilom s filtrom - odkalovačom a primazávačom.

HADICE ŠPIRÁLOVÉ

poloprofi	tlak	Nr	€
8x6	6m	10 60031100610	18,83
8x10	10m	10 60031100810	20,83
8x10	15m	10 60031100815	26,58
PU profi	tlak	Nr	€
10x6,5	8m	12 60032000608	27,50
8x12	5m	12 60032000808	33,29



OLEJOVANIE VZDUCHU

	Nr	€
minerálny 0,5l	60090050100	4,96
primazávač 0,5l	60090500032	4,83



HADICE PNEUMATICKÉ

ø mm	L	m	tlak	Nr	€/ks
12	5	16	60030600605		12,08
15	10	16	60030600910		18,33
19	10	16	60030601310		22,50



Výkonné, odolné polyuretánové hadice pre rozvod tlakového vzduchu.

MODEL ML10 TYP 80/16

(g)	TYP, dĺžka spony	Nr	€
900	338 5-16mm	491 A 710 000 A09	206,69
900	331 6-12mm	491 A 710 000 A23	220,64

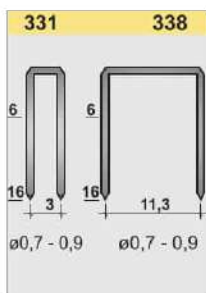

Táto pneumatická pištoľ je určená predovšetkým pre **čalúnnicke** práce. Lhká ergonomická konštrukcia a vysoká technická úroveň vyhotovenia ju predurčujú pre priemyselnú prax.

Potrebný príkon stlačeného vzduchu - 0,6 MPa. Kapacita zásobníka na 120/200 spôn. Táto pištoľ sa dodáva i pre spony typ - 331, 328.

MODEL ML10 BL50 TYP 80/16

(g)	TYP, dĺžka spony	Nr	€
1000	331 5-16mm	491 A 710 000 D01	301,34

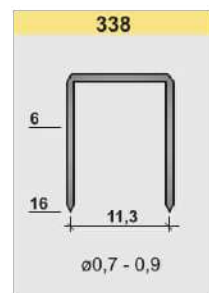

Táto pneumatická pištoľ je určená predovšetkým pre **čalúnnicke** práce. Lhká ergonomická konštrukcia a vysoká technická úroveň vyhotovenia ju predurčujú pre priemyselnú prax.

Potrebný príkon stlačeného vzduchu - 0,6 MPa. Kapacita zásobníka na 120/200 spôn. Táto pištoľ sa dodáva i pre spony typ - 331, 328.

MODEL M18 TYP COMBI/40

(g)	TYP, dĺžka spony	TYP klinca, dĺžka	Nr	€
1150	364 15-40mm	GF 15-40mm	491 A 718 000 U03	350,00

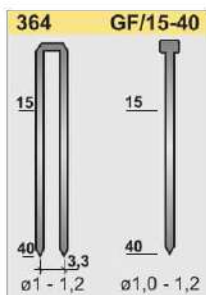

Táto pneumatická pištoľ je určená predovšetkým pre ľahké stolárske konštrukčné spoje pri montážach. Svojou univerzálnosťou vytvára dobré predpoklady pre široké uplatnenie.

Jednoduchá zmena náplní z klinčekov na spony a naopak umožňuje rozmanité použitie.

MODEL M10 SIC MINI GMG/30

(g)	TYP	dĺžka	Nr	€
900	mini pins	12-18mm	491 A 710 000 M04	386,83

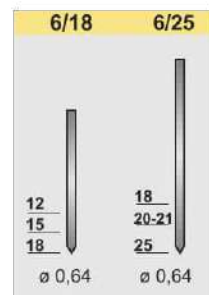

Táto pneumatická pištoľ je určená predovšetkým pre **lištovanie**. Lhká ergonomická konštrukcia a vysoká technická úroveň vyhotovenia ju predurčujú pre priemyselnú prax. Potrebný príkon stlačeného vzduchu je 0,6 MPa. Kapacita zásobníka na 140/180 pins.

MODEL M10 TYP MG/30 - TYP MG/40

(g)	TYP, dĺžka spony	Nr	€
MG 30	1150 MG8 15-30mm	491 A 710000 M09	370,00
MG 40	1300 MG8 25-40mm	491 A 710000 N03	427,67

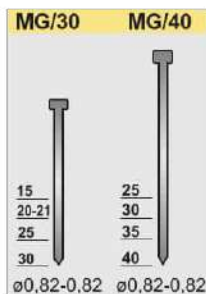

Táto pneumatická pištoľ je určená predovšetkým pre **lištovanie a ľahké konštrukčné spoje**. Lhká ergonomická konštrukcia a vysoká technická úroveň vyhotovenia ju predurčujú pre priemyselnú prax.

Potrebný príkon stlačeného vzduchu - 0,6 MPa. Kapacita zásobníka na 60 klinčekov.

MODEL M15 SIC TYP 92/25

(g)	TYP, dĺžka spony	Nr	€
1250	352 15-25mm	491 A 715 000 B03	354,17

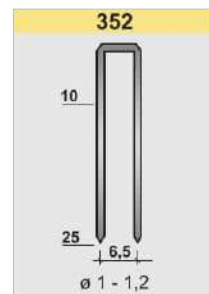

Táto pneumatická pištoľ je určená predovšetkým pre **stolárske konštrukčné spoje** - pre upevňovanie chrbátov skrií. Lhká ergonomická konštrukcia a vysoká technická úroveň vyhotovenia ju predurčujú pre priemyselnú prax.

Potrebný príkon stlačeného vzduchu - 0,6 MPa. Kapacita zásobníka na 120 spôn. Tento model sa dodáva tiež pre spony 364.

MODEL M18 TYP 92/32

(g)	TYP, dĺžka spony	Nr	€
1350	352 15-30mm	491 A 718 000 A03	294,00

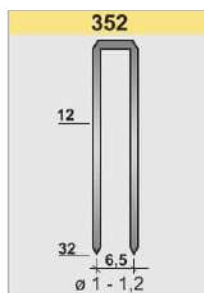

Táto pneumatická pištoľ je určená predovšetkým pre ľahké **stolárske konštrukčné spoje**. Ľahká ergonomická konštrukcia a vysoká technická úroveň ju predurčujú pre priemyselnú prax. Potrebný príkon stlačeného vzduchu - 0,6 MPa. Kapacita zásobníka na 120 spŕn. Tento model sa dodáva tiež pre spony 364. Model patrí medzi najvýkonnejšie pištole vo svojej triede, s ohľadom na rozmery hmotnosť a dĺžku nástrelnéj spony.

MODEL M40 TYP92/40

(g)	TYP, dĺžka spony	Nr	€
2100	352 15-40mm	491 A 740 000 A10	557,95

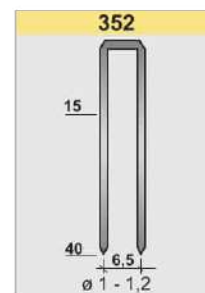

Táto pneumatická pištoľ je určená predovšetkým pre ľahké **stolárske konštrukčné spoje**. Stredne ťažká ergonomická konštrukcia a vysoká technická úroveň ju predurčujú pre priemyselnú prax. Potrebný príkon stlačeného vzduchu - 0,7 MPa. Kapacita zásobníka na 120 spŕn. Tento model sa dodáva tiež pre spony 364.

MODEL M50 TYP 363 - PINS/50

(g)	TYP, dĺžka spony	Nr	€
2450	363 25-50mm	491 A 750 000 A06	716,60
2450	6F 25-50mm	491 A 650 000 K01	645,00

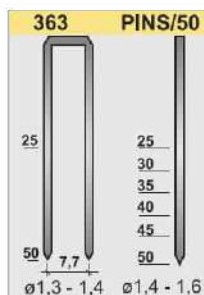

Táto pneumatická pištoľ je určená predovšetkým pre náročné **stolárske konštrukčné spoje**. Masívna ergonomická konštrukcia a vysoká technická úroveň vyhotovenia ju predurčujú pre priemyselnú prax. Potrebný príkon stlačeného vzduchu - 0,8 MPa. Kapacita zásobníka na 140 spŕn. Model patrí medzi ťažké pištole vo svojej triede, s ohľadom na rozmery hmotnosť a dĺžku nástrelnéj spony.

MODEL M42 TYP AK/40

(g)	TYP	dĺžka spony	Nr	€
2700	491	20-35mm	491 A 742 000 A03	763,88

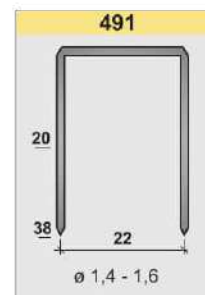

Táto pneumatická pištoľ je určená predovšetkým pre tesárske práce - **upevňovanie asfaltových šindľov na strechy**. Robustná konštrukcia a vysoká technická úroveň vyhotovenia ju predurčujú pre priemyselnú prax. Potrebný príkon stlačeného vzduchu - 0,8 MPa. Kapacita zásobníka na 120 spŕn.

MODEL M42 TYP F3-15

(g)	TYP, dĺžka spony	Nr	€
2350	F/3 12-15mm	491 A 642 000 U01	537,00

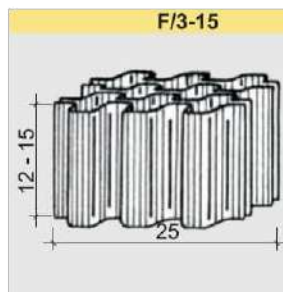

Táto pneumatická pištoľ je určená pre **náročné konštrukčné stolárske spoje**. Potrebný príkon stlačeného vzduchu - 0,8 MPa. Kapacita zásobníka na 75 spŕn.

MODEL M90 TYP RNS/90

(g)	TYP, dĺžka spony	Nr	€
3700	páskovaný 60-90mm	491 A 690 000 K01	666,00

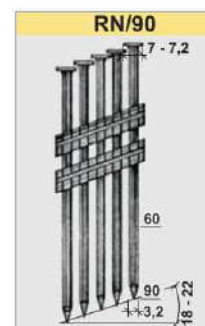

Táto pneumatická pištoľ je určená predovšetkým pre **debnárske a paletárske klincované spoje**. Potrebný príkon stlačeného vzduchu - 0,8 MPa. Kapacita zásobníka na 65 klincov. Klince sa dodávajú páskované vo vyhotovení ako hladké, krútené a konvexné.

PIZZI
 Nr 5209001 720,-€



B	Nr	€
72	5200072G	161,-
120	5200120G	170,-
150	5200150G	173,-
180	520A180G	161,-



1

Nr 5200063 45,-€



stojan

20

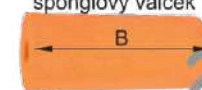

B	Nr	€	B	Nr	€
72	5200040	25,-	120	5209941	30,-
120	5200041	27,-	150	5209950	32,-
150	5200042	28,-	180	5209942	33,-
180	5200050	29,-			

gumený valček špongiový valček

2

B	Nr	€
72	5200034	197,-
120	5200035	208,-
180	5200036	233,-

14

Nr 5200002 109,-€



3

Nr 5200004	ø6x20	28,-€
Nr 5200005	ø8x25	28,-€
Nr 5200006	ø10x30	28,-€
Nr 5200007	ø12x40	28,-€



kolíky

22

Nr 5200078 316,-€

ATYP na zákazku



15

Nr 5200003 12,-€



4

Nr 5200008	ø6x20	84,-€
Nr 5200009	ø8x25	84,-€
Nr 5200010	ø10x30	84,-€
Nr 5200011	ø12x40	84,-€

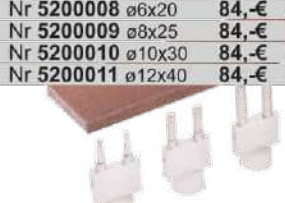

kolíky

10

Nr 5200079 350,-€

ATYP na zákazku



16

Nr 5200016	od 10 do 30mm	76,-€
Nr 5200017	od 20 do 40mm	82,-€



5

Nr 5200012	ø6x20	118,-€
Nr 5200013	ø8x25	118,-€
Nr 5200014	ø10x30	118,-€
Nr 5200015	ø12x40	118,-€



kolíky

11

Nr 5200053 480,-€

ATYP na zákazku



17

Nr 5200054 113,-€



lamely

6

Nr 5200021	100x30x6	98,-€
Nr 5200022	100x40x6	98,-€
Nr 5200023	100x50x6	98,-€



čap

12

Nr 5200295	100,-€
Nr 5200195	100,-€
Nr 5200095	100,-€

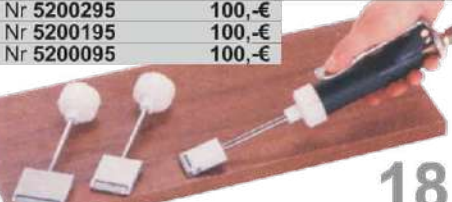

18

Nr 5200154 125,-€



lodičky

7

Nr 5200018	100x30x6	104,-€
Nr 5200019	100x40x6	104,-€
Nr 5200020	100x50x6	104,-€



dlab

13

Nr 5200029 347,-€

ATYP na zákazku



19

KOMPONENTY AUTOMATICKÉHO DÁVKOVAČA LEPIDLA PIZZI

pištoľ	Nr 5200080	280,-€	matica upínacia	Nr 5209907	13,-€
support	Nr 5209151	48,-€	kolík	Nr 5209150	6,-€



PRIEBEŽNÝ DÁVKOVAČ



Nr 5200162 924,-€

Zložte si svoj automatický dávkovač podľa Vášho výrobku - atypickú násadu vyrobíme na zákazku.



RYBINA

rybina 300	L 1 m	Nr 302R300	€ 90,30
------------	----------	---------------	------------

fréza rybinová - pozri str.8.6

Zariadením vyhotovíte rybinový, alebo čapový spoj ktorého tvar a rozmery sú závislé od použitej šablóny.

RADII

radlii	Nr 360ROR1	€ 10,75
--------	---------------	------------

Šablóna pre precízne zaobľovanie rohov dielcov (pre rôzne rádiusy) na homej fréze s ložiskom. Sada pozostáva z troch rozličných šablón.

ELLIPSE

ellipse	Nr 3023000	€ 29,00
---------	---------------	------------

Frézovací prípravok umožní vyfrézovať eliptické i kruhové tvary. Vhodné pre použitie všetkých druhov homých fréz.

COMBI

combi	Nr 302650	€ 116,00
-------	--------------	-------------

Šablóna zabezpečí spojenie posformingových pracovných dosiek. Frézuje presne, spoľahlivo! Dokonalý návod. stopková fréza viď str.8.22

LINFIX

linfix 1	L 1 m	Nr 6091000	€ 90,30
linfix 2	2 m	6092000	180,60
linfix 3	3 m	6093000	270,90

linfix SET	fréza	7022062080130A	67,76
	ložisko	7009.6206-2RSR	15,60
	linfix 1	6091000	90,30

Umožňuje výrobu presných šablón, akýchkoľvek tvarov, elasticita prípravku prenesie požadovaný tvar bez nerovnosti, výsledkom čoho je vyfrézovaná šablóna perfektného tvaru.

KBF3M

frézovací stół	Model	Nr	€
podstolový držiak		513FRS001	47,25
homá fréza Makita	RT0702C	513POD001	49,53
		513RT0702C	137,50

Frézovací komplet pozostáva z frézovacieho hliníkového stola s nastavi- teľnými pravítkami a čapovacím uholníkom. Homá fréza Makita, fixovaná v podstolovom držiaku je výškovo plynule nastaviteľná kľučkou z vrchu pre ustavenie nástroja. Komplet odporúčame „vložiť“ do pracovného stola, napojiť na mobilný odsávač a vytvoriť tak frézovacie pracovisko.

VRTACÍ PRÍPRAVOK POWER

power SET	Nr 3012005	€ 165,80
SET obsahuje všetky súčasti vrátane vrtáka 8x30		



príklad vŕtania do plochy príklad vŕtania do hrany príklad vŕtania do plochy

Vŕtací prípravok **POWER** uľahčuje ručné vŕtanie do nábytkových dielcov. **POWER EDGE** sproduktívňuje výrobu kolíkových i komfirmátových rohových spojov. **PÄTKA** uľahčí prácu s rôznymi šírkami dielcov. **POWER FLAT** uľahčuje vŕtanie do plochy dielcov pre podperky, kolíky, NK závesy.

	power edge	3012003	91,30
	pätka	3012001	13,10
	power flat	3012004	81,30
	puzdro	3012002	22,40

vrták ø5x40 HW	231.307.050.11N	13,00
vrták ø6x40 HW	231.307.060.11N	10,60
vrták ø8x40 HW	231.307.080.11N	10,90

Jednotlivé súčasti POWER SETu je možné kúpiť aj samostatne. Ponúkame tiež sortiment tvrdokovových kolíkových vŕtákov do PUZDRA.

POINT

L	Nr	€
600	302MP2P01	23,63

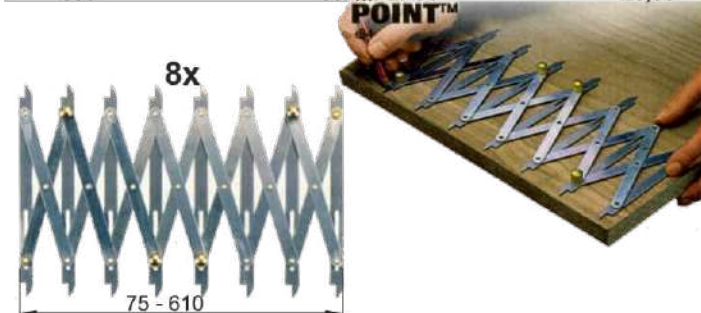

Rovnomerne na 8 častí rozdelí plochu pre vŕtanie, skrutkovanie, kolíkovanie, konštruk. spoje.... Oceníte jednoduchosť a rýchlosť práce s Pointom.

DLÁTO

SET	Nr 360MT979	€ 68,50
náhradné dláta	360144010	32,33
brúsny SET	360MCS01	31,25



SET umožní vŕtanie štvorcových otvorov na stojanovej vrtačke (dlabačke).

KOLÍKOVACÍ PRÍPRAVOK HRANA

L	Nr	€
336	30250411	107,50
400	30258090	112,50
656	302580408	217,42



Kolíkovací prípravok **HRANA** umožní presné horizontálne aj vertikálne vŕtanie otvorov ø 8mm s roztečou 32mm do dielcov s maximálnou hrúbkou 35mm.

KOLÍKOVACÍ PRÍPRAVOK PLOCHA

L	Nr	€
336	30258092	70,00
400	30258091	86,67
656	302580508	140,79



Kolíkovací prípravok **PLOCHA** umožní presné vŕtanie otvorov ø 8mm do plochy dielca (max. hrúbka 35mm) s roztečou 32mm.

ROH

roh	Nr 302ROH	€ 6,00
-----	-----------	--------

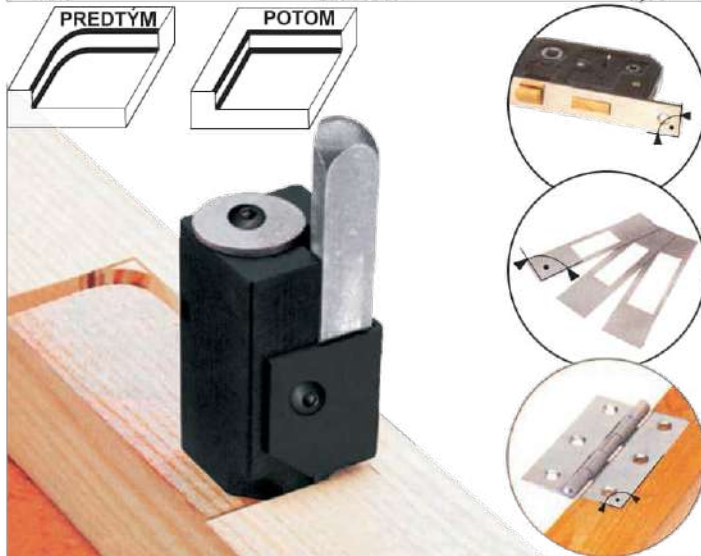

Mechanický rohovač s viackrát ostriteľným HS nožom zabezpečí pravouhlé vyseknutie Vašich dlabov pre osadenie závesov, zámkov, protiplechov ...

PĚTVRETENOVÁ HLAVA NA PODPERKY

TRIMATIC

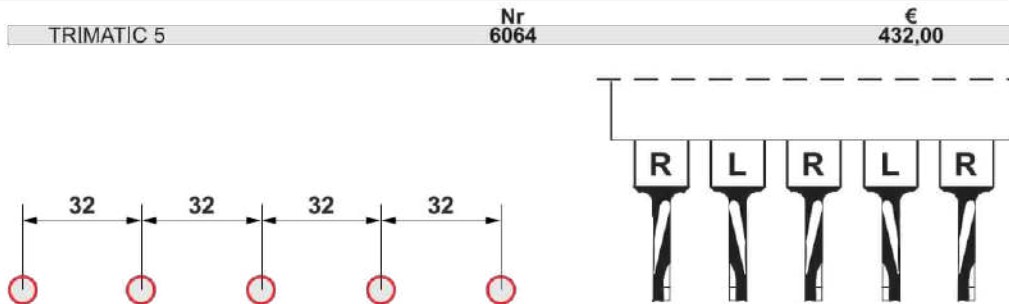
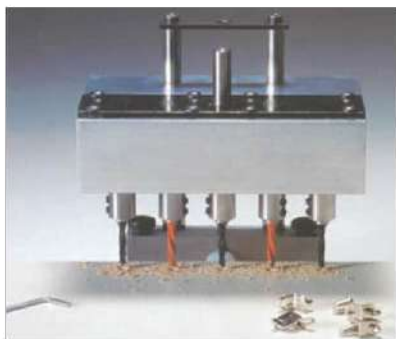

TROJVRETENOVÁ HLAVA NA ZÁVESY

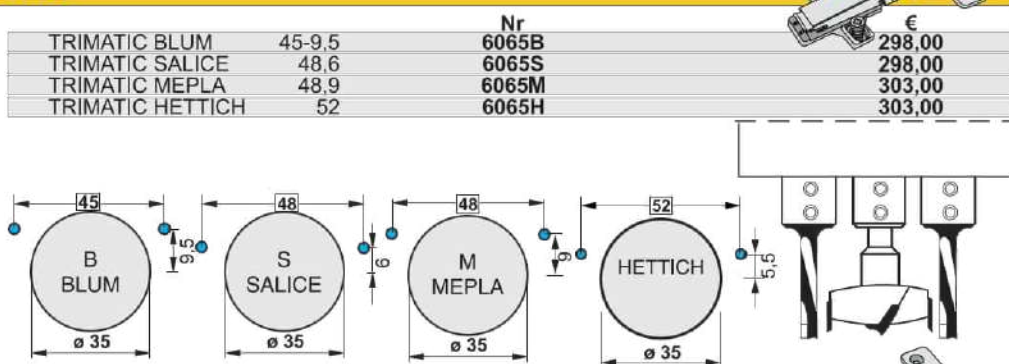

TROJVRETENOVÁ HLAVA DO KOLÍKOVAČKY

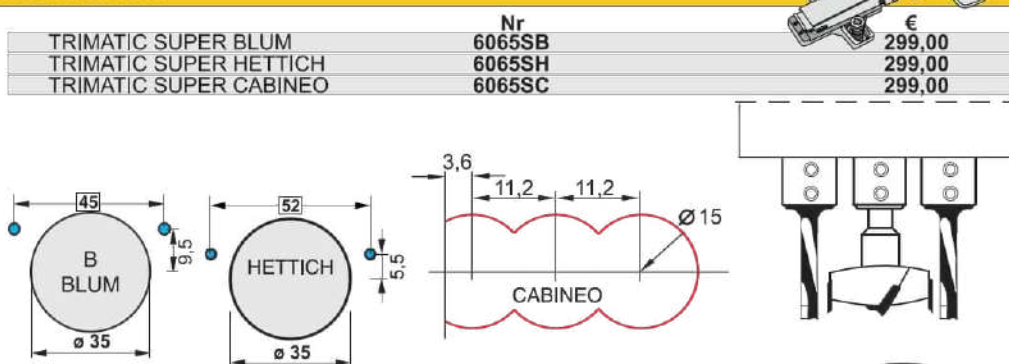

TRIMATIC - TROJVRTÁK NA KLUČKY

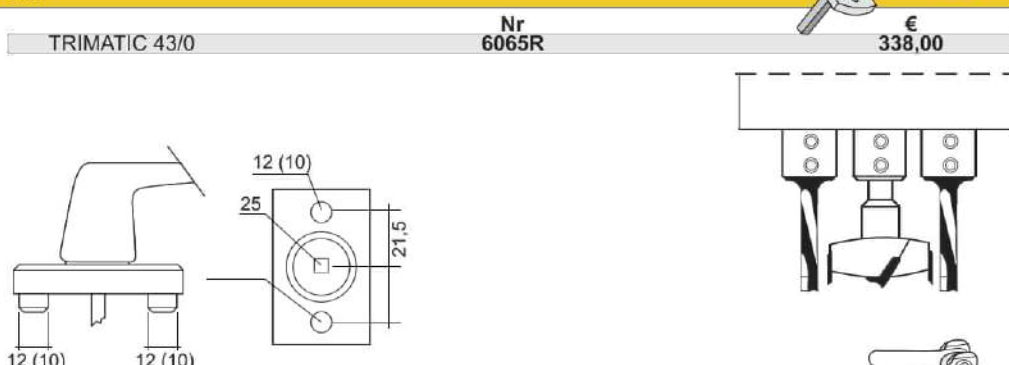

TRIMATIC - DVOJVRTÁK NA OKENNÉ KOVANIE

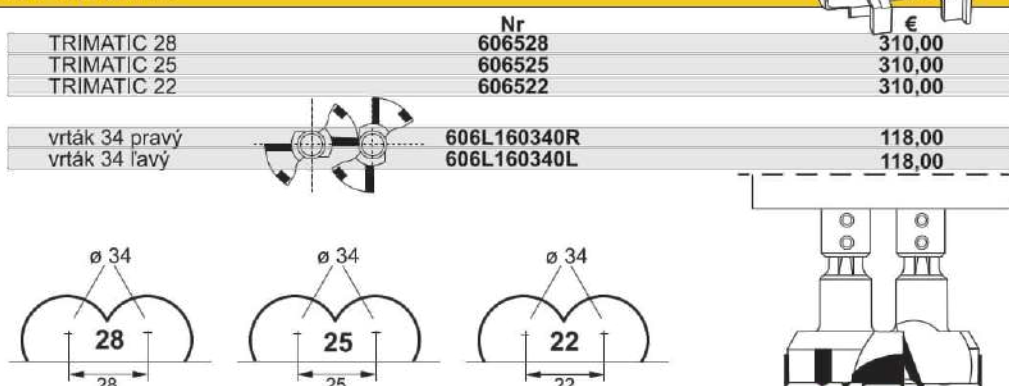

VESTY

OHIO	Nr	veľkosť	€
●	355P13100035000M	(L,XL,XXL)	22,25
●	355P13100034000M	(L,XL,XXL)	22,25



- reflexné doplnky
- zateplená
- 8 vreciek
- zap.zips

AXIS vyhrievaná	Nr	veľkosť	€
mužská	5034932480078M	(L,XL,XXL)	X
ženská	5034933464804S	(L)	

Milwaukee



- odolná vietor-voda
- len 0,94kg
- až 11 hod. ohrevu
- 2 vyhrievané zóny chrbát, ramená
- 4 vrecká

BUNDA

LUX	Nr	veľkosť	€
●	355P1076-48	(50-62)	12,92



- rôzne farby
- odopínacie rukávy
- zapin.zips; 100% bavlna

LUX	Nr	veľkosť	€
●	355P1154-48	(50-62)	17,42



- farby ● ● ● ●
- 100% bavlna
- zapínanie na zips

STRETCH	Nr	veľkosť	€
●	355p101002727048	(50-62)	32,50
●	355p101002771048	(50-62)	31,65



- strečová tkanina
- kryté zapínanie
- reflexné doplnky
- vetranie na chrbte
- 98% bavlna

TRIČKA

DANIEL	Nr	veľkosť	€
●	355P2710250-S	(M~3XL)	4,08

- zelená X
- čierna X
- modrá X
- sivá X



- spevňujúca ramená
- páska, zdvojený trup

STANMORE	Nr	veľkosť	€
●	353030400041800S	(M~3XL)	8,58
●	353030400046900S	(M~3XL)	8,58



- 100% bavlna
- 155 g/m2
- spevnené ramena

CAMBON	Nr	veľkosť	€
●	353030400394100M	(L~XL)	4,58
●	35303040039600M	(L~XL)	4,58



- vhodné na potlač
- 100% bavlna
- 160 g/m2
- 5% elaston

PRACOVNÁ OBUV

Goteborg 01	Nr	veľkosť	€
	3593285-36	(37~48)	18,33



- bez. oceľovej špice
- celokožená obuv
- protišmyková

Tokio Orange	Nr	veľkosť	€
	3592135-36	(37~48)	30,75



- protišmyková
- hovädzinová useň
- bez oceľovej špice

Sport Alfa 01	Nr	veľkosť	€
	359270005-36	(37~48)	33,25



- hovädzinová useň
- vysokopriedušná podšívka

Lisabon S1	Nr	veľkosť	€
	3592660-41	(42~46)	31,58



- protišmyková
- bezpečnostná
- brúsená hovädzia koža

STOCKHOLM

zimná	Nr	veľkosť	€
	3593285-41	(42~46)	18,33



- vnútorná plyš
- odolnosť zvršku proti vode

FALUN	Nr	veľkosť	€
zimná	3593290-02W/41	(42~46)	20,83



- protišmyková
- vnútro plyš
- hovädzinová useň

SAN MARINO	Nr	veľkosť	€
zimná	3593171-36	(37~48)	33,25



- koža
- vnútro plyš
- extrémne pohodlná

NOHAVICE

LUX	Nr	veľkosť	€
●	355P1080-48	(50-62)	13,25
●	355P11551-48	(50-62)	13,25



- rôzne farby
- zdvojené kolenná
- pútka na opasok

ROBIN	Nr	veľkosť	€
●	355P1155-48	(50-62)	X
●	355P1255-48	(50-62)	



- rôzne farby
- s náprsenkou
- 100% bavlna
- 280g/m²

ORION	Nr	veľkosť	€
●	355P1160-CC 48	(50-62)	17,50
●	355P1160-HC 48	(50-62)	17,50



- vzadu do gumy
- Multifunkčné vrecká

TOMAS	Nr	veľkosť	€
●	355P1159-48	(50-62)	7,92



- praktické
- do gumy
- pútka na opasok

CRAMBLE	Nr	veľkosť	€
●	3530310001512000	(50-62)	24,17



- viacero vreciek
- moderný strih.

THERMO

REWARD	Nr	veľkosť	€
nátenník	355p1720002808/M	(L~2XL)	17,42
nohavice	355p174000280M	(L~2XL)	17,42



- funkčné termo
- hrejivý materiál
- 92% polyester, 8% elastan

PONOŽKY termo	Nr	veľkosť	€
Akcite	355.016		2,42



- 80% bavlna, 5% elastan
- 15% polyamid,

Sock thermo	Nr	veľkosť	€
	355.018		2,42



- špeciálna zdravotná guma
- 80% bavlna, 5% elastan
- 15% polyamid,

SIRIUS

SIRIUS	Nr	€
●	355p1820059703	3,25
●	355p1820059702	3,25



- 100 % akryl
- zimná

ŠILTOVKA	Nr	€
FESTOOL	510497899	11,66



- pevný zahnutý štít
- prestaviteľné veľkosti

ŠILTOVKA reflex	Nr	€
●	355P229	3,75
●	355p22290	3,75



- vzadu sieťovaná
- zapínanie na suchý zips

RUKAVICE

MULTI FLEX	Nr	Veľkosť	€
č.8 ; 9; 10	353709276,	7, 8	3,25

- jemný úplet z nylónu
- mikropenový povlak
- veľmi dobrý dotyk



PELIKÁN	Nr	Veľkosť	€
č.8, 9, 10	3530101006899108,	09, 10	2,67

- ovčia líčková koža
- manžeta na suchý zips



PALAWAN	Nr	Veľkosť	€
č.8, 9, 10	35301080029908,	09, 10	1,84

- nylon / latex
- mechanické povrstvené



ODOLNÉ	Nr	Veľkosť	€
č.M,L,XL,XXL	5034932471416,	17~19	4,42

- proti porezu úrovne 1
- aj na dotykovú obrazovku



BEZ PRSTOV	Nr	Veľkosť	€
č.M,L,XL,XXL	50348229741,	42~44	18,50

- zosilnené švy
- maximalizujú obratnosť



DEMOLAČNÉ	Nr	Veľkosť	€
č.M,L,XL,XXL	5034932478127,	28~30	26,11

- odolné proti prerezaniu
- ochrana proti nárazom



KOŽENÉ	Nr	Veľkosť	€
č.M,L,XL,XXL	5034932471912,	13~15	27,93

- výkonné s odolnou dlaňou
- priedušné ľahké



JESENNÉ	Nr	Veľkosť	€
č.M,L,XL,XXL	5034932471343,	44~46	8,17

- proti porezu úrovne 1
- 3 stupne ochrany



ZIMNÉ	Nr	Veľkosť	€
č.M,L,XL,XXL	5034932471347~350		12,51

- povrstvenie nitrilom zaisťuje bezpečné uchopenie
- dodatočná izolovaná vrstva



CHRÁNIČ SLUCHU

3M X-Series	Nr	€
PELTOR	3537000103993	37,42

- úroveň útlmu 27 dB
- Nízka hmotnosť (184 g)



Optime 3M III	Nr	€
čierny	3530723770	26,67

- úroveň útlmu 35 dB
- technológia dvojitého púzdra



LA 3001 mix	Nr	€
čierny	353451244	10,33

- úroveň útlmu 23 dB
- aj pre lesnícky komplet



CHRÁNIČE SLUCHU

EAR CLASSIC	Nr	€
PVC pena	3534110	0,25

- úroveň útlmu 28 dB
- jednoduché a pohodlné použitie, umývateľné



EAR SOFT	Nr	€
Neon	3534112	0,21

- úroveň útlmu 36 dB
- dokonalé utesnenie
- optimálne pohodlie



ZÁTKOVÝ CHRÁNIČ	Nr	€
Comfort	353451244	10,33

- úroveň útlmu 25 dB
- pre celodenné pohodlie



RESPIRÁTOR - MASKY

Polomaska Spiro	Nr	€
s ventilom 731	355p7232	1,33

- SPIRO triedy P1 s výdychovým ventilčekom
- FFP1



Polomaska 3M	Nr	€
6200 M	353M6200	20,00
6300 L	353L6300	20,00

- bajonetový systém pre 2 filtre pre rýchlu výmenu
- nenáročná údržba



FILTRE pre Masku	Nr	€
kaučuk A1	35360511	11,42
lepidlá, laky A2	3536055	13,92
živice, plyny ABE1	3536057	13,67
čpavok ABEK1	3536059	13,26

- bajonetové filtre
- priemyselná aplikácia



BEZPEČNOSTNÝ POSTROJ

POSTROJ BASIC	Nr	€
komplet	353FLXK02	22,92



- pre práce v stavebníctve
- zadný a predný kotviaci prvok, nastaviteľné ramenné



ZACHYTÁVAČ	Nr	€
stopcord	353FLPACK	73,30



- zachytávač pádu pre prácu na šikmých strechách



OKULIARE, ŠTÍT

OKULIARE BASIC	Nr	€
triedy F	3535191	2,42

- panoramatický zorník
- číre polykarbonátové sklo
- aj cez dioptrické okuliare



OKULIARE PROFI	Nr	€
číre sklo	5034932471881	8,61
tónované sklo	5034932471882	8,61

- so šošovkami Anti-Fog
- proti poškrabaniu



ŠTÍT	model	Nr	€
200x290 mm	SP28	35328	16,00
330x290 mm	SP29	35329	17,50

- PMMA (plexisklo), hrúbka 2 mm
- ochrana oči a tváre



BEZPEČNOSTNÉ TABUĽKY



VSTUP ZAKÁZANÝ



POZOR, elektrické zariadenie!



Ponúkame široký výber bezpečnostných tabuliek. Žiadajte samostatný katalógový list.

NOHA ODVAĽOVACIA

	výškovo nastaviteľná	zaťaženie	Nr	€
guličkový	630-1000 mm	50kg	44861023	55,00
valcový		60kg	4486119973	37,00



Multifunkčný stojan pre predĺženie pracovného stola stroja.

Valcový stojan pre ľahšiu manipuláciu pri obrábaní.

KOZY MONTÁŽNE - KOV

	Nr	€
1 pár	333059	37,50



KOZY MONTÁŽNE - PLAST

	Nr	€
1 pár	305170355	37,92
	30570713	60,42



Ľahko transportovateľné, pevné oceleové "kozy" sú zvlášť vhodné pre montážnické práce. SET - 2ks kôz.

Pevná a robustná konštrukcia z polypropylénu, nízka hmotnosť, ľahké prenášanie

TRANSPORTÉR TS

	nosnosť	Nr	€
TS 850	max. 100kg	4485501000	116,30
TS 1500	max. 200kg	4485525000	253,30



Skladací vozík s teleskopickou rukoväťou, použiteľný aj na schodište.

RUDLA TK 200

	zaťaženie	Nr	€
kolesá 260mm	200kg	333TK200	59,88



Oceleová rudla s nosnosťou 200kg. S nafukovacími kolesami priemeru 260mm.

AKUMULÁTOROVÁ PRÍSAVKA GRABO PRO

	balenie	nosnosť	Nr	€
grabo v taške		170kg	50101	290,00
grabo v kufrí		170kg	50102	399,00



Prísavka je vybavená robustnou vákuovou pumpou. Použiteľné pre manipuláciu rôznych druhov materiálov.

POPRAH SŤAHOVACÍ

Nr	€
4485582	53,21



Systém ramienok na sťahovanie, každodenný pomocník na prepravu nákladov bez únavy chrbta.

MULTIFUNKČNÝ STÔL

Festool MFT/3	Nr	€
komplet	510495315	716,67
bez príslušenstva	510500608	629,33



1 157 x 773 mm

Vodiaca lišta alebo kombinovaný uhlomer - všetko sa bezpečne upevní.

Vodiaca svorka	Nr	€
Festool FS-HZ 160	510491594A	49,92
Svorka 160	360A16060	26,58

- pre vodiace lišty a perforované stoly



Páková svorka	Nr	€
Festool MFT-HZ 80	510577132	36,67



Skrutkovacia zvierka	Nr	€
Festool	510489570	44,08
Makita - set 2ks	5131943855	23,33



FESTOOL

Upínák do stola	Nr	€
excenter drevený	360A5000	9,50



Upínacie prvky	Nr	€
MFT-SP; set 2ks	510488030	99,17



Doraz hliníkový D20	Nr	€
pre performované stoly	360A2004	3,25



PRACOVNÝ STÔL MASTER

	Nr	€
master 200	4486177	79,17
master 600	4486182	114,75



Robustný, univerzálny upínací a pracovný stôl je súčasťou základného vybavenia dielne.

MULTI STÔL

	Nr	€
PROTECO 4v1	50643SPM04	110,83



Použitie ako výškovo nastaviteľný stôl alebo plošina. Integrované kolieska pre možnosť pojazdu.

SCHODÍKY PRACOVNÉ

stupne	výška	Nr	€
3	65cm	5061066203OB	41,25
4	85cm	5061066204OB	56,67
5	105cm	5061066205OB	60,42
6	130cm	5061066206OB	70,75



Robustné, nárazuvzdorné, protišmykové s kovovým kĺbom v hliníkovom vyhotovení s max. nosnosťou 150kg.

PRACOVNÝ KOMPLET

	Nr	€
horná skrinka	31640954	80,83



perforovaná stena	31640956	24,17
-------------------	----------	-------

stôl 1200x850x600	31640928	245,83
-------------------	----------	--------

SKRIŇA POLICOVÁ - hlboká

	Nr	€
kovová typ BG	316200410	339,08



1920x780x580 mm

Zváraná konštrukcia z kvalitného oceľového plechu 1,0–1,5 mm. Nosnosť police 50 kg.

SKRIŇA NA NÁRADIE

	Nr	€
kovová typ B	31640940	207,50



1920x780x380 mm

Vyrobená z kvalitného oceľového plechu s hrúbkou 0,7-1,5 mm. Nosnosť police 50 kg.

ORGANIZÉRY

BOX	d x š x v	Nr	€
●	54x54x63	4501238865	0,75
●	108x54x63	4501238866	1,12
●	108x108x63	4501238867	1,54
●	162x108x63	4501238868	1,75
●	216x108x63	4501238869	1,91



Vyskladajte si svoj úložný priestor.

ECOBX	Nr	€
small	35135203 ..	1,00
medium	35135200 ..	2,50
large	35135208 ..	6,25

● ● ● ● ●

165x110x75 mm
240x155x125 mm
350x220x165 mm



Stohovateľné robustné zásobnice.

KUFRE

MINI SYSTEMAINER	d x š x v	Nr	€
1TL	265x171x75	510499622	17,92
3TL	265x171x142	510202544	21,83



Vyskladajte si svoj úložný priestor.

SYSTEMAINER SYS3	model/výška	Nr	€
	M 137	510204841	55,83
	M 187	510204842	59,58
	M 237	510204843	57,50
	M 337	510204844	57,50
	M 437	510204845	71,67



š396 x h296 mm

Dva priehľadné organizéry vo veku.

PACKOUT tenký	Nr	€
malý	5034932471065	31,50
veľký	5034932471064	43,78



Obzvlášť odolný voči nárazom, prehľadný, vhodný pre montážnikov.

PACKOUT veľký	Nr	€
kompakt	5034932464083	32,58
veľký	5034932464082	46,44



MAKPAC systainer	typ	výška	Nr	€
	typ 1	105	513821549-5	21,25
	typ 2	157	5138215500	29,58
	typ 3	210	513821551-8	30,17
	typ 4	315	513821552-6	40,75



š396 x h296 mm

Obzvlášť odolný voči nárazom, prehľadný, vhodný pre montážnikov.

BOX	typ	d x š x v	Nr	€
	16"	405x210x183	316192065	15,75
	24"	610x270x280	316192067	22,08



MARS skrinka	d x š x v	Nr	€
	306x190x145	3336736M	18,75
	306x460x145	3336741M	40,33
	306x442x145	3336703M	37,92



Osvedčený metal rám so zásuvkami.

MULTI cabinet	d x š x v	Nr	€
	365x160x225	316193980	15,92



Lahké plastové vyhotovenie.

Vodotesný	d x š x v	Nr	€
	446x356x74	316197517	28,00
	446x356x116	316197518	28,38



Chráni obsah pred vysypaním.

FATMAX 18"	d x š x v	Nr	€
	394x220x162	316171219	42,50



Kovové koľajnice. Zvlášť odolný.

BRAŠNE

FatMax Multi	d x š x v	Nr	€
	430x280x300	316173607	61,25



Spevnené dno, úložné vrecká, rýchle zapínanie, dobrý prístup k náradu.

FatMax Bag	d x š x v	Nr	€
	500x300x290	316171180	50,83



PREPRAVKY

PACKOUT pojazdný	d x š x v (cm)	Nr	€
	41x56x94	5034932464244	412,-



Najuniverzálnejší, uzamykateľný.

ROLLING pojazdný	d x š x v	Nr	€
	500x300x290	316179206	124,17



Integrovaný samostatný box.

TAŠKA SBB na pílové kotúče	d x š x v	Nr	€
	320x315x70	510577219	37,01



Pre pílové kotúče do 260mm, 5ks.

PUZDRO na mobil	d x š x v	Nr	€
	90x40x165	51305583	11,08



Praktický držiak na smartfón do 6,1"

KAPSA	d x š x v	Nr	€
	185x85x205	51315285	15,67



Pre kladivo, kliešte a inú výstroj.

MULTI cabinet	d x š x v	Nr	€
	180x105x185	51305197	15,83



Pre sypané kĺnce skrutky a náradie.

VOZÍK PRE SYSTEMAINERY	Nr	€
125kg nos.	513TR0000001	164,-



Kompatibilné pre všetky systemainery.

FATMAX vodeoodolný	Nr	€
	316FMST1-75761-1	64,08



Vodeoodolný box s kolieskami.

PÁSKOVAČE

	Nr	€
páskovač 10"	3532900	110,00
páskovač 13"	353014A	115,00
páskovač 16"	3539083	113,33



Mechanický ručný páskovač určený k sponkovému páskovaniu PP pásy šírky 12 mm.

PÁSKY, SPONKY

	Nr	€
páska PP čierna 10	3538060	16,66
páska PP čierna 12	3530136	39,16
páska PP čierna 16	3538059	40,00



	balenie	Nr	€
spony „10“	200ks	3539129-200	4,17
spony „10“	1ks	3539129	0,025
spony „13“	200ks	3530030-200	10,00
spony „13“	1ks	3530030	0,042
spony „16“	200ks	3532899-200	8,33
spony „16“	1ks	3532899	0,37



STRECH FÓLIA

farba	Nr	€
biela	3530112	5,08
čierna	3530707	5,50

pri odbere 6ks/1kartón
cena za kus 4,25



odvíjač strechovej fólie	3533000	5,25
--------------------------	---------	------



držiak strechovej fólie	3532874	5,67
-------------------------	---------	------

PRÍEMYSELNÉ POSÚVAČE



	AV 8/6	AV 4/4	VAR 4	AV 4/3	VAR 3	AV 3
počet kolies	6	4	4	4	3	3
počet rýchlostí	8	4	plynule	4	plynule	4
st. rýchlostí (m/min.)	2-4-5-6-11-13-16-33	4-8-11-22	4 ~ 22	4-8-11-22	4 ~ 22	3-4-7-8-15
priemer kolies (mm)	120	120	120	120	120	80
šírka kolies (mm)	60	60	60	60	63	28
výkon (kW)	0,7	0,7	0,7	0,7	0,7	0,18
hmotnosť (kg)	78	66	66	63	63	32
Nr	5147100	5147110	5147120	5147130	5147140	5147150
€	1 766,-	965,-	1 427,-	822,-	1 323,-	570,-

maggi	B	Nr	€
	80 mm	5191110110	30,60

maggi	B	Nr	€
	25 mm	5191110176	54,10
	20 mm	5191110181	54,10

maggi	B	Nr	€
	40 mm	5191110034	51,10
	50 mm	5191110039	34,30
	60 mm	5191110041	36,30

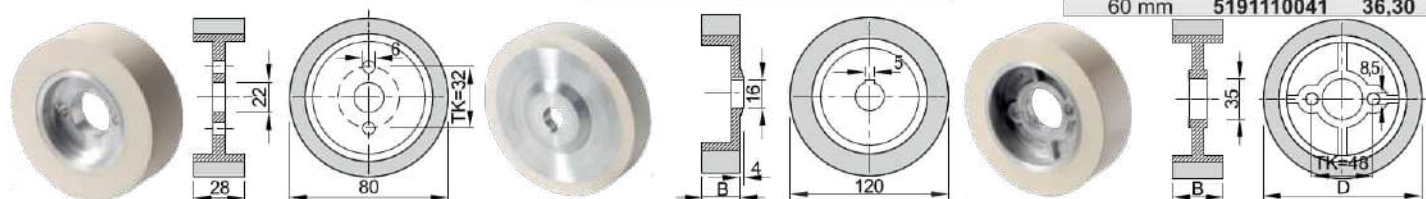

POGUMOVANÉ PODÁVACIE KOLESÁ

scm	B	Nr	€
	50 mm	5191110076	88,40
	30 mm	5191110067	83,90
	20 mm	5191110056	82,10

scm	B	Nr	€
	50 mm	5191110036	83,90
	20 mm	5191110026	79,40

scm	B	Nr	€
	60 mm	5191110002	87,80
	30 mm	5191110001	76,00

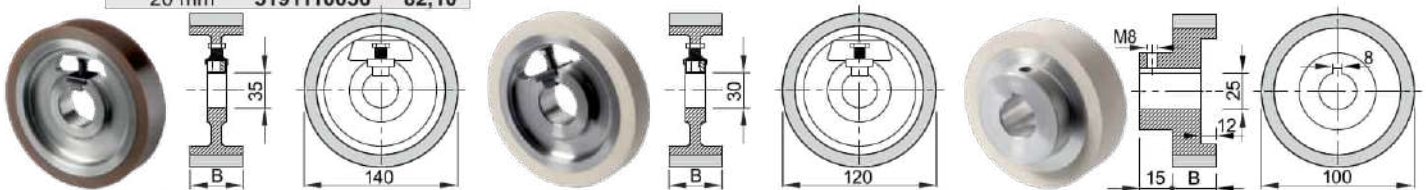

WEINIG	B	Nr	€
	30 mm	5191110066	93,60

WEINIG	B	Nr	€
	25 mm	5191110063	83,20
	20 mm	5191110054	83,20
	15 mm	5191110051	83,20

WEINIG	B	Nr	€
	50 mm	5191110144	82,10

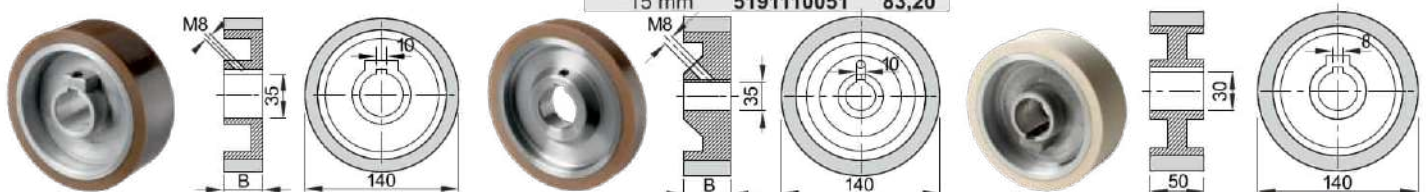

WOOD-B
priateľ dreva
12.30
výber 18

OCĚLOVÉ PODÁVACIE KOLESÁ PRE ŠTVORSTRANNÉ FRÉZOVAČKY

PROFIL OZUBENIA



PROFIL OZUBENIA

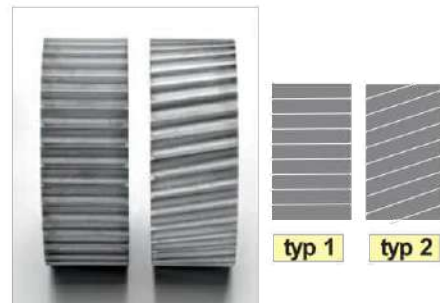

Pri objednaní podávacieho kolesa požadovaného modelu si vyberte **profil** a **typ** ozubenia, ktoré Vám obratom naceríme. Nad rámec uvedenej ponuky disponujeme širokým sortimentom ďalších modelov podávacích kolies, prípadne zabezpečujeme ich zákazkovú výrobu.

WEINIG	B	Nr	€	WEINIG	B	Nr	€	WEINIG	B	Nr	€
	50 mm	519140-50-35 Z	dopyt		50 mm	519140-50-35 Z Weinig	dopyt		30 mm	519140-30-35 Z	dopyt
									25 mm	519140-25-35 Z	dopyt
	B	Nr	€		B	Nr	€		B	Nr	€
	20 mm	519140-20-35 Z	dopyt		50 mm	519140-30-30 Z	dopyt		50 mm	519140-50-30 Z	dopyt
	15 mm	519140-15-35 Z			30 mm	519140-50-30 Z			30 mm	519140-30-30 Z	
	10 mm	519140-10-35 Z			20 mm	519140-20-30 Z			30 mm	519140-30-30 Z	
	B	Nr	€		B	Nr	€		B	Nr	€
	25 mm	519140-25-30 3V Z	dopyt		50 mm	519170-50-35 Z	dopyt		20 mm	519170-20-35 Z	dopyt
	20 mm	519140-20-30 3V Z			30 mm	519170-30-35 Z			15 mm	519170-15-35 Z	
	15 mm	519140-15-30 3V Z			25 mm	519170-25-35 Z					
	B	Nr	€		B	Nr	€		B	Nr	€
	50 mm	519170-50-35 3V Z	dopyt		25 mm	519170-25-35 3V Z	dopyt		60 mm	519140-60-110-10 Z	dopyt
	30 mm	519170-30-35 3V Z			20 mm	519170-20-35 3V Z					
	15 mm	519170-15-35 3V Z			15 mm	519170-15-35 3V Z					
	B	Nr	€		B	Nr	€		B	Nr	€
	50 mm	519140-50-35 Z	dopyt		50 mm	519120-50-30 Z	dopyt		50 mm	519120-50-30 Z	dopyt
	30 mm	519140-30-35 Z			20 mm	519120-20-30 Z					
	25 mm	519140-25-35 Z									
	B	Nr	€		B	Nr	€		B	Nr	€
	20 mm	519140-20-35 3V Z	dopyt		50 mm	519140-50-30 4V Z	dopyt		48 mm	519140-48-35 6V Z	dopyt
									23 mm	519140-23-35 6V Z	dopyt
	B	Nr	€		B	Nr	€		B	Nr	€
	20 mm	519140-20-35 3V Z	dopyt		50 mm	519140-50-30 4V Z	dopyt		48 mm	519140-48-35 6V Z	dopyt
									23 mm	519140-23-35 6V Z	dopyt
	B	Nr	€		B	Nr	€		B	Nr	€
	20 mm	519140-20-35 3V Z	dopyt		50 mm	519140-50-30 4V Z	dopyt		48 mm	519140-48-35 6V Z	dopyt
									23 mm	519140-23-35 6V Z	dopyt

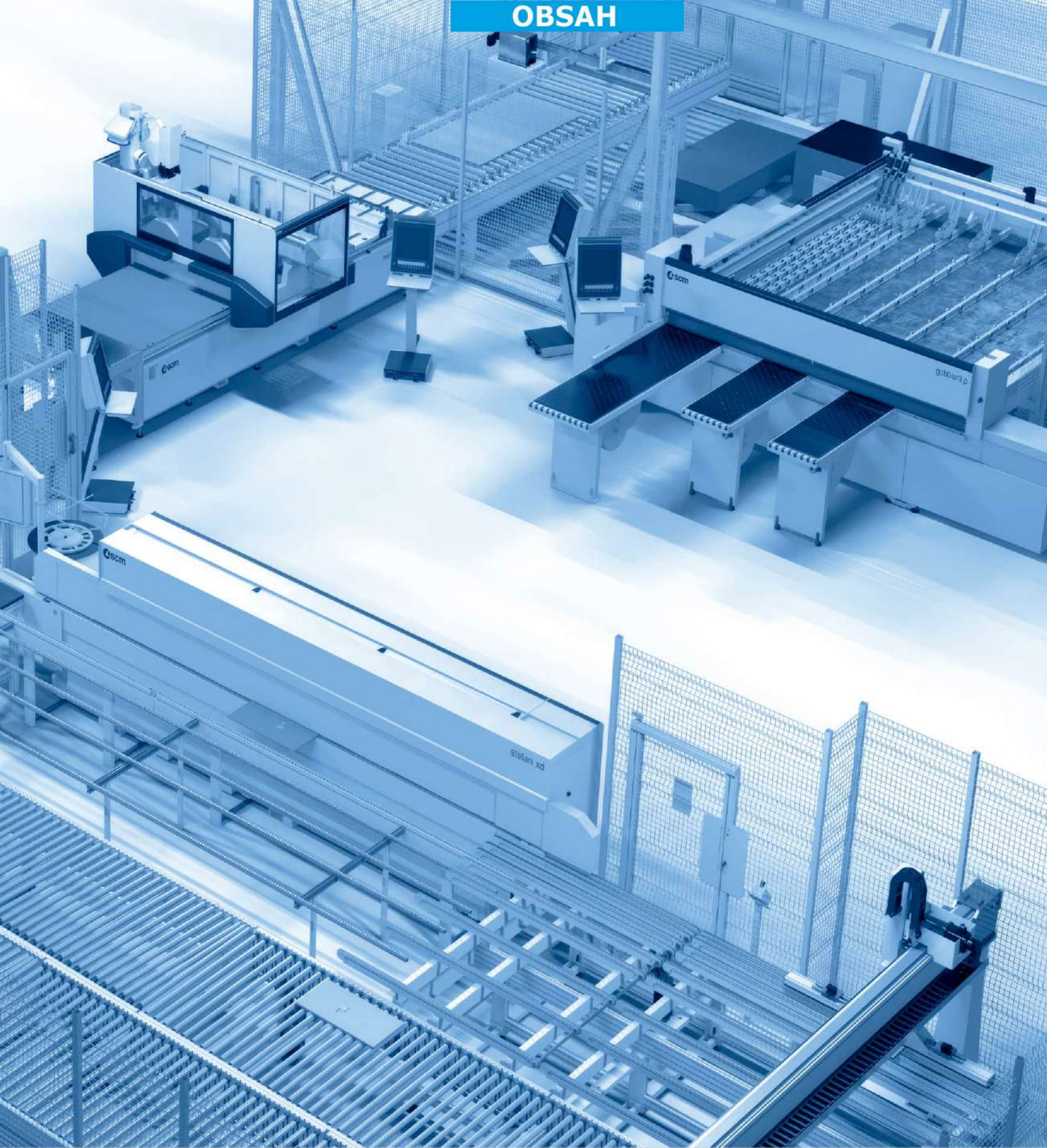

 **scm**
minimax
scm tecmatic
routech

 **celaschi**
dmc
superfici
sergiani

 **gabbiani**
morbidelli
mahros
stefani

 **Cms**
wood technology

STROJE



eshop.woodb.sk



PÍLY

M3



GABBIANI PT 75



CLASS PX 350i



FLEXSTORE

TRADIČNÉ
STROJE

NOVA F520



NOVA S 630



NOVA TF 110 TL



scm



online katalóg

4-STRANNÉ
FRÉZOVAČKY

PROFISSET 40 EP



PROFISSET EP 60



SUPERSET NT

... žiadajte tlačný
KATALÓG+CENNÍK!OBRÁBACIE
CENTRÁ

AUTHOR M 100 F

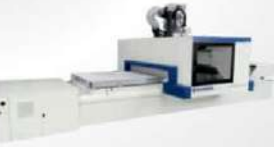

AUTHOR 220 5-osí



ACCORD 25 FX M 3-osí



MORBIDELLI N100



VŔTAČKY

STARTECH CN V



CX 100



CX 210



CX 220

EGALIZAČNÉ
BRÚSKY

DMC SD 10



DMC SD 60 RCS



DMC MB 90



DMC EUROSYSTEM



OLEPOVAČKY

OLIMPIC K 360 T-ER1



OLIMPIC K560 T-ER2



STEFANI KD



STEFANI MD



LINKY

DOGMA



MVC



MAGNUM



OIKOS





FORMÁTOVACIE PÍLY

SC 2C



SC 4E



SI 400ES



SI X



SPODNÉ FRÉZY

T 45C



T 55 ES



TW 45C



TW 55 ES



ZROVNÁVAČKY-HRÚBKOVACKY

FS 30C



FS 41C



FS 41ES



FS 52ES



OLEPOVAČKY

ME 25



ME 28 T



ME 35 T



ME 40 TR



KOLÍKOVACKY-HORNÉ FRÉZY

ADVANCE AD 21



STARTECH 27



ROUTER 800



T 124



PÁSOVÉ PÍLY

S 440P



S 600P



S 45N



CUT 350



PÁSOVÉ BRÚSKY

UNILEV 150



DG 60



LS



KOMBINOVANÉ STROJE

C 26G



CU 300C



LAB 300P



CU 410ES





ITALPRESSE
OSAMA

Italpresse XL 6



Italpresse Lockform



Osama S4R



Osama GT90



casati

Casati Z 1000



Casati GOH



Casati TIO 600



Casati FILA



STROMAB
MACCHINE PER LA LAVORAZIONE DEL LEGNO
centauro

Stromab Matrix 4



Stromab Autoblox



Centaurio CO600



Centaurio T-Max



Hundegger

Hundegger SC3



Hundegger K2-i



Hundegger SPDM



Hundegger Montagepult



LÖWER

Lower MultiMaster



Lower MultiMaster



Lower DoubleMaster



Lower WindowMaster



BLUE ELEPHANT

ELE 1325-3



ELE 400



5 Axis CNC Router



ELE 2023 ATC



finiture

Plants for Windows



Plants for Doors



Dry Box



Pro Flow Evo



SARMAX

Cheyenne SP24



Apache 7



Kompact



Fibertech M



OBSAH OBCHOD - KONTAKT



WOOD-B s.r.o.

Považská 30, 940 02
Nové Zámky, Slovensko



+421/35/6 922 000
+421/903 100 173



woodb@woodb.sk
eshop@woodb.sk



woodb.sk



eshop.woodb.sk



Obrázky v katalógu sú ilustračné.



... aktuálne ceny vždy na eshope
... objednáte - ešte **dnes** odošleme,
aby ste **zajtra** mohli pracovať.
... platí pre celé Slovensko a Česko

Vyhradujeme si právo na zmenu cien v katalógu. Všetky ceny sú uvedené bez DPH.

Drevoobrábacie stroje - predaj, servis

REGIÓN: JUH, SEVER

Martin Peško

+421 903 691 610
pesko@woodb.sk

REGIÓN: ZÁPAD

Bc. Ivan Novák

+421 902 290 920
novak@woodb.sk

MANAGER WOOD-B

Ing. Erik Komáromy

+421 903 690 480
komaromy@woodb.sk

SERVISNÉ ODDELENIE

Ing. Pajchortová D.

+421 911 020 003
servis@woodb.sk



Nástroje - predaj, servis, výroba

REGIÓN: JUH

Milan Vaško

+421 903 437 645
vasko@woodb.sk

REGIÓN: ZÁPAD

Miroslav Bihari

+421 911 722 063
bihari@woodb.sk

REGIÓN: SEVER

Marek Andel

+421 911 825 011
andel@woodb.sk



MANAGER WOOD-B

Ing. Boris Bršel

+421 903 659 109
brselb@woodb.sk

PILIARSTVO

Juraj Vašek

+421 911 424 078
vasek@woodb.sk

REGIÓN: ČESKÁ REPUBLIKA

Petr Panenka

+420 777 747 634
panenka@woodb.sk



OSTRENIE

Silvia Halandová

+421 /35/ 6 922 000

woodb@woodb.sk

Maloobchod

MANAGER MALOOBCHOD

Ing. Boris Bršel

+421 904 098 575
brselboris@woodb.sk

Oddelenie: NÁSTROJE

Marián Bolya

+421 /35/ 6 922 023
nastroje@woodb.sk

Oddelenie: KOVANIE

Roman Kozlík

+421 /35/ 6 922 011
kozlik@woodb.sk

Oddelenie: NÁRADIE

Jaroslav Makai

+421 /35/ 6 922 028
elektro@woodb.sk

Oddelenie: MATERIÁLY

Dušan Kosec

+421 /35/ 6 922 027
material@woodb.sk

Oddelenie: KOVANIE, POMOCKY

Eva Zemaníková

+421 /35/ 6 922 034
kovanie@woodb.sk

... nakupujte výhodnejšie



za nami stoja silné značky





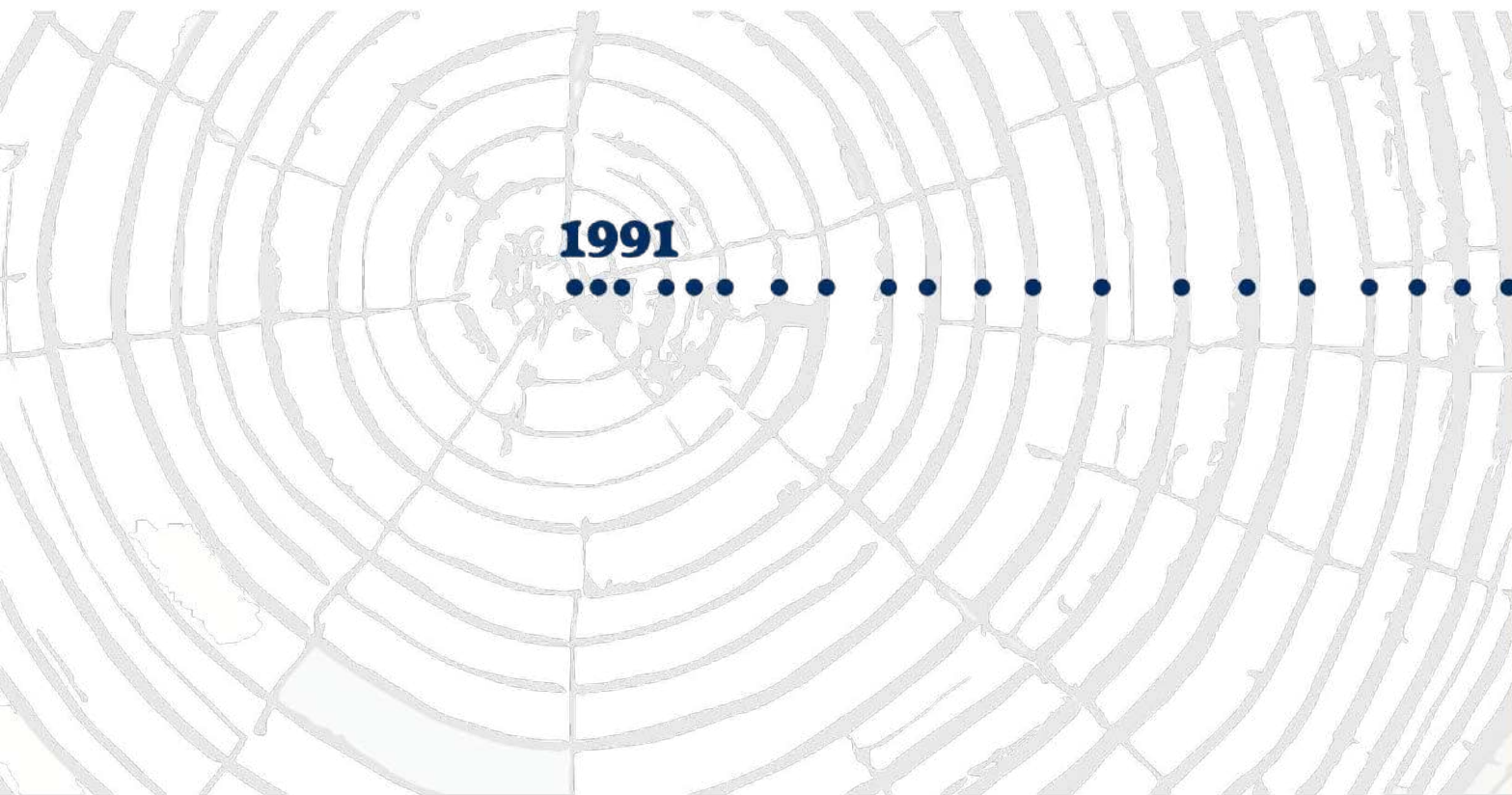

woodb.sk

 woodb.sk

 eshop.woodb.sk